



A Guide to Decisionmaking

Technology Options for Urban Sanitation in India



A Guide to Decisionmaking

Technology Options for Urban Sanitation in India



September 2008

Contents

Foreword	vii
Message	ix
Introduction	xi
Acronyms and Abbreviations	xiii
Part A	
Setting the Scene	1
Defining Sanitation	3
Urban Sanitation: What are the Challenges?	3
Technology and Program Design	6
Legislation and Standards for Urban Sanitation	11
Part B	
Introduction to Sanitation Technologies	13
Understanding Sanitation Technologies	15
On-Site Systems	18
Off-Site and Hybrid Systems	21
Treatment of Wastewater and Fecal Sludge	22
Reuse of Treated Wastewater and Sludge	25
Summary of Common Technology Options	26
Part C	
Framework for Decisionmaking	31
Overview of the Decisionmaking Process	33
Stage 1: Outline Survey of Settlements and Services	34
Map Existing Land Use and Settlement Types	34
Gather Information about Existing Sanitation Infrastructure and Services	35
Outcome from Stage 1	37

Stage 2: Needs Assessment and Consultation	38
Community Consultation	38
Outcome from Stage 2	40
Stage 3: Identifying Appropriate Technologies	42
Overview	42
On-Site or Off-Site Disposal?	43
Options for Removal and Transport of Fecal Sludge and Septage	49
Sewerage Options	50
Treatment Options	51
Output from Stage 3	55
Stage 4: Developing Costed Options	56
Assessing the Costs	56
Service Delivery and Maintenance Options	58
Output from Stage 4	60
Stage 5: Reaching Consensus on Preferred Options	61
Facilitating the Process	61
Outcome from Stage 5	62
Part D	
Toolkit	63
Appendix A: Participatory Communication Tools	65
Appendix B: Costing Technology Options	69
Appendix C: Institutional Options for Operation and Maintenance	72
Appendix D: Technology Data Sheets	79
Glossary	118
References and Sources of Additional Information	122

Tables

1	Possible Management Options for Urban Sanitation	11
2	Sanitary Pit Emptying Options	20
3	Types and Sources of Domestic Wastewater and Fecal Sludge	22
4	Types of Treatment Processes	23
5	Sanitation Options for Different Residential Settlement Types	27
6	Settlement Characteristics and their Influence on Sanitation Technologies	35
7	Relevant Information about Existing Services	36
8	Participatory Tools to Assist in Initial Investigations	37
9	Participatory Tools Useful for Needs Assessment	39
10	Level of Sanitation Service Provision	41
11	Approximate Water Consumption Figures for Different Levels of Water Supply Service	43
12	Relationship between Water Use and Disposal Option	44
13	Types of Toilet and Estimates of Water Consumption/Wastewater Production	44
14	Theoretical Infiltration Capacity for Different Soil Types	45
15	Types of Fecal Sludge and Implications on Cartage	49
16	Alternative Sewerage Options for Residential Areas	51
17	Impact of Wastewater Characteristics on the Choice of Wastewater Treatment Process	53
18	Options for Wastewater Treatment According to the Level of Centralization	54
19	Operation and Maintenance Tasks	58
20	Comparative Life Cycle Costs of Technology Options	60
21	Management Options	60
22	Institutional Options for the Construction, Delivery, and Maintenance of Urban Sanitation Services	75

Figures

1	Basic Sanitation Options	17
2	Stages in Conventional Wastewater Treatment	24
3	Five Key Stages in the Decisionmaking Process	33
4	Key Sanitation Choices and their Implications	42
5	Options for Collection and Drainage of Wastewater	48
6	Level of Treatment Required for Wastewater Reuse	52
7	Pour Flush Latrine with Offset Single Pit	81
8	Pour Flush Latrine with Offset Twin Pit	83
9	Pour Flush Latrine with Septic Tank and Soakaway	85
10	Community Toilet Block	87
11	A Vacutug	89
12	Small Bore Sewerage	94
13	Oxidation Ditch	96
14	Rotating Biological Contactor	98
15	Anaerobic Baffled Reactor	100
16	Wastewater Treatment Process	103
17	Activated Sludge Process	107
18	Biological Trickling Filter	109
19	Fluidized Aerated Bed (FAB) Reactor	111
20	Upflow Anaerobic Sludge Blanket (UASB)	113
21	Upflow Anaerobic Filter	115

Boxes

1	The Limitations of a Norms-Based Approach	6
2	Alampur Sewerage Project: Successful Innovation and Partnership	8
3	The Community-Led Total Sanitation Approach in Maharashtra	9
4	NGO and CBO Roles in Service Delivery	10



भारत सरकार
शहरी विकास मंत्रालय
निर्माण भवन
GOVERNMENT OF INDIA
MINISTRY OF URBAN DEVELOPMENT
NIRMAN BHAWAN
नई दिल्ली-110011, तारीख दिसम्बर 4, 2007
New Delhi-110011, Dated the December 4, 2007

Foreword

As India moves ahead in the urban sector with major reform initiatives, like JNNURM and UIDSSMT, there is a need to address key capacity issues related to provision of basic services, in order to fulfill the underlying goals of these reforms. This is particularly true of the urban sanitation sector. Traditionally public policy on basic urban services in India has focused on water supply, which has enjoyed primacy in investments as well, while sanitation has lagged behind. Even today, almost one fourth of the urban populations in India do not have access to safe and adequate sanitation facilities. Inadequate access to sanitation especially in high density urban slum settlements is one of the key impediments to improving the quality of life and productivity of urban centers. In the absence of quick and effective remedial measures, we also run the risk of rapidly increasing vulnerability to disease caused by such conditions.

While urban India has invested significantly in sanitation infrastructure, this has essentially been focused on traditional sewerage networks, with some efforts directed towards individual and community toilets for economically weaker sections of society. These efforts have failed to deliver a safe sanitary environment in urban India as they typically lacked the comprehensiveness to address the full dimension of the sanitation challenge existing in the country. In particular, these efforts have failed in terms of targeting the sanitation needs of all sections of urban society, working towards triggering behavior change to ensure usage of the facilities created or their proper operation and maintenance.

Given the experience in the sector thus far, it is imperative that future efforts consider a range of technical options ranging from on-site to traditional centralized sewerage and treatment systems, on techno-economic considerations, so as to draw up plans that are comprehensive and inclusive enough to cover all geographical locations and all sections of society. Total sanitation, in its fullest sense, must be the underlying objective of these plans. Capacity building in this regard through documentation of appropriate sanitation technology options and their techno-economic implications, is a key need of the hour.

Towards enabling Sustainable Cities...

In this context, these guidance notes titled '**A Guide to Decisionmaking—Sanitation Technology Options for Urban India**', which have been developed by the Ministry of Urban Development (MoUD) with support from the Water and Sanitation Program-South Asia, are extremely timely. The documentation focuses on various technology options for provision of access, O&M and disposal arrangements related to sanitation services. While it has primarily been prepared to provide municipal agencies with the required sound technical advice on the planning of new investments and the delivery of sanitation services, it is also aimed at sensitizing state governments and urban local bodies in this regard. The documentation also provides guidance on implementation and financial issues, in addition to technical details.

The guidance note should be considered as an evolving document and a “work in progress” to enable it to grow on the basis of the actual experience of cities across the country. It is applicable to small interventions in specific locations and also to larger programs that aim to improve sanitation citywide. They are not aimed at being a set of rigid, exhaustive prescriptions, and should be adapted to the cities' specific circumstances in their application.

The Ministry of Urban Development wishes to thank WSP-SA and the various state and city authorities for their assistance in the preparation of these guidance notes.



M. Ramachandran

Secretary

Ministry of Urban Development



सत्यमेव जयते

भारत सरकार
शहरी विकास मंत्रालय
निर्माण भवन
GOVERNMENT OF INDIA
MINISTRY OF URBAN DEVELOPMENT
NIRMAN BHAWAN

नई दिल्ली-110011, तारीख दिसम्बर 4, 2007

New Delhi-110011, Dated the December 4, 2007

Message

South Asia contains more people without safe sanitation than any other region in the world. It is estimated that 17 percent of the urban population in India currently has no access to any sanitary facilities, while 50-80 percent of wastewater is disposed of untreated.

It is recognized that urban sanitation is dependant on a combination of sewerage and other on-site options and a great majority of urban residents are and will remain dependent on on-site sanitation facilities such as pour flush toilets discharging to leach pits or septic tanks. However, there is need to inform the people and the utilities on appropriate disposal of the waste and maintenance of the facilities.

In addition, municipal planners need to recognize that the worst sanitary conditions usually exist in areas inhabited by the poor and the sanitation needs of these areas need to be addressed on priority. Construction of a toilet is generally regarded as the householder's responsibility but for poor households, investments in sanitation are often constrained by various issues including affordability and uncertainty over land tenure.

Special measures may therefore be needed to support service improvements for the poorest sections of the community. This does not mean subsidies and awareness campaigns only but also technology options along with a proper operations and maintenance plan, which suits the local context of these communities.

These guidance notes have been drafted to aid decisionmakers and practitioners, fully understanding the roles of each stakeholder to ensure a pragmatic and holistic sanitation plan which will focus on achieving sustainable outcomes. These guidance notes are designed to provide state governments and urban local bodies with additional information on the available technologies on sanitation and to aid them with how best and when to install them. I am confident that the guidance notes will contribute to triggering initiatives that could potentially lead to significant improvements in urban sanitation provision.

It was a privilege for me to be associated with the development of this document and I hope that the stakeholders will find them useful. I am sure that the guidance notes shall help them in realizing the vision of total sanitation. I extend my sincere thanks to the authors and peer reviewers, Water and Sanitation Program-South Asia (WSP-SA), and the various state and city authorities for their support and help in the drafting and preparation of these guidance notes.



A.K. Mehta
Joint Secretary
Ministry of Urban Development

Introduction

What this Guide is about

Poor sanitation is endemic in towns and cities across India and exacts a heavy toll on public health. In response, the Government of India has made increased funding available for the qualifying cities for sanitation infrastructure via the Jawaharlal Nehru National Urban Renewal Mission.

These resources are sorely needed, but money alone cannot solve the problem; municipal agencies need sound technical advice on the planning of new investments and the delivery of sanitation services.

This guide aims to meet some of those needs by providing advice on the selection of technology options for urban sanitation, whether for new infrastructure or the upgrading of existing services. It is applicable both to small interventions in specific locations and larger programs that aim to improve sanitation citywide.

Who is it for?

The guide has been written for both technical and nontechnical professionals responsible for urban sanitation. It is primarily intended for city managers, who may need to make decisions on sanitation investments but may not have an engineering background. The guide should help managers to make appropriate choices with simple steps and engage effectively with technical specialists.

Structure of the Guide

The guide comprises four parts:

- **Part A** sets technology selection in the context of the range of issues and challenges that urban sanitation programs need to address.
- **Part B** provides an introduction to sanitation technology for nontechnical specialists.
- **Part C**—the heart of the guide—sets out a logical process for technology selection, both for new services and upgrading.
- **Part D** is a 'toolkit' comprising information sheets on sanitation technologies; management options for service delivery and maintenance; and various communication tools to facilitate community consultation and participation in decisionmaking.

Scope of the Guide

The guide focuses on technology but takes into account the full range of factors that affect the outcome of sanitation investments.

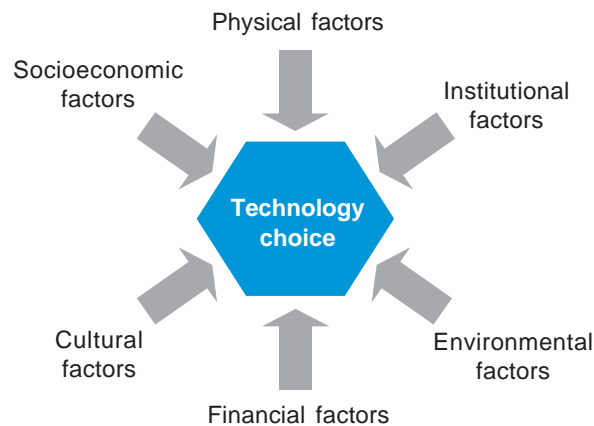

In many situations, on-site facilities may provide a more appropriate, cost-effective technology and, in some cases, an inexpensive option. The guide therefore pays particular attention to on-site options, including the removal and treatment of fecal sludge and septage.

Related Documents

The guide is concerned with technology choice but is not an engineering manual; neither does it address the strategic planning of sanitation services at city level.

For further information in these important areas, please refer to the following Government of India documents:

1. *The Manual on Sewerage and Sewage Treatment*. 1993. Prepared by the Central Public Health and Environmental Engineering Organisation (CPHEEO), Ministry of Urban Development. The manual is available for download from the CPHEEO website at <http://cpheeo.nic.in>
2. *Urban Sanitation in India—Planning for a Better Future*. Urban Sanitation Planning Guidance Notes. Ministry of Urban Development.
3. *Guide to City Sanitation Planning*. Ministry of Urban Development.

Acronyms and Abbreviations

Institutional abbreviations

CDP	City Development Plan
CPHEEO	Central Public Health and Environmental Engineering Organization
GoI	Government of India
ILCS	Integrated Low Cost Sanitation
MoUD	Ministry of Urban Development
NURM	National Urban Renewal Mission
WSP-SA	Water and Sanitation Program-South Asia

Technical abbreviations

BOD	Biochemical oxygen demand
IHL	Individual household latrine
NH ₃	Ammonia
SPPF	Single-pit pour flush latrine
SS	Suspended solids
TKN	Total Kjeldahl Nitrogen
TPPF	Twin-pit pour flush latrine
UASB	Upflow Anaerobic Sludge Blanket
VIP	Ventilated Improved Pit
WWTP	Wastewater treatment plant

Part A

Setting the Scene





Before considering any technology choice, it is useful to first define sanitation, and then consider the urban sanitation problems faced across India and the sort of interventions needed to resolve them.

Defining Sanitation

For the purposes of this guide, ‘sanitation’ refers to *the safe management and disposal of human excreta*. It is important to understand that this involves service delivery, not just the installation of infrastructure; both service providers and users need to act in defined ways. This means that the success of sanitation investments cannot be measured only in terms of physical outputs such as the number of toilets built or kilometers of sewer laid. Instead, the focus of attention should be on *outcomes*, primarily the use and maintenance of those facilities.

Dealing effectively with human waste may also require action in related areas such as water supply, drainage, and solid waste management. Good coordination between the agencies responsible for these services is, therefore, important.

Urban Sanitation: What are the Challenges?

Broadly speaking, the challenges fall into four categories:

- Low infrastructure;
- Service coverage;
- Low service usage; and
- Weak institutional arrangements.

Low Infrastructure Coverage

South Asia contains more people without safe sanitation than any other region in the world. While infrastructure coverage is gradually improving, it has so far failed to keep pace with the rate of urban growth. In India it is estimated that 17 percent of the urban population currently has no access to any sanitary facilities at all, while 50–80 percent of wastewater is disposed of without any treatment (Draft National Urban Sanitation Policy, 2007).

It may take several decades for sewerage and other sanitation services to become available to all of urban India. In the meantime, the great majority of urban residents will remain dependent on on-site sanitation facilities such as pour flush toilets discharging to leach pits or septic tanks. Municipal sanitation plans should therefore include measures to improve on-site sanitation—otherwise they will meet the needs of just a small portion of the city.

Municipal planners should also recognize that the worst sanitary conditions tend to be found in poor areas. Construction of a toilet is generally regarded as the householder's responsibility but, for poor households, investments in sanitation are often constrained by issues relating to:

- Affordability, including the cost of connecting to sewer networks;
- Uncertainty over land tenure (fear of eviction);
- Space constraints; and
- The low priority given to sanitation (people may not appreciate its importance).

Special measures may therefore be needed to support service improvements for the poorest sections of the community. This does not just mean subsidies and awareness campaigns; technology options are also needed that suit the physical conditions in poor communities.

Limited Access to Services

Official coverage figures do not, on their own, give the full picture regarding access to sanitation services. Existing arrangements can in fact be deficient in a number of ways:

- There may be a *complete lack of facilities*. For example, there may be settlements with no toilets at all, while facilities for the safe emptying of septic tanks, and the treatment of septage, may be lacking across the entire town.
- Sanitation facilities may be available but could be *inconvenient, unpleasant or unhygienic*. This may be the result of inappropriate design or construction, or inadequate management arrangements. Poor management is often a problem with community toilet blocks.
- Sanitation facilities may be available, but some people have *limited access* to them. For example, people may not be able to afford to connect to an existing public sewer.
- Sanitation facilities may be in place but are *not operated or maintained properly*. Poor operation and maintenance of a facility shortens its useful life and could, at worst, result in rapid total failure.
- There may be *no provision for the treatment of wastewater or excreta*. Local drains and sewers may simply relocate waste to another part of town where it causes local pollution. Households are primarily concerned about the cleanliness of their immediate surroundings and much less worried about the wider impact on the environment.

Low Service Usage

Even where toilets are available, some are not used or are underused, with family members defecating outside most of the time. This might be because the facilities are unacceptable in some way (for example, people may not be willing to share toilets), or because there is a long-held preference for open defecation. Alternatively, people may underuse their toilet because of misunderstandings about its functioning and maintenance. In the case of twin-pit pour flush toilets, for example, some people fear that the pits will fill rapidly if the toilet is used too often; and they may not know that the contents of a full pit can safely be removed manually once they have been given time to degrade.

Such problems indicate the need for effective communication in sanitation programs, so that community awareness, preferences and behavior are properly understood and then addressed through information, advice, and hygiene promotion.

Weak Institutional Arrangements

State agencies and municipalities sometimes make very large investments in sanitation infrastructure, but these do not always deliver their intended benefits. There can be several reasons for this, for example:

- The investments are made on an ad hoc basis when funds become available, without reference to an overarching strategy or plan.
- Within the state government and municipalities, sanitation has no ‘institutional home’, meaning that no single department or agency is accountable for it. Responsibilities for different aspects of sanitation are often assigned to a number of agencies, and coordination between them is not always good. There have been cases, for example, where a state agency has developed a sewage treatment plant even when there are no sewers in the town, then handed it over to a municipality that does not have the technical capacity or financial resources to operate and maintain it.
- Large capital investments are rarely matched with detailed arrangements—both practical and financial—for future operation and maintenance.
- Improvements are often implemented on a norms basis, meaning that technologies are selected without reference to local conditions or to the preferences of users. Therefore, the new facilities may not function properly, or may not be used as intended (see Box 1).
- Especially in smaller towns, municipal and line agency staff tend to have limited technical expertise or awareness of the range of nontechnical factors that affect the outcome of sanitation investments.

Box 1: The Limitations of a Norms-Based Approach

There is a strong tendency for municipal agencies to opt for conventional water-borne sewerage without first assessing the demand for it, or its technical feasibility and long term affordability.

Many sewerage systems malfunction or fail altogether, common problems being insufficient water to flush solids through the sewer pipes and high pumping costs.

Apart from the technical shortcomings, a common occurrence is that households fail to connect to new sewers after installation, especially when they already have septic tanks. Unless there is strong demand for connections, installing sewers can be a wasted investment.

There may, in fact, be other options that would suit local circumstances better. For example, in Ramagundam, Andhra Pradesh, the municipality worked closely with the community and developed a simplified, low-cost sewerage system serving 300 low-income households. The network uses shallow sewers leading into a communal septic tank.

Implications for Technology Choice

This guide does not attempt to address all of the challenges outlined above, but it is important to take them into consideration when considering technology options. Technology choice needs to be approached carefully, with proper reference to local conditions, the human and financial resources available, and the needs and preferences of service users. This includes ensuring that, for any technology selected, viable arrangements for operation and maintenance can be established and sustained.

Technology and Program Design

In order to maximize the benefits of sanitation investments, technology choice needs to be part of a planning process that addresses a range of factors affecting service delivery and use. This section highlights some key aspects of program design that have a bearing on technology choice.

Responding to Demand

Earlier in the text, it was suggested that government schemes tend to deliver infrastructure on the basis of norms and untested assumptions about what people need. As a result, schemes may be implemented where there is no demand—something that may only

become apparent when the new facilities are left unused or are misused so that they quickly fall into disrepair and are abandoned. Public toilet blocks that have been built without adequate public consultation often suffer this fate.

Today there is greater understanding of the need to respond to demand, which means providing services that people both want and are willing to pay for. This is not entirely straightforward, however, for several reasons:

- Though sanitary conditions may be poor, the demand for new facilities may be quite low.
- People tend to ask for what they know; there may be technically appropriate, low-cost options available but people are unaware of them.
- People tend to consider their personal needs without concern for the impact of their choices on the environment. For example, people may be quite happy to discharge their toilet into an open drain that empties in another nearby community.
- Municipal agencies may not have the human or financial resources to meet local demand; it may also be impractical to satisfy a range of preferences within the same street or neighborhood. For example, if a sewer has been installed it needs a lot of toilets to discharge into it, in order to work effectively; it is impractical to provide sewers for a minority of households while the remainder use leach pits or septic tanks.

For these reasons, simply responding to current demand may not be the best approach. Instead, it is often necessary first to *generate demand*, and then advise residents of potential options and their benefits or limitations so that people can make suitable choices—in other words, to *inform demand*. After that, the task is to develop the means of meeting the demand. The development of sanitation services, then, involves a mixture of technical and nontechnical tasks and this has implications for the range of actors that should be involved in sanitation programs.

Communication

Generating and informing demand requires good communication with the people for whom new services are being developed. Furthermore, once the facilities have been installed, households need advice and motivation on operation and maintenance. This is especially true in the case of septic tanks and twin-pit pour flush toilets installed under the Government of India's Integrated Low-Cost Sanitation Scheme. There is widespread misunderstanding over the functioning of this technology, not only on the part of users, but also among masons and even engineers. Many people use both pits at the same time, while others fear that the pits will fill up too fast and so use the toilet only occasionally. Clear practical advice is essential if the toilets are to be used and maintained properly.

An important question is who should take on the communication role. There is no single 'correct' answer here; what matters is to recognize the need for communication and make

arrangements for it. Some municipalities may be able to communicate effectively with residents via their own staff or ward councilors. There has been a good example of this in Alandur, Tamil Nadu (see Box 2).

Usually, however, municipalities do not have the right people for this job and it is necessary to appoint a third party, for example a nongovernmental organization to facilitate communication, promotion, and subsequent follow-up at the community level.

Some useful communication tools and techniques applicable to sanitation projects are provided in Part D.

Box 2: Alandur Sewerage Project: Successful Innovation and Partnership

Alandur is a small municipality adjacent to Chennai Metropolitan Development Area with a population of 146,000. Slums and squatter settlements constitute about a quarter of the total population. Before the project, almost 95 percent households had household toilets with individual septic tanks which discharged into open drains where much of it stagnated due to low flows, causing odor and offering sites for mosquito breeding. While a septage removal service was provided by the municipality, there was no treatment facility and waste was disposed of in low-lying areas beyond the municipal limits. Local residents were concerned about improving sanitation in the town and the mayor took up the challenge. A public awareness campaign—launched via meetings with elected councilors, resident welfare associations, and the public—succeeded in motivating the public to participate in an improvement project.

The project used conventional sewerage but developed an innovative approach to implementation based on a public-private partnership. The municipal leadership was highly proactive and ensured a high degree of transparency in all project transactions.

The funding agency insisted on a 'willingness to pay' study before proceeding with a loan, and this indicated that 97 percent of residents wanted a sewerage system and were willing to pay up to Rs 2,000 (US\$49)¹ per connection. The project cost of Rs 34 crore (US\$8 million) (excluding the treatment plant which was implemented with private investment under 'build, own, operate, and transfer' arrangement) was financed through a 59 percent loan component; 12 percent grant component (from the lending institution as well as the state government); and 23 percent public contribution, with the 6 percent balance funded from interest on deposits. Tamil Nadu Urban Infrastructure Financial Services Limited was nominated to coordinate project implementation and provided the necessary financial discipline.

¹ US\$1 = INR 41 (approximately, as of October 2007). Conversion rates are from <https://www.cia.gov/library/publications/the-world-factbook/fields/2076.html>; all conversions in the text are approximations.

Promoting Demand

People are more likely to support sanitation projects that are given a high public profile; public interest generates momentum and active community engagement. This is especially important where there is a need to eradicate open defecation, a problem that is best tackled as a communitywide issue. The objective should be to make the practice socially unacceptable.

One way of catalyzing community action might be to hold inter ward competitions and offer financial rewards to wards that achieve a complete end to open defecation. This is already producing impressive results in rural Maharashtra, where the Community-Led Total Sanitation approach has been introduced with great success (see Box 3).

Community-Led Total Sanitation is based on the principle that the public health benefits of sanitation can only be realized in full when all households in a community dispose of excreta safely; even if 90 percent use sanitary toilets, the remaining 10 percent that practice open defecation or discharge human waste into the street pose a risk to the entire community. This could cancel out the benefits of the investments made by the rest of the community.

While Community-Led Total Sanitation can be very effective in promoting toilet use, it should be remembered that this is only one part of the sanitation challenge in urban areas. There are other important issues that can only be addressed by the municipality itself, not least the treatment and final disposal of wastewater.

Institutional Arrangements for Sanitation Service Delivery

A critical step in technology choice is assessing whether effective operation and maintenance arrangements could be put in place for each option, given the human and financial resources available locally. Generally speaking, the more complicated the technology, the greater the need for specialist personnel and equipment. Simpler technologies, such as flush toilets with soak pits or septic tanks, offer better prospects for management at the household or neighborhood level. This suggests that it will be best to use simple technology options where these are viable.

Box 3: The Community-Led Total Sanitation Approach in Maharashtra

Since 2002 the state government of Maharashtra has implemented a strategy for promoting rural sanitation that focuses on ending open defecation rather than building toilets. The strategy—Community-Led Total Sanitation—emphasizes both collective action and individual commitment. It aims to create demand for sanitation at the community rather than at the individual level, facilitated by the local government, and provides cash rewards to *Gram Panchayats* [a unit of local government at the village level] for the achievement of open defecation-free status (the outcome) instead of relying on subsidies to accelerate latrine construction (inputs). Till 2007, a population in excess of 4.5 million has achieved open defecation-free status—a remarkable achievement.

Whether at a local or city level, it is important that roles and responsibilities for operation and maintenance are clearly established and accepted by the relevant parties. There are a variety of potential options for doing this and the municipality does not have to be the sole player; nongovernmental or community-based organizations and private contractors could all have a role to play and might offer manpower and expertise that is unavailable within government agencies. To make the best use of these organizations, it is important that contracts (or Memoranda of Understanding) for their involvement offer incentives for good standards of service delivery and impose sanctions where these standards are not met.

Box 4 provides two examples of the successful involvement of nongovernmental and community-based organizations in service delivery.

Table 1 provides broad guidance on the possibilities for management by the public sector, community organizations, and the private sector at different levels in the service hierarchy. It suggests that individual households will normally be responsible for managing on-plot and in-house facilities while community management is usually difficult or impossible beyond the neighborhood level.

Box 4: NGO and CBO Roles in Service Delivery

Community sanitation blocks in Mumbai

The Slum Sanitation Project was launched in 1995 under the umbrella of the World Bank-funded Mumbai Sewage Disposal Project. Its objective is to develop community-managed toilet blocks in the Mumbai slums, with a target population of 1 million. Innovative toilet block designs are used that include a small residential block for the caretaker and their family, enabling them to live on-site. Each caretaker is employed by a local community-based organization that is responsible for maintaining cleanliness and collecting user charges. The facilities are operated under Memoranda of Understanding with the Municipal Corporation, which provides power, water, and sewerage connections (where viable).

Community-managed waste stabilization ponds and aquaculture in Kolkata

Waste stabilization ponds were constructed around the city of Kolkata in the early 1990s under the Ganga Action Plan. Capital costs were funded by the Government of India while operation and maintenance were the responsibility of the state government. Due to low strength sewage flows, the ponds offered significant aquaculture potential, and as a result an innovative arrangement was developed for leasing out their operation to cooperatives of fishermen. Under the lease agreement, the cooperatives were made responsible for maintenance of the ponds, but could also carry out aquaculture in the facultative and maturation ponds.

Initially, short-term leases were granted to the cooperatives but, following positive experience, the period was extended to seven years. Each cooperative pays an annual royalty to the implementing agency (Rs 200,000, or US\$4,000, during first two years, Rs 300,000, or US\$7,000, for the next two, and Rs 450,000, or US\$10,000, for the final three years) but this still allows the cooperatives to generate a viable income.

Table 1: Possible Management Options for Urban Sanitation

Management option	Household ^a	Neighborhood ^b	Settlement ^c	District ^d / zone	Town/ citywide
Public	Monitoring required	Monitoring on behalf of the public	Possible	Possible (current norm)	Possible (current norm)
Community	Monitoring usage required	Service provider	Possible	No	No
Private	Yes (individual households)	Possible as service provider	Possible (if there is an incentive)	Possible (but rare at present)	Possible (but rare at present)

Notes:

- Household: A single nuclear family or an extended family living in the same building or on the same plot.
- Neighborhood: An area containing anything between around 10 and 200 households.
- Settlement: A more or less homogenous area, containing perhaps 200 to 1,000 households.
- District: A part of a town or city, often an administrative area or political division, but it could be a drainage basin.

Further information on management options is provided in Part D (Appendix C).

Legislation and Standards for Urban Sanitation

While there are no specific legal provisions relating to urban sanitation, there are a number of provisions relating to sanitation services.

74th Constitutional Amendment Act, 1992

Responsibility for the planning and delivery of urban services, including sanitation, lies with urban local bodies under local municipal laws and the 74th Constitutional Amendment Act, 1992. The 12th Schedule of the Act sets out a list of critical issues for the urban local bodies including, amongst other things:

- Urban planning;
- Regulation of land-use and construction of buildings;
- Water supply for domestic, industrial, and commercial purposes;
- Public health, sanitation, conservancy, and solid waste management;
- Protection of the environment and promotion of ecological aspects; and
- Slum improvement and upgrading.

Municipal Bylaws

These enable local bodies to discharge their functions and typically include, for example, a requirement for property owners to discharge wastewater without causing nuisance; and an obligation to discharge wastewater into sewers where available. There are, however, no specific provisions for the safe removal, cartage, and disposal of septage in urban areas.

The Environment (Protection) Act, 1986

This Act applies in principle to every establishment, agency, or individual discharging any pollutant into the environment. 'Pollutant' includes treated or untreated sewage. In principle, municipalities are required to comply with discharge norms for effluent released from sewage treatment plants and to pay water cess under the Water Cess Act, 1977.

Technical Norms for Best Practice in On-Site Sanitation and Wastewater Management

The *Manual on Sewerage and Sewage Treatment* of the Central Public Health and Environmental Engineering Organization, Ministry of Urban Development (MoUD), sets out technical norms for best practice in on-site sanitation and wastewater management. The manual covers planning, design, and construction aspects for a wide range of technical options; it also includes operation and maintenance aspects and safeguards to prevent water pollution under different soil and groundwater conditions.

The norms set out in the manual are not mandatory but provide guidance for engineers. The manual also makes reference to relevant Indian Standards and Codes of Practice notified by the Bureau of Indian Standards.

The most relevant include the following:

- **IS 1172:1993** – Basic requirements for water supply, drainage, and sanitation.
- **IS 12314:1987** – Code of Practice for sanitation with leach pits for rural communities.
- **IS 2470 (Part 1):1985** – Code of Practice for installation of septic tank: design criteria and construction.
- **IS 2470 (Part 2):1985** – Code of Practice for installation of septic tank: secondary treatment and disposal of septic tank effluent.
- **IS 9872:1981** – Precast concrete septic tanks.
- **IS 5611:1987** – Code of Practice for waste stabilization ponds (facultative type).
- **IS 10261:1982** – Requirements for settling tanks (clarifier equipment) for wastewater treatment.
- **IS 13496:1992** – General requirements for suction machines for cleaning sewers, manholes and so on.

In addition, the MoUD prepared a document entitled 'Technical Guidelines on Twin-Pit Pour-Flush Latrines' in 1992, which broadly follows the lines of IS 12314:1987 on leach pit construction in rural areas.

All Indian Standards' codes represent a standard of good practice and therefore take the form of recommendations. They are not mandatory unless made so under contract conditions and some are routinely ignored, for example the recommendation for the construction of soakaways, dispersion trenches, and biological filters to deal with the outflow from septic tanks; and for the regular desludging of septic tanks using specified equipment.

Part B

Introduction to Sanitation Technologies



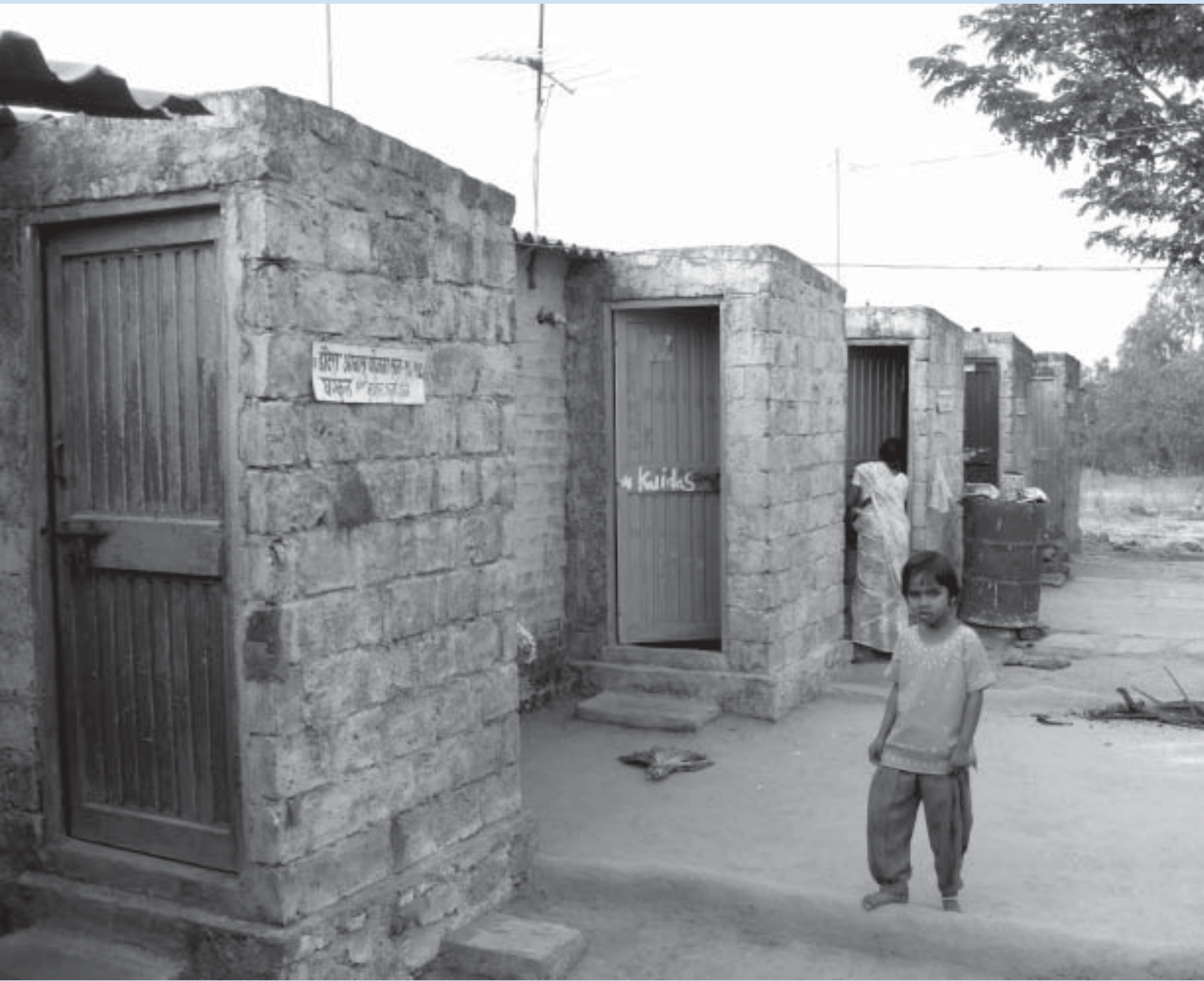

The protection of public health should always be the primary concern for those involved in the installation and operation of sanitation systems. It is also important to consider the environmental impact of poor sanitation and, as far as possible, to minimize pollution. In addition, there may be scope for the productive reuse of wastewater.

This section provides an overview of the technologies that may be employed to achieve these objectives.

Understanding Sanitation Technologies

Wet and Dry Sanitation

All sanitation technologies can be described as being either 'wet' or 'dry':

Wet technologies require water to flush feces. Most urban sanitation in India is 'wet', involving some form of flush toilet connected to a leach pit, septic tank or sewer.

Dry technologies² do not use water for flushing. They include a range of different types of traditional pit latrines, ventilated improved pits, as well as contemporary designs that promote the safe reuse of excreta.

Pit latrines are rarely used in India, though in recent years some small-scale initiatives have promoted ecological sanitation (known as *ecosan*), a form of dry sanitation that involves the separation of feces and urine at source and the reuse of treated excreta. In principle, ecosan has some important advantages including (a) reduced water demand for flushing; (b) reduced wastewater management problems (no blackwater production); and (c) improved nutrient recycling, particularly the nutrients in urine.

However, the traditional practice of using water for anal cleansing, and the availability of water to the majority of households in Indian cities, mean that flush toilets are likely to remain the preferred option for most households.

² 'Dry technology' is not widely used in urban India except in high altitude areas.

On-Site and Off-Site Systems

Sanitation systems may be:

- On-site, retaining wastes in the vicinity of the toilet in a pit, tank or vault.
- Off-site, removing wastes from the vicinity of the toilet for disposal elsewhere.
- Hybrid, retaining solids close to the latrine but removing liquids for off-site disposal elsewhere.

In urban areas, even nominally on-site systems will normally require periodic removal of the fecal sludge and septage from pits, tanks, and vaults. As a result, no urban sanitation system is completely self-contained. To achieve total sanitation in a town, consideration must be given to the way in which household services are linked with higher level transport and disposal facilities.

System Components

Every sanitation system includes some form of *toilet*. Most toilets in India consist of a water-sealed pan but a hole in a pit latrine cover is also a basic form of toilet. The toilet type is important because it will determine whether the sanitation system is wet or dry. This in turn will influence choices relating to other components of the sanitation system.

On-site and hybrid systems require *storage* in the form of a pit, tank or vault to retain fecal material pending desludging. Provision has to be made for the removal and *transportation of fecal sludge* to a disposal point.

Wastewater and fecal sludge require *treatment* before they are used either as an input to agriculture or returned to the environment. Waste collection and treatment systems may serve anything from a residential area of a few hundred houses to large urban areas.

Hybrid and off-site systems require provision for *transporting wastewater* from the toilet via a system of sewers to the treatment facility.

Possible Configurations of Components

Figure 1 shows the ways in which the components introduced previously can be brought together to create complete sanitation systems, distinguishing between wet and dry systems, as well as on-site, hybrid, and off-site systems.

Figure 1: Basic Sanitation Options

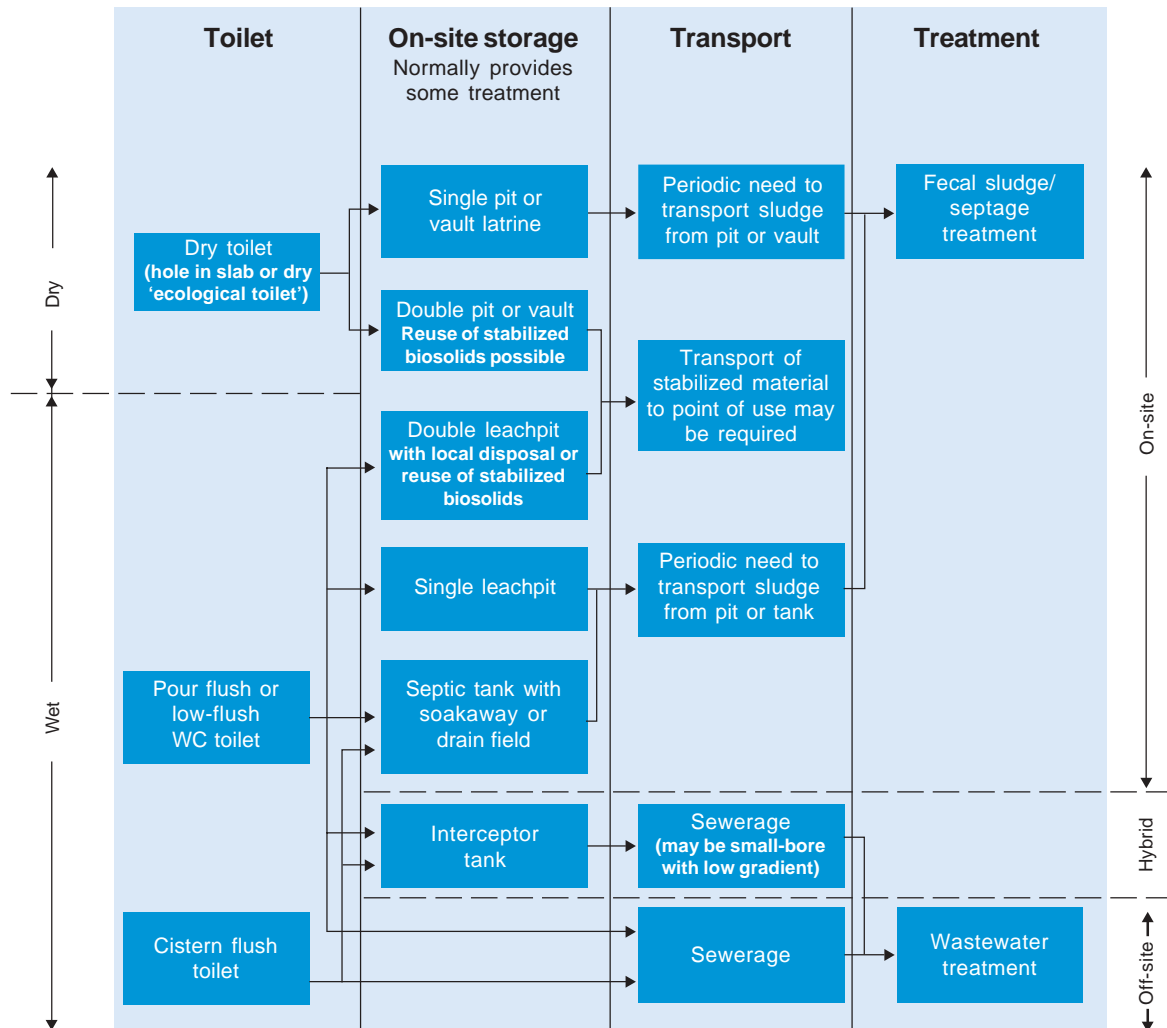

Note the following key points, not all of which can be deduced from Figure 1:

- The choice between wet and dry toilets will affect subsequent choices. Dry systems are always on-site, cistern flush toilets will require wastewater to be transported off-site unless there is sufficient land to provide a fairly extensive drain field, which will not normally be the case in urban areas. Both on-site and off-site options are normally viable for pour flush toilets.
- In all dry systems the pit or vault is located directly below the 'toilet', which may be nothing more than a hole in a slab. In effect, the toilet and storage are combined. The range of options for dealing with the wastewater produced by a water-flushed toilet is much wider.
- Choices will be influenced by what already exists. So, for instance, if most households already have a pour flush or cistern flush toilet, the choice will normally be between different wastewater disposal options.

- If a component is lacking, the sanitation system will be incomplete and will not offer the full intended benefits in terms of environmental health. Inadequate provision for the collection, transportation, and treatment of sludge from on-site systems is a widespread problem in India.
- Most on-site and hybrid systems require special arrangements for the removal and treatment of fecal sludge. The only exceptions are double pit and double vault systems which, if properly operated, remove the need to handle fresh feces.
- All off-site and hybrid systems require provision for wastewater treatment.

On-Site Systems

As indicated in Figure 1, on-site systems may be either wet or dry. If properly designed and managed, both wet and dry on-site systems can provide a service that is as hygienic and convenient as sewerage. Indeed, if water use is low, on-site sanitation may provide a better service than a poorly functioning sewerage system.

All on-site systems that are feasible in Indian conditions—whether wet or dry—require a pit, vault or tank to hold fecal sludge. All wet on-site systems are dependent on percolation of wastewater into the ground. Where water use is more than about 30 liters per capita per day, separate provision will normally be needed for sullage and storm water run-off. Where water use is low, the subsoil is sandy and sufficient space is available, it may be possible to dispose of sullage water by percolation into the ground. Normally, however, a separate drainage system for sullage will be required.

Further information on dry and wet on-site systems is given below.

Dry (Ecosan) Systems

As already indicated, all the dry or ecological toilets (ecosan) systems that are likely to be feasible in Indian conditions will also be on-site. In theory a single or double pit latrine could be used although these are not widely used or popular in Indian cities.

Some NGOs have installed ecosan toilets on a pilot basis in urban and periurban areas. Most of these use a double vault design with excreta stored in the first vault while the second is filling up and vice versa. The advantage of this system is that fecal material is stored for a period of about 12 months before it is removed, giving time for natural processes to break down the material and destroy pathogens and parasites. Urine is separated and should ideally be stored and used as a fertilizer. Anal cleansing is carried out away from the latrine hole to ensure that the vault contents remain dry. In order to prevent smells and nuisance caused by flies, fine ash is kept in a container in the latrine superstructure and sprinkled over the contents of the vault every time the latrine is used.

Ecosan has yet to be implemented on anything other than a pilot scale in India. It is too early to say whether it will prove to be acceptable to users and technically viable, though

compost toilets are prevalent in the mountainous regions of India. However, two observations can be made:

- Ecosan demands more from users (in terms of behavior) than other forms of on-site sanitation.
- There are many things that can go wrong, especially in separating feces and urine.

Therefore, before deciding to use ecosan, it would be important to ensure that the intended users understood and accepted what was expected of them; also that potential problems had been identified and systems put into place to deal with them.

Wet Systems

Wet on-site systems incorporate some form of water-flushed toilet from which feces and flush water are discharged into a pit or tank. The toilet is normally a pour flush pan. In some designs, the pit or tank is located directly under the toilet, but the normal arrangement is to provide a short length of pipe to connect the toilet to one or more offset pits or tanks. Having the pit(s) or tank offset makes it easier to desludge them. Figure 1 identifies three basic categories of wet on-site system:

1. Pour flush toilet to single leach pit.
2. Pour flush toilet via division chamber to twin leach pits [the model used in integrated low cost sanitation (ILCS)].
3. Pour flush or cistern flush toilet to septic tank.

Of these, the single leach pit option requires the least space, but the contents—including fresh feces—must be removed at intervals, creating the need for a hygienic pit emptying system. Similar systems will be required for septic tanks. The twin-pit system is designed so that (as with double vault dry systems) the pit contents are stored for a minimum period before they are removed, during which time the waste decomposes and pathogens die off. This means that treated wastes can be disposed of or reused without the health risks associated with handling undigested excreta. The main drawback with this system is that it will not work properly if users do not understand, or are not interested in, the way in which the system should function.

Septic tanks consist of a chamber or series of chambers into which wastewater is discharged and contained. Sediment and solids settle to the bottom of the tank and organic wastes are decomposed by the action of bacteria. The effluent from septic tanks may contain pathogens and should be discharged into a soakaway (or drain field). In practice, many septic tanks in India discharge effluent to the nearest open drain. Where drain fields do exist, they may not function effectively due to poor design and lack of maintenance.

Where ground conditions do not permit infiltration of treated wastewater, additional treatment in the form of a constructed wetland or anaerobic filter could be provided prior to discharge into a drain or watercourse. This option should only be considered if management systems for the treatment facilities can be guaranteed, a condition that very often cannot be met.





Sludge Collection and Transportation

On-site sanitation technologies are dependent on the periodic removal of fecal sludge from vaults, pits, and tanks. The most common practice is for households to pay sweepers to empty pits manually, though this carries health risks and is banned by the Constitution of India.

Sanitary pit emptying options exist, all incorporating some form of vacuum desludging equipment; examples are given in Table 2. These have a variety of tank sizes and pumping capacities, each appropriate for a different type of on-site service or settlement type. While some municipalities and private service providers offer a vacuum service, it is more expensive than manual pit-emptying and this tends to restrict its use to institutions and more affluent households. Shortcomings in emptying, removal, and disposal services lead to the widespread dumping of untreated wastes into open drains, fields and watercourses. This causes pollution and is a serious public health concern.

It is important to understand that simply collecting fecal sludge is insufficient; the sludge must also be treated. Fecal sludge treatment options will be discussed under 'Treatment of Wastewater and Fecal Sludge' (page 22).

Table 2: Sanitary Pit Emptying Options

Type of Vehicle	
<p>Conventional septic tank: Truck</p> <p>These are used in many cities in India but are expensive and have difficulties in accessing densely populated areas.</p>	 <p>Photo: Jonathan Parkinson</p>
<p>Narrow-wheel base truck</p> <p>Essentially the same as the above but with a smaller wheel capacity and wheel axle, enabling them to enter narrower lanes.</p>	 <p>Photo: Martin Strauss (SANDEC)</p>
<p>Trailer mounted desludger attached to a separate vehicle</p> <p>In South Asia, this system has been developed and promoted by the nongovernmental organization Dushtha Shasthya Kendra in Bangladesh (with the support of WaterAid) specifically to serve low-income communities in Dhaka.</p>	 <p>Photo: Peter Edwards</p>
<p>UN-HABITAT Vacutug</p> <p>The Vacutug is designed to provide a simple and inexpensive method for emptying pit latrines in areas where access by other forms of desludging equipment is not possible. The nongovernmental organization, Sulabh International, has been piloting the Vacutug in India.</p>	 <p>Photo: Iole Issaías (UN-HABITAT)</p>

Off-Site and Hybrid Systems

All off-site and hybrid systems incorporate cistern or pour flush toilets connected to sewers. In the case of hybrid systems the toilets are connected via interceptor tanks. Blackwater and sullage are normally combined on-plot and discharged to the sewer through a single household connection. In nearly all cases, sewage treatment is required before it can be safely discharged to the environment or used for irrigation or aquaculture.

Sewerage

Sewerage, the collective name for a system of sewers, consists of a network of buried pipes that convey wastewater from a house to the point of disposal. Sewerage relies upon a sufficient quantity of wastewater flow to convey solids along the pipe to a discharge point.

Sewers remove both excreta and sullage from the household and thereby negate the need for on-site servicing facilities. This makes sewerage convenient for users. Off-site wastewater disposal via sewers is most likely to be appropriate in higher density urban areas where water consumption is relatively high and soil permeability is low. However, sewerage is not a panacea. Silt and other extraneous material may block sewers and require periodic sewer cleaning, while blockages and overloading can cause sewage to overflow from manholes onto roads and pavements. Problems of solid accumulation are likely to be particularly acute where the available fall (slope) is limited; solid waste collection is poor; and there is lack of hard surfaces. Another requirement for sewer installation is an associated investment in off-site wastewater treatment prior to effluent discharge or reuse.

Conventional sewerage is expensive and various lower-cost options have been developed to improve affordability. These work on the same principle as conventional sewerage but incorporate modifications that take into account recent theoretical research and the possibility of matching standards to local conditions, as briefly described below.

1. **Reduced pipe diameters.** Condominial sewers in Latin America are laid with a minimum diameter of 100 mm rather than the 150 mm or 225 mm minimum standard that is common in South Asia. In theory, hydraulic efficiency increases as sewer diameter decreases. Reducing the pipe diameter reduces cost and increases structural strength. Blockages are likely to be detected quicker than in larger diameter pipes and this may mean that it is easier to clear them.
2. **Reduced minimum depth.** In residential areas where streets are narrow, traffic loadings are often much lower than those in more congested urban areas and house connections are relatively short. These factors allow the adoption of a lower minimum depth standard than that required by conventional standards. This can result in considerable savings.
3. **Access chambers.** Manholes are not required if sewers are laid at shallow depths. Access chambers are much cheaper and enable pipes to be cleaned without the need for a person to enter the chamber.

4. **Solids interceptor tanks.** These remove solids and so allow the use of small diameter sewers laid to lower gradients, reducing sewer depths throughout the system.

Treatment of Wastewater and Fecal Sludge

Treatment of wastewater and fecal sludge is required prior to discharge into the environment. This is especially important in situations where sources of drinking water are at risk from contamination or where local residents use rivers or drainage channels for bathing or washing and where the wastewater is reused for irrigating vegetables or horticultural crops.

The purpose of treatment is to reduce the concentration of potentially harmful materials to levels that will not cause harm to either the environment or the people that might come into contact with wastewater. The treatment required to achieve this objective will be influenced by the concentrations of pollutants and pathogens contained in the waste (see Table 3).

Table 3: Types and Sources of Domestic Wastewater and Fecal Sludge

Type	Source	
Fecal sludge	Pit latrines and leach pits	Decreasing concentration of pollutants and pathogens ↓
Septage	Septic tanks	
Blackwater	Water closets	
Domestic sewage	Sullage and blackwater mixed together	
Sullage (greywater)	Personal washing, laundry, cooking, and cleaning	

While some degradation of waste material may occur on-site in vaults, leachpits and septic tanks, there will almost always be a need for further treatment of fecal sludges, septage, and wastewater. While it is possible to provide this additional treatment on-site, the more common arrangement is to provide it *off-site or 'end-of-pipe'* (at the end of a sewerage system) or where fecal sludge cartage vehicles discharge wastes.

Because of their high concentration of pollutants and pathogens and relatively low volume, fecal sludge and septage should normally be dealt with separately from wastewater. For this reason, treatment processes for fecal sludge and septage are considered separately from those for wastewater below. Sullage is less polluting and less potentially harmful than sewage and blackwater, and will normally require a much lower level of treatment.

Treatment Standards

Treatment requirements depend largely on the proposed use of the effluent, but may also be governed by discharge consents if the waste is to be discharged into a natural watercourse. The purpose of discharge consents is to prevent unacceptable levels of pollution and risks to public health. In most towns little, if any, sewage is actually treated and standards set out in discharge consents are rarely met, even in cases where a treatment plant has been installed. The implication for regulatory bodies is that standards should be set at realistic levels in the light of local circumstances and tightened incrementally as local capacity for wastewater management increases.

Wastewater Treatment

Most wastewater treatment technologies use a combination of physical and microbiological processes to remove or degrade pollutants (see Table 4).

Table 4: Types of Treatment Processes

	Process	Mode of operation	Residual end products
Physical	Screening	Removal of large particles by coarse screening	Sludge
	Sedimentation	Force of gravity causes particles to settle	Sludge
Biochemical	Aerobic degradation	Breakdown of dissolved organic matter by bacterial activity in the presence of oxygen	Carbon dioxide, water and sludge (microbial biomass)
	Anaerobic digestion	As above but bacterial action in the absence of oxygen	Methane, carbon dioxide and sludge (microbial biomass)

Conventional aerobic treatment combines these processes in a series of stages as shown in Figure 2.

Figure 2: Stages in Conventional Wastewater Treatment

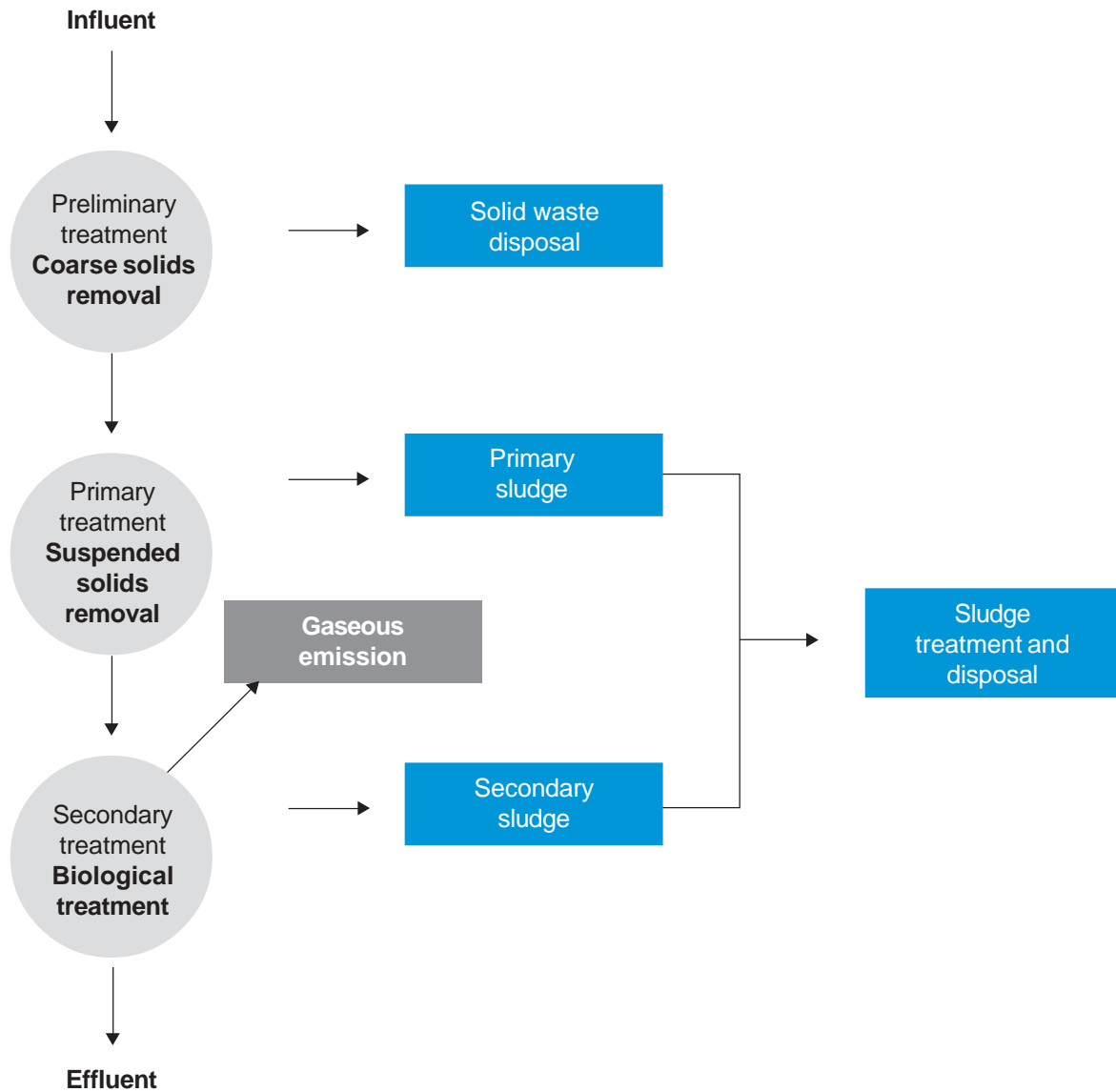

Preliminary treatment normally includes coarse screening and grit removal while primary treatment is provided in settlement tanks. In both cases, the predominant mechanism is physical. Secondary treatment processes, whether in trickling filters or by activated sludge, are predominantly biological. Table 5 provides information on the typical pollutant removal efficiencies for primary and secondary processes.

Where there is a need for further reduction in pathogens or nutrients, a tertiary treatment stage may be added to conventional aerobic processes. Most tertiary treatment processes are designed to remove nitrogen, phosphorus, and industrial pollutants such as heavy metals.

There are two broad alternatives to conventional treatment: extended treatment processes based on natural processes; and anaerobic treatment. The term 'natural' is used here to denote processes that represent managed versions of processes that can occur in more or less the same form in nature. The main treatment options in this category are waste stabilization ponds and constructed wetlands, which are also referred to as reed beds.

Anaerobic treatment processes include upward flow anaerobic sludge blanket (UASB) systems, baffled reactors and upward flow anaerobic filters.

Conventional treatment processes produce sludges that contain high concentrations of pollutants and excreted pathogens. Providing for the safe management of these sludges is an integral component of wastewater treatment but is often overlooked.

Fecal Sludge and Septage Treatment

It is normally advisable to treat fecal sludge and wastewater separately, though they can be combined in a wastewater treatment plant if the sludge loads are relatively small.

Options for separate sludge treatment include:

- Solids-liquid separation in batch-operated settling-thickening tanks;
- Primary sedimentation/anaerobic stabilization ponds;
- Sludge drying beds (unplanted; planted);
- Combined composting with organic solid waste (cocomposting); and
- Anaerobic digestion (potentially with biogas utilization).

Treatment results in two components: a solids and a liquid fraction. The solids fraction (biosolids) is of variable consistency—additional drying or treatment might be required for landfilling reuse in agriculture as a soil-conditioner and fertilizer.

Polishing treatment might be necessary for the liquid fraction too, to satisfy criteria for discharge into surface waters or to avoid long-term impacts on groundwater quality, where effluents will be allowed to infiltrate.

Reuse of Treated Wastewater and Sludge

Wastewater is used for irrigation in many parts of India, nearly always without pretreatment. Similarly, untreated fecal sludges are often used on fields or in fishponds.

These practices bring financial benefits to farmers but can harm the health of both farm workers and consumers of products produced using the waste. While this may be difficult to stop in the short term, pretreatment should be introduced in the longer term, possibly as part of the resource recovery process.

In the case of reuse, health risks from enteric pathogens must be reduced as much as possible. This is especially important where wastewater is used to irrigate parks and other public places, or food crops that may be eaten raw. Long retention in a waste stabilization pond system is recommended.

Where it is not possible to provide the required level of treatment (due, for example, to a shortage of land) then other strategies are needed to reduce health risks. These could include restricting the types of crops that can be irrigated with wastewater; using drip irrigation rather than spray irrigation; and providing farm workers with boots and gloves.

Stabilized biosolids make a good soil conditioner as they contain valuable nutrients and minerals. Wastewater is not usually suitable, however, due to a high concentration of dissolved salts.

Nutrients can also be reused as fertilizer for aquaculture, that is, for the cultivation of fish or aquatic plants such as duckweed.

Summary of Common Technology Options

Variations in housing type, density and settlement layout; poverty status; and access to networked services (especially water supply) mean that different solutions may be needed in different parts of the city or even within the same neighborhood. Rarely is a single option (for example, sewerage) viable for an entire town. For guidance purposes, Table 5 provides an idea of common upgrading options that may be appropriate for different settlements.

Table 5: Sanitation Options for Different Residential Settlement Types

	Settlement characteristics	Typical existing sanitation services	Key issues	Options for upgrading	
				On-site	Off-site
High-income residential	Low-density development with large plots and ample open space.	Most properties have septic tanks with or without a soakaway. In some cases there are sewer connections.	Septic tanks are often poorly maintained, and partially treated wastewater is discharged into open drains, creating a public health risk. Demand for water for irrigation of gardens.	Promote or enforce improved septic tank maintenance, including periodic emptying of pits. Addition of tertiary treatment at household level (anaerobic filter or reed bed).	Off-site treatment and disposal of septage. Sewerage combined with off-site wastewater.
Medium-income residential	Medium-sized plots with some space around houses.	Cistern flush and pour flush toilets connected to septic tanks or leach pits. Sewers are laid in some areas but system is only partial.	As above: on-site sanitation is often poorly operated and maintained. Partially treated wastewater is discharged into open drains, creating a public health risk.	Promote or enforce improved operation and maintenance, including periodic emptying of pits. Connect household toilets to small bore sewers which discharge into municipal sewers or to a decentralized wastewater treatment system.	Septage collection and off-site treatment. Sewerage combined with off-site wastewater treatment.

	Settlement characteristics	Typical existing sanitation services	Key issues	Options for upgrading	
				On-site	Off-site
Low-income residential (formal development)	Medium-density housing with small plots developed according to planning norms (road width, plot sizes, and so on).	Pour flush toilets connected to leach pits or septic tanks, the latter discharging into open drains or sometimes sewers.	As above.	As above.	As above.
Multistorey residential apartments	High-density, medium-low income.	Either connected to sewerage or have shared septic tanks.	Malfunction of septic tanks and soak pits.	Shared septic tank followed by: a) anaerobic filter and reed bed prior to discharge into surface water; or b) discharge to small bore sewerage system.	Septage transportation and off-site treatment. Sewerage combined with off-site wastewater
Low-income informal settlements	Unplanned development with medium- to high-density housing and small plots. Many plots subdivided and/or houses converted to multistorey. Residents may lack tenure.	Some households have no private facility. Existing leach pits and septic tanks discharging directly into street drains. Community or public toilets may be available. Inadequate drainage and water supply.	Septic tanks and leach pits are poorly maintained. Community toilets are often poorly maintained and unhygienic. Ponding of wastewater on surfaces.	Promote or enforce improved operation and maintenance, including periodic emptying of pits. Improved operation and management of community toilet blocks with septic tank or sewer connection.	Fecal sludge/ septage transportation and off-site treatment. Connect household toilets to small-bore sewers discharging to municipal sewers or decentralized wastewater treatment system.

	Settlement characteristics	Typical existing sanitation services	Key issues	Options for upgrading	
				On-site	Off-site
Illegal squatter slum settlements (jhughi-jhopri clusters)	<p>High-density, very low-income population, lack of tenure, precarious housing.</p> <p>Narrow access lanes with poor services.</p> <p>Quality of construction and servicing of facilities is very poor.</p>	<p>Some households have their own toilet.</p> <p>Many use shared or communal toilets, or practice open defecation.</p>	<p>Need to eradicate open defecation.</p> <p>May be insufficient space to build household toilets for all.</p> <p>Lack of land tenure may constrain spending on improvements.</p> <p>Existing toilets may discharge into street drains (<i>nalas</i>), creating a public health risk.</p>	<p>Pour flush toilets with leach pits or shared septic tanks where space permits; or</p> <p>Simplified sewerage connecting existing and new toilets to municipal sewerage network.</p> <p>Community toilet blocks with septic tank or sewer connection.</p>	<p>Fecal sludge/septage transportation and off-site treatment.</p> <p>Sewerage and off-site treatment of wastewater.</p>
Resettlement colony	<p>Medium-high population density.</p> <p>Basic infrastructure and some level of access to municipal services.</p>	<p>In some cases, development is planned and houses are constructed with toilets and leach pits.</p> <p>In others, many houses lack a toilet.</p> <p>Community toilets with septic tanks may be available.</p>	<p>Poor maintenance, inadequate services for fecal sludge collection and treatment.</p> <p>Open defecation may be common.</p> <p>Poor maintenance of community toilets.</p>	<p>Promote or enforce improved maintenance including emptying of leach pits.</p> <p>Provide communal toilet block(s) with:</p> <p>a) constructed wetland or anaerobic filter taking discharge from septic tanks; or</p> <p>b) sewer connection.</p> <p>Simplified sewerage connecting existing and new toilets to municipal sewerage network.</p>	<p>Fecal sludge transportation and off-site treatment.</p>

	Settlement characteristics	Typical existing sanitation services	Key issues	Options for upgrading	
				On-site	Off-site
Urban village, former rural village overtaken by urban spread	Medium-high density, mixed income.	Coverage variable; existing toilets mostly have septic tanks or leach pits discharging into open drains or <i>nalas</i> .	<p>Poor maintenance of toilets, inadequate services for fecal sludge collection and treatment.</p> <p>Open defecation may be common.</p> <p>Possible demand for wastewater from farmers.</p>	<p>Promote/enforce improved operation and maintenance, including periodic emptying of pits.</p> <p>Simplified sewerage in denser areas, with on-site treatment.</p> <p>Integrated wastewater treatment and resource recovery through aquaculture.</p>	<p>Septage transportation and treatment.</p> <p>Reuse of wastewater or sale of fish or animal feed.</p>
Institutional buildings (academic campuses, army cantonment, hospitals) and hotels	Large areas of open space surrounding large buildings.	Large septic tanks with soakaways.	<p>Poor maintenance.</p> <p>Unregulated septage removal and inadequate treatment.</p>	<p>Extended septic tanks (with baffles).</p> <p>Additional treatment (anaerobic filter or reed bed).</p> <p>Separate greywater treatment.</p> <p>On-site wastewater reuse.</p>	<p>Septage transportation and off-site treatment.</p>

Part C

Framework for Decisionmaking





Overview of the Decisionmaking Process

Part C sets out a step-by-step process for selecting technology and service delivery options that are appropriate under local conditions and best meet the needs and preferences of the community.

The decisionmaking process has been broken down into five key stages, as illustrated in Figure 3. Although the stages are presented as a sequence, in practice it may be necessary to revisit some steps as the process unfolds.

While working through the process, reference should be made to the Tools section of the guide (Part D). This includes information on sanitation and wastewater treatment technologies; management options; and tools for community consultation and planning.

Figure 3: Five Key Stages in the Decisionmaking Process

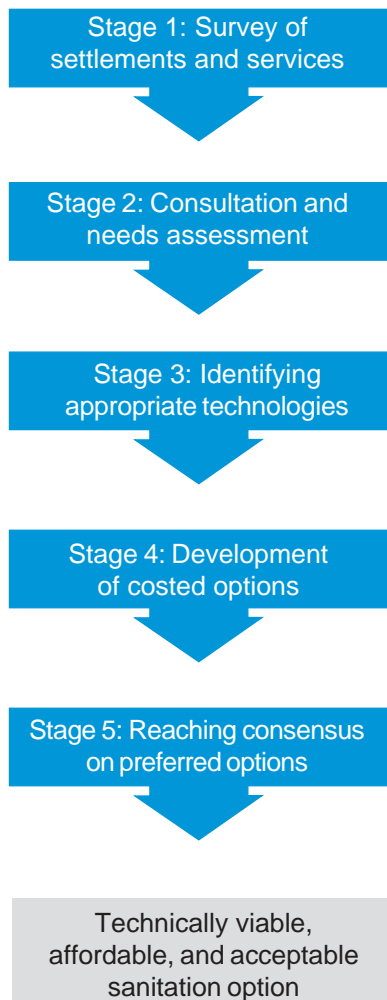

Stage 1: Outline Survey of Settlements and Services

The objective of the first stage is to gather information about the coverage and quality of existing services to clarify the key problems to be addressed and priority locations for improvement. This investigation might be done citywide or within areas of the town that have already been earmarked for attention. The information can be obtained from (a) maps and other secondary sources; (b) from a rapid physical inspection on the ground; and (c) from informal discussion with residents.

This preparatory work does not involve systematic user consultation, which follows in Stage 2. The output includes one or more maps that show the existing sanitation infrastructure and services, and highlights areas where sanitation problems are most acute.

Key Questions

- What sanitation infrastructure and services are in place, and how effective are they?
- Where are sanitation problems most acute?
- Where is there is a need for new infrastructure or services, and where is there a need for upgrading?
- Which areas should be prioritized for improvement?

Map Existing Land Use and Settlement Types

Existing city maps can provide a considerable amount of relevant information, but they rapidly become out-of-date as cities expand and new settlements spring up. A common problem is that unplanned informal settlements—often inhabited by poor communities and urgently needing improved sanitation—are literally off the map. It may therefore be necessary to prepare some simple but accurate up-to-date maps to ensure that these areas are not neglected in the planning of service improvements.

Table 6 sets out some key characteristics of residential settlements and shows how these can affect technology choice. While noting the current situation, it is also important to consider how a neighborhood may change in future. For example, increasing populations and housing density result in larger quantities of waste and place additional demands on sanitation infrastructure. The increased volume of excreta and wastewater produced per unit area may overload existing sanitation systems, and there may be insufficient space to install new household toilets.

Table 6: Settlement Characteristics and their Influence on Sanitation Technologies

Housing layout	Availability of private and public open space determines the scope for installing new facilities. Access for servicing vehicles may also be a constraint.
Housing type	Multistorey buildings usually need flush systems.
Land ownership	Affects entitlement to public services and householders' willingness to invest in sanitation improvements.
Socioeconomic status	Poorer communities may need assistance with the costs of household facilities or sewer connections.

An estimate of population density can be used to indicate the amount of available space for latrine construction and installation of treatment systems, but may be misleading if the area contains multistorey apartment buildings. A visit to the settlement would enable a more accurate assessment of the space available for toilets and on-site storage facilities.

Even where space for a toilet compartment can be found, there can be other constraints. For example:

1. *Insufficient storage space.* This is more likely to be a problem for vaults, which are normally raised above floor level, than for pits and tanks, which can be located below ground level, allowing that space to be used for other activities.
2. *Inadequate access for desludging of on-site sanitation systems.* In very dense informal settlements narrow roads may be a constraint for access by conventional pit desludging equipment. Alternative equipment, as described in Part B, may be needed.
3. *Insufficient space for wastewater absorption into the ground.* This will mainly be a problem for cistern flush toilets discharging to septic tanks followed either by soakaways or drain fields.

Gather Information about Existing Sanitation Infrastructure and Services

In most settlements, investments in sanitation will already have been made, whether by government agencies, households or others. The condition and functionality of these facilities will have a strong influence on the options for improvement. For example, household latrines may have been installed but without any provision for the collection, treatment, and disposal of wastewater. In other areas, periurban residents may be reusing wastewater for irrigation but without any form of treatment, which poses significant health risks.

Table 7 summarizes the information needed at this stage. Key questions to address include:

1. Is the existing infrastructure appropriate to local circumstances? Could it accommodate waste from additional sanitation facilities?
2. How effectively are existing facilities being maintained?
3. Is there an existing collector sewer or major drain in the vicinity of the area into which wastewater could discharge?

This assessment can be led by municipal or Public Health Engineering Department engineers but it may also be necessary to draw on the expertise of other agencies or private consultants for some issues (for example, problems with pumping stations or treatment works). Local residents can also provide valuable information and insights on

Table 7: Relevant Information about Existing Services

Latrines and on-site treatment	
Water availability	Information on existing water supply services (including daily consumption per household) can be used to estimate daily wastewater production.
Sanitation facilities	Current levels of service (household and shared facilities), including approximate household coverage and number and location of communal or public toilets.
On-site treatment	Types of on-site sanitation system serving households, for example, leach pit or septic tanks.
Waste collection and conveyance	
Existing sewerage infrastructure	Coverage of sewerage and proportion of households with household connections.
Fecal sludge and septage collection services	Coverage and frequency of servicing.
Off-site wastewater treatment and reuse	
Wastewater treatment	Location and types of wastewater treatment infrastructure (if any exists).
Discharge or reuse	Locations where wastewater and fecal sludge is disposed or reused.

the adequacy of existing infrastructure and services. Transect walks and informal interviews provide two options for obtaining this information rapidly (see Table 8).

Table 8: Participatory Tools to Assist in Initial Investigations

	Description of activity	Purpose
Transect walk	Transect walks involve a walk through the settlement accompanied by a small number of key informants from the community.	Provides an introduction to existing sanitation services and an initial understanding of the condition from the perspective of local residents.
Informal interviews	Informal interviews with community members to discuss aspects of sanitation service provision in their locality.	Help to understand the existing situation and analyze causes of problems that may not be immediately obvious to the outsider.

While municipal and other government agencies are the principal service providers, small-scale private enterprises may also have a role, for example, by emptying septic tanks. In addition, there may be nongovernmental organizations supporting sanitation improvements in some areas. Personnel from these organizations may have valuable knowledge and insights on the adequacy of current services and priorities for improvement.

Outcome from Stage 1

The outcome from this stage should be a clear understanding of the problems to be addressed, both in terms of location and type, at the household, neighborhood and city levels. It should also be clear which locations require new infrastructure or services and which are suitable for upgrading. While some of the challenges will relate to household facilities in specific locations, the survey may also reveal a need for improvements to secondary infrastructure, calling for an area-based approach, or to primary facilities such as sewage treatment plants and trunk sewers. Some problems may also point to a need for citywide improvements in the way that services are managed and delivered.

This information will provide the basis for a more detailed, participatory investigation in Stage 2.

Stage 2: Needs Assessment and Consultation

Key Questions

- What is the nature and extent of current sanitation problems from the users' point of view?
- What type of improvements would users prefer?

Stage 2 entails a more detailed analysis of the current situation to reveal what types of improvements are needed and where they will have the most beneficial impact. It involves further technical investigations in priority areas identified from Stage 1, plus an assessment of existing services from the users' point of view. This should provide a fuller understanding of why existing services have failed or are otherwise inadequate.

This is also an opportunity to find out what type of improvements users want and would be willing to pay for, or at least contribute towards.

Community Consultation

While residents may not fully understand the causes of sanitation problems from a technical perspective, they may be well aware of deficiencies in service delivery, for example the inadequate cleaning of drains, sewers, and poor maintenance of community toilets. Generally, it is important to draw on local knowledge as service users may have valuable experience and insights that are different than those of municipal staff. The consultation process can also be used to generate community interest in the proposed improvements, thereby improving the chances that any new facilities will be used and properly maintained.

Establishing the level of demand for improvements is critical, since people are unlikely to support (financially or through their behavior) services that they do not want. Where facilities are installed without consultation, on the assumption that people 'need' them, the result is often wasted investments: facilities that are left unused soon fall into disrepair and become unhygienic.

Organizing the Consultation

There is no single correct way to organize a community consultation exercise; much depends on circumstances including the type of community and the issues being investigated. It is, however, important that the process is participatory. With this in mind a range of operational tools is provided in Appendix A.

In practical terms, it is useful to hold not only public meetings with local stakeholders, but also household interviews and discussions with small groups to get detailed insights into people’s perceptions both of current problems and the possible solutions. Within this framework, a number of tools and techniques from the toolkit can be used; some commonly used ones are outlined in Table 9.

It is also advisable to consult local leaders and community representatives such as ward councilors and members of relevant community-based or nongovernmental organizations. Amongst other things, they should have a good understanding of how improvements could be managed at a community level.

Table 9: Participatory Tools Useful for Needs Assessment

Focus group discussions and semistructured interviews	Focus group discussions and structured interviews can be used to explore specific issues arising from surveys and participatory mapping in more detail.
Timelines	These can help to generate a clear understanding about what has happened in the past, what is happening now and what could happen in the future.
Community mapping	A representative group of residents is invited to make a map of the colony, showing key features relevant to sanitation (for example, open defecation areas, houses with or without toilets, location of sewers, and so on). This generates important baseline information and provides the basis for a discussion on the causes of current problems and possible solutions.
Questionnaire surveys	Questionnaires may be used to help focus and guide semistructured interviews of local residents, to learn more about their perceptions of sanitation and the problems related to fecal sludge and wastewater management.
Sanitation ladder	A set of pictures, each showing a sanitation technology option, is given to a group. They rank the options from best to worst; select one picture that best illustrates the current position in that colony and another representing the level of improvement they would like to reach.

It may not be advisable to hold consultations with all stakeholder groups at the same time as the presence of some, such as local politicians, may discourage the others from airing their views. Likewise, it may be advisable to hold some separate consultations with women only.

There are risks associated with the consultation because a poorly managed process can produce unreliable information or proposals that are unrealistic or do not represent the view of the majority of the community. It is therefore recommended that external specialists are contracted to facilitate the consultation process. An additional benefit of doing this is that residents may be more willing to speak openly to a third party than to a representative of the municipality.

At the end of the consultation exercise, stakeholders should have an opportunity to comment on the findings, including the priorities for action, and to correct any misunderstandings. The output from the various activities should therefore be recorded accurately, be it on paper or using photographs or audio tapes.

Outcome from Stage 2

The consultation should provide answers to both the key questions for this stage. This should include an indication of:

- ***Willingness to pay for improvements***

The extent to which residents are willing to pay for, or at least contribute towards, improved services indicates how strongly they want them. In Stage 4, specific costs and proposed community contributions for one or more technology options will be presented and discussed in detail. At this stage, a broad indication of willingness to pay should be sought and taken into consideration when compiling a shortlist of technology options.

- ***The level of service to be provided***

'Level of service' (see Table 10) refers to the location and convenience of sanitation facilities. There are three potential levels of service for toilets: household, shared or communal (public). Determining which level to provide is a critical step in the technology selection process.

Doubtless all residents would prefer to have a household latrine but this is not always possible, for a variety of reasons including affordability, land tenure restrictions or a lack of space. Where household toilets cannot be provided, alternative options will have to be explored and locations identified for any new facilities. (As a general rule, toilets shared by a small, self-selected group of households tend to be more heavily used, and better maintained, than communal blocks.)

Table 10: Level of Sanitation Service Provision

Household	The immediate access, convenience, and privacy offered by household sanitation will mean that this option will be the preferred option for residents. The main problems relate to the affordability for construction and the need to have a reliable servicing—notably for on-site sanitation systems—and the cost of installing a network of sewerage and off-site treatment if wastewater production is high.
Shared	In areas where there is not enough space for individual household latrines, the sharing of latrines between several families may provide a useful solution. The ownership of the latrines generally belongs to one of the houses, the owner of all the houses, or else ownership is shared between the households. Costs of pit emptying and other repairs can be included in the rent, but this can cause problems if the owner does not live there. Alternatively, residents can collaborate to clean the latrine and collect money to get it emptied when necessary.
Communal	Communal (or community) toilets are usually constructed in low-income residential areas and slums to cater to the local community who would otherwise have no access to sanitation. Provided these are managed well and maintained, this system can be effective in meeting the needs of the local community and promoting improved public health.
Public	Public latrines are provided for use for the general public in places such as bus stands, markets, and other facilities, which have a large throughput of people. One of the success stories of sanitation in India has been the public latrines developed by the organization Sulabh International.

Residents are generally more concerned about the cleanliness of their immediate surroundings than the wider impact on the environment caused by the discharge of untreated fecal sludge and wastewater. However, there may be an underlying public awareness for the need to improve the quality of the urban environment and to reduce pollution of natural watercourses.

- ***Specific concerns related to wastewater disposal or reuse***

In some communities, especially on the outskirts of smaller towns, there may be an established practice of reusing wastewater as fertilizer, though this may be unregulated and could pose a potential public health risk. If there is ongoing demand for this, the technical feasibility of doing this safely should be assessed in Stage 3. If there is no demand, then treatment and disposal will be needed.

Stage 3: Identifying Appropriate Technologies

Overview

The objective of this stage is to eliminate technologies that are unlikely to be viable from a technical perspective and thus narrow the field of options. The key question for each option at this stage is: ‘Could it work?’ A variety of additional factors (some of them financial and managerial) affect whether an option *would* in fact be viable and these are considered in Stage 4.

Key Questions

- Can wastewater be disposed of on-site?
- When and where is sewerage required and viable?
- What arrangements are required for the management of wastewater or fecal sludge?
- How does the demand for reuse influence the choice of technology?

Figure 4 sets out a logical sequence for assessing all the potential technology options. In practice, dry sanitation is not considered an acceptable option in India and it is not, therefore, investigated further in this chapter.

Figure 4: Key Sanitation Choices and their Implications

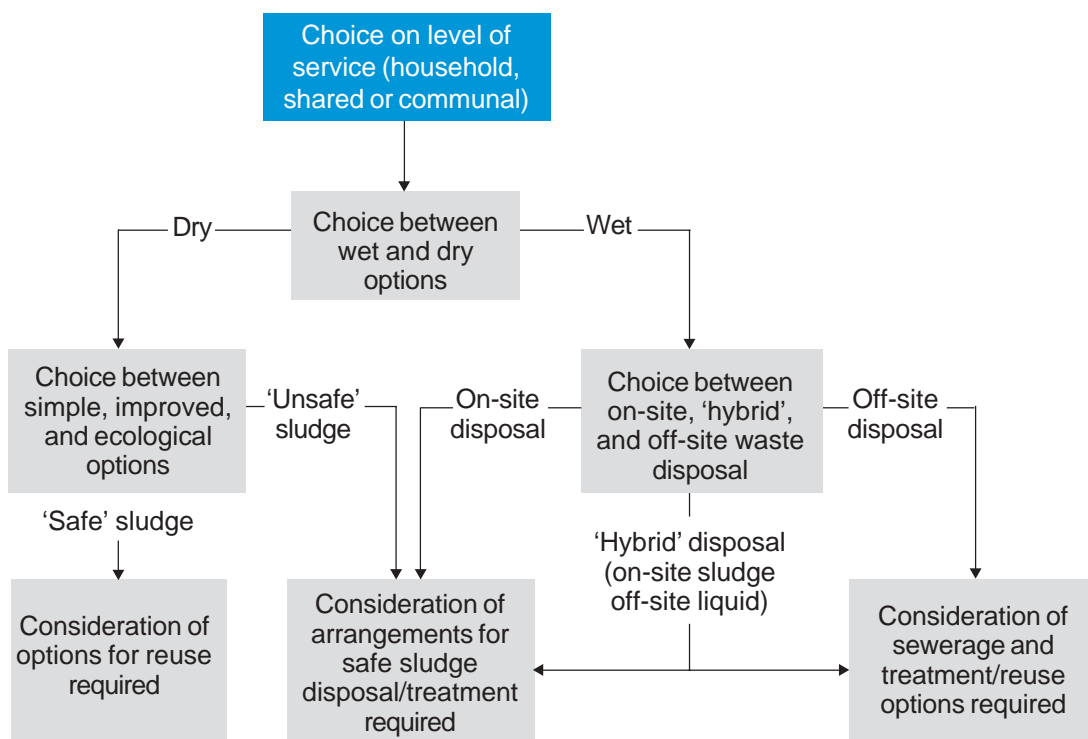

On-Site or Off-Site Disposal?

All forms of wet sanitation produce blackwater which has a high oxygen demand and may also contain high concentrations of pathogens. As illustrated in Figure 1, the options for dealing with this blackwater are:

- On-site disposal to a leach pit or drain field.
- On-site disposal to a septic tank with soakaway or drain field.
- On-site retention of solids in an interceptor tank combined with off-site disposal of settled wastewater (hybrid system).
- Off-site disposal of blackwater via sewerage.

The first and second options may require separate provision for disposal of sullage water while the third and fourth options work best if blackwater and sullage water are combined and dealt with together as sewage. The choice made between these options will depend on a number of factors including:

- The quantity of wastewater produced;
- Soil type, groundwater depth and topography;
- Housing density and available space;
- The source of water; and
- The presence of sewers and drainage channels into which local sewers might discharge.

These factors are considered below.

Quantity of Wastewater Produced

The total quantity of wastewater produced will depend on water consumption, which in turn will depend on the location of the water source and the length of time for which water is available each day (see Table 11).

Table 11: Approximate Water Consumption Figures for Different Levels of Water Supply Service

Type of supply	Water consumption (lpcd)		
	Minimum	Average	Maximum
Standpost	15	20	30
Yard tap, hand-operated well or in-house connection with intermittent supply	25	50	70
In-house connection or well with electrically powered pump	90	120	180

When per capita consumption is relatively low (less than 30 lpcd) then, depending on ground conditions and population density, it should be possible to deal with all of the wastewater on-site. When per capita consumption is higher, on-site disposal of blackwater is still possible, but sullage water will need to be disposed of off-site. Off-site disposal of all wastewater will be required if blackwater and sullage water flows are combined on-site to produce sewage (see Table 12).

Table 12: Relationship between Water Use and Disposal Option

Level of water use			
	Low <30 lpcd	Medium 30–80 lpcd	High >80 lpcd
Blackwater	Discharge wastewater to leach pit on or close to plot	Leach pit disposal possible if kept separate from sullage. Otherwise, sewerage and treatment required	Leach pit disposal possible if kept separate from sullage. Otherwise, sewerage and treatment required
Sullage (Greywater)	Discharge to soakaway or use for garden watering.	Soakaway disposal may be possible in permeable soils but off-plot disposal via a drain or sewer will normally be required.	Off-plot disposal—sewerage or drainage required.

The quantity of wastewater and, in particular, the quantity of blackwater produced is also influenced by the type of toilet used. Table 13 summarizes types of toilet and provides estimates of wastewater production based upon standard flush volumes and an estimate on the number of uses per day.

Table 13: Types of Toilet and Estimates of Water Consumption/Wastewater Production

Type	Description	Typical flush volume (liters)	Estimated wastewater per day l cap ⁻¹ day ⁻¹
Pour flush toilets	Use considerably less water than water closet toilets but have less appeal for more affluent households.	2.5	10–25
Dual flush toilets	Use less water than a full flush system (especially when used for flushing urine).	3/6	20–40
Full flush toilets	Use large volumes of water for flushing.	6–9	30–60

The key points to note are:

1. Full flush toilets use a significant amount of water and can only be used when a reliable water supply is provided via in-house connections.
2. Full flush toilets may create more blackwater than can be absorbed from an on-plot leach pit or soakaway, thus precluding on-site wastewater disposal.

Soil Type

The soil type will affect the operation of soakaways due to the infiltration capacity of the soil. Table 14 provides guidance on the maximum volume of wastewater that can be infiltrated on-site for different soil types. The last column calculates the maximum theoretical infiltration capacity for a 1 m³ (wetted area of 5 m²) assuming that there is no constraint due to clogging or waterlogging.

Table 14 shows the considerable difference in infiltration rate between clay and sandy soils. In areas with heavy clay soils, infiltration from leach pits and soakaways may not be feasible, whereas in sandy soils it may be possible to deal with flows from cistern flush toilets and even moderate amounts of sullage water on-site. Some caution is needed, since infiltration capacity will tend to reduce over time due to clogging with fecal solids from these theoretical values. Nevertheless, the figures given provide an indication for the potential for infiltration of treated wastewater.

Table 14: Theoretical Infiltration Capacity for Different Soil Types*

Soil type	Infiltration rate		
	mm hr ⁻¹	l m ⁻² day ⁻¹	Maximum capacity for a 1 m ³ pit (liters day ⁻¹)
Silty clay	0–1	0–24	0–120
Sandy clay	1–4	24–96	120–400
Silt	4–8	96–192	400–1,000
Sand	8–12	192–288	>1,000

* Assuming that the soil is free draining and not clogged.

In areas where the ground is rocky, it will be difficult and expensive to install pit latrines, septic tanks and sewers. In such situations, dry sanitation systems with chambers constructed partially or fully above ground level may provide a feasible sanitation technology.

In some parts of India, notably in the hilly areas in the north, the ground may become impenetrable during the winter months due to frozen soil conditions. In addition, latrines that use water for flushing excreta (such as pour flush latrines and water closets) may freeze and therefore dry latrines may provide an appropriate option in these situations.

Groundwater Level and Topography

In normal sandy and silty soils, the base of leach pits should be at least 1.5 m above the wet season water table. Where the groundwater level is near the surface, the scope for infiltration of treated wastewater into the soil will be reduced. Two possible options for overcoming these problems are:

- a) Install dry latrines with vaults partially or totally above ground level (as in the case for rocky soils described above); and
- b) Use drain fields instead of soakaways. These take up more space but promote infiltration into topsoil.

If neither of these options is possible, hybrid and off-site options should be considered. However, conventional sewerage will also be problematic where the topography is flat and there is a high water table, since the need to provide self-cleansing velocities will mean that many sewers have to be laid below the water table. This will lead to construction problems and potentially high rates of infiltration into sewers. The use of hybrid systems incorporating interceptor tanks can reduce this problem as solids-free sewers can be laid to much flatter gradients than conventional sewers.

Even where the groundwater table is low, conventional sewers can be problematic in flat areas. Laying sewers to self-cleansing gradients will result in high pumping costs. Experience shows that operators often attempt to reduce pumping costs by allowing the incoming sewer to surcharge. Surcharged sewers will silt quickly and thus need high levels of maintenance. In practice, there will often be a need for compromise between laying to self-cleansing gradients and keeping the depth of the sewer down in order to reduce pumping costs. One possibility in such situations will be to provide a hybrid system with interceptor tanks on house connections followed by solids-free sewers laid to flat gradients.

Housing Density and Availability of Space

As housing and population density increase, the volume of excreta and wastewater produced per unit area also increases, while space available decreases and may preclude the installation of household toilets. Even where space for a toilet compartment can be found, there may be other constraints, for example:

- *Insufficient space to store fecal waste.* This is more likely to be a problem for vaults, which are normally raised above floor level, than for pits and tanks, which can be located below a floor, allowing that space to be used for other activities.
- *Insufficient space to allow absorption of wastewater into the ground.* This will mainly be a problem for cistern flush toilets discharging to *septic tanks followed by either soakaways or drain fields*. Another factor to be taken into account is that seepage from leach pits and soakaways sited close to buildings can cause damp problems in buildings and result in structural damage. Damp problems can be countered by providing an effective damp-proof course.

Population density provides an indicator of the amount of open space available for the construction of latrines and treatment systems. Calculating the population density for a particular area will require field surveys during which other factors can be assessed. In particular, a quick qualitative assessment of typical plot layouts will provide information on the space available for toilets and on-site storage facilities.

In very dense informal settlements, narrow roads may be a constraint for pit desludging equipment. However, as described under 'Options for Removal and Transport of Fecal Sludge and Septage' (on page 49), alternative equipment is available which can be used in this situation.

The Source of Water

Where people rely on household wells and tubewells for their drinking water, the possibility of groundwater contamination must be considered. This is a potential problem mainly for on-site technologies. A minimum distance of 10 m should be allowed between a leach pit and a shallow well but this standard will be almost impossible to achieve in most urban areas. Where the groundwater table is more than 1.5 m below the bottom of the pit, the most likely contamination route will be along the side of the well or tubewell itself. This suggests that, if off-site technologies are not feasible, the focus should be on blocking the potential contamination route along the side of the well or tubewell, for instance by introducing a puddled clay layer.

Existing Facilities

The cost of off-site wastewater disposal will be reduced considerably if new sewers can be connected by gravity to an existing collector sewer or drain that has the requisite capacity.

Choice between On-Site and Off-Site Options: Conclusions

As a general rule:

- On-site options will be most appropriate in areas of low-density housing (typically less than 40 housing units per hectare), relatively low water consumption, and ground conditions that allow the absorption of wastewater without harm to an aquifer.

- Off-site options will be most appropriate where housing density is high (>40 houses per hectare), there is a reliable water supply on or close to the plot and sufficient fall is available to transport solids through the sewer without pumping.
- On-site disposal of blackwater via leach pits or soakaways, with off-site disposal of sullage water may be possible, even for relatively high density areas and relatively high water consumption, provided that ground conditions allow that and there is no problem of contaminating water supplies.
- Hybrid systems may be appropriate in medium- to high-density areas with a flat topography, particularly where the water table is high.

Further guidance on choices is given in Figure 5.

Figure 5: Options for Collection and Drainage of Wastewater

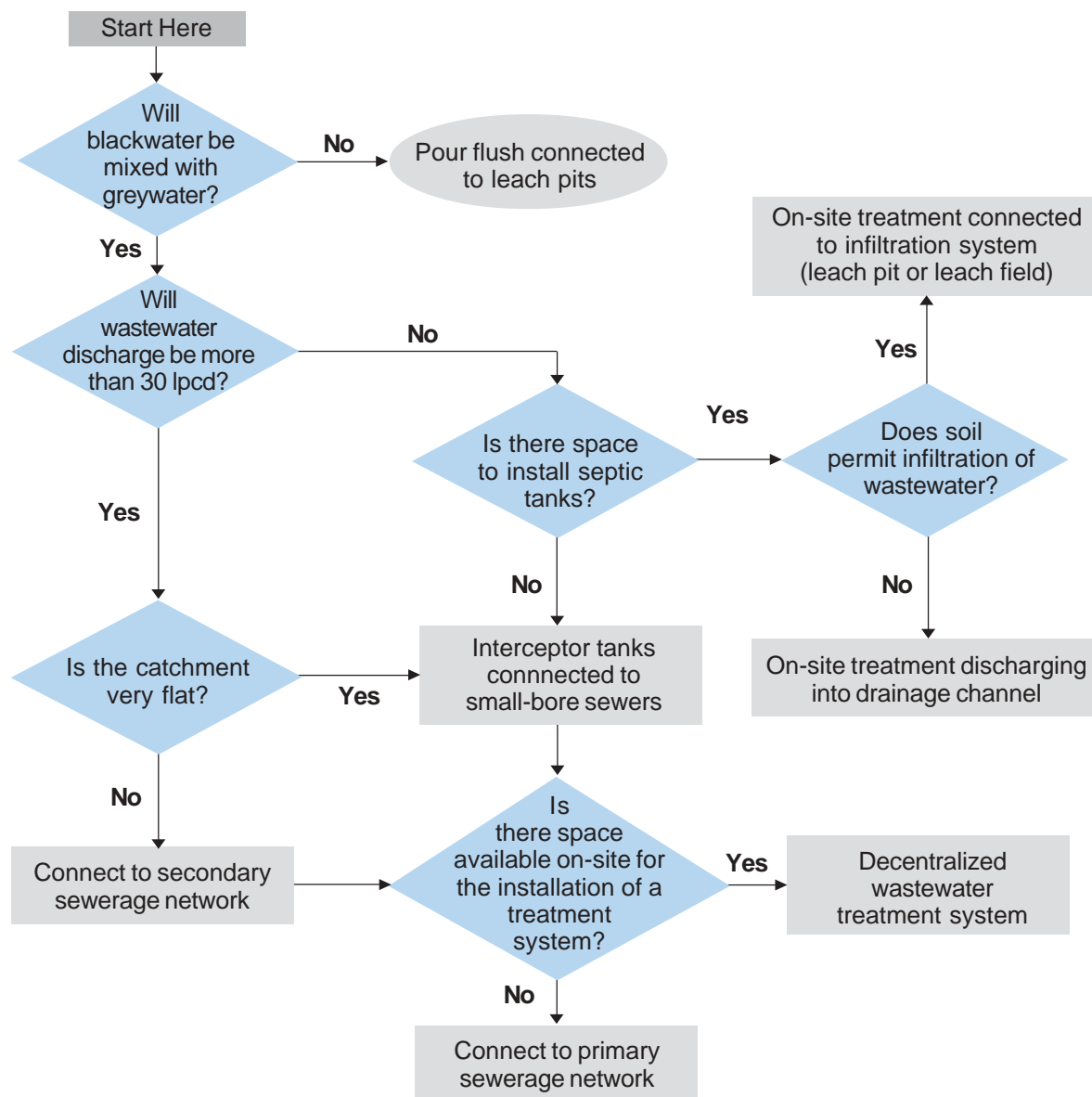

Options for Removal and Transport of Fecal Sludge and Septage

The long-term viability of on-site sanitation depends upon the availability of a service to remove fecal sludge and septage from pits or tanks, and then transport it to a suitable disposal facility. In most towns in India, only crude and unhygienic sludge removal services are available and so any proposal to introduce or improve on-site sanitation facilities should include consideration of sanitary options for the collection, transport, treatment, and disposal or reuse of fecal sludge and septage. This section deals with options for removing and transporting sludge while ‘Treatment Options’ (on page 51) deals with treatment options. Table 15 summarizes the different types of sludge, their characteristics and the implications for sludge collection and transport systems. Manual removal of untreated waste poses a significant health risk and should be avoided. As a result some form of motorized pumping equipment is recommended (see Part B).

Table 15: Types of Fecal Sludge and Implications on Cartage

Source	Characteristics	Emptying and cartage implications
Dry pits/vaults	Highly concentrated quasi-solids with high pathogen content (depending upon residence time in latrine).	Vacuum desludging systems are required for cleaning of single pit latrines.
Leach pits	As above, but higher moisture content.	Twin pits can be emptied manually without the need for specialized equipment.
Septic tanks	Varies enormously depending on the number of people utilizing the septic tank, water consumption, tank size, and pumping frequency.	Septage vacuum trucks are widely utilized for cleaning of septic tanks.

If it is not possible to guarantee hygienic collection, transport and treatment systems, the option of installing twin-pit systems, from which pit contents can be safely removed manually without the need for special disposal arrangements, should be considered. Note, however, that:

- This system only works if the pit that is not in use has been left undisturbed without water logging for a period of 18 months; and
- Users must be educated to use the pits alternately as required by the design.

Informal discussions with the users of twin pit ILCS latrines suggest that the second requirement is not always met at present.

Another question to be asked is who will be responsible for emptying twin pits. It is often assumed that the householder will do it but it is more likely that householders will employ sweepers. Again, user education is important to ensure that both users and those who empty pits are aware of the health risks associated with handling fresh feces.

Sewerage Options

All off-site and hybrid sanitation options require sewerage to transport wastewater to the point of disposal. The options for sewage disposal relate to the type of sewerage adopted and the extent of the system.

Sewerage constructed in accordance with conventional standards tends to be expensive to install and to maintain—especially where pumping is involved. Maintenance costs are likely to be high in areas with inadequate solid waste management or large unpaved and ungrassed areas, which are likely to generate high silt loads. Construction costs can be reduced by adopting standards that are appropriate to local conditions while pumping and maintenance costs may be reduced by installing interceptor tanks on household connections. Possible options for reducing the cost of sewerage are given in Table 16.

Shallow sewers are, in essence, conventional sewers constructed to relaxed standards. In particular, the shallow depth made possible by low traffic loads and short connection lengths allows the use of inspection chambers rather than manholes. Since these are not designed for entry of persons, they can be much smaller and cheaper than manholes, thus considerably reducing the cost of sewerage.

A type of shallow sewerage known as ‘condominial’ sewerage was developed in Brazil. As with shallow sewerage, sewers are laid at a shallow depth. Where possible, sewers are laid in private land, at the front or back of plots, or in sidewalks. The original assumption was that householders would take direct responsibility for sewers in private land although it seems that this practice is not as widespread as originally envisaged in Brazil. The condominium option may be feasible in some relatively low-density periurban settlements in India but is less likely to be applicable in high-density areas where houses commonly extend to both the front and back of plots, and there is no sidewalk. In such areas, it would be more appropriate to consider the use of shallow ‘lane’ sewers.

Another consideration is whether to design on the assumption that wastewater and storm water are disposed of separately. The accepted view is that separate systems should be the norm but there are likely to be situations in which it is very hard to separate flows on-plot, in which case the possibility of a combined system should not be discounted.

Table 16: Alternative Sewerage Options for Residential Areas

Terminology	Description	Benefits	Where it could be applied	Limitations
Shallow sewers	Sewers are laid to shallow depths and manholes are replaced with access chambers for cleaning.	Reduced cost and ease of maintenance.	In residential areas where traffic loads are low.	Protection, in the form of concrete surround or cover slab, required at road crossings.
Small-bore sewerage (also known as solids-free sewerage or SITS—sewered interceptor tank systems)	Interceptor tanks on household connections and small pipes of 100 mm diameter.	Removal of settleable solids in interceptor tanks reduces sedimentation in sewers and allows them to be laid to much shallower gradients.	Where ground slope is low or the water table is high.	Regular removal of solids from interceptor tanks required. Vulnerable to illegal connections by householders.

Treatment Options

All disposal and reuse strategies require waste treatment in order to mitigate environmental pollution and health risks. The focus for on-site systems will normally be on the treatment of fecal sludges and septage. That for off-site systems will normally be on wastewater treatment, although there will also be a need to consider options for treating the sewage sludge produced during treatment.

The choice of treatment process will be influenced by:

- The effluent quality to be achieved, which in turn will depend on what is done with the effluent.
- Wastewater characteristics, in particular its strength and likely variations in flow.
- Location and availability of land.
- Operational requirements in relation to available skills and management systems.

Each of these is discussed below.

Required Effluent Quality

Most 'conventional' sewage treatment systems are designed to remove visually offensive solids, organic material, and suspended solids, all of which are likely to affect the quality of the receiving watercourse. The demand for wastewater reuse will have been identified in Stage 2 ('Needs Assessment and Consultation', on page 38). Suspended solids may also block drip

irrigation systems. However, the most important consideration when using wastewater for irrigation is the need to reduce pathogen levels. In general, the longer the retention time in the treatment facility, the greater the pathogen removal. WHO guidelines suggest that extensive waste stabilization pond treatment is required to achieve the microbiological standards required if wastewater is to be used for either unrestricted or restricted irrigation.

Figure 6 indicates the level of treatment that is required if the effluent is to be reused or discharged into a water recipient.

Figure 6: Level of Treatment Required for Wastewater Reuse

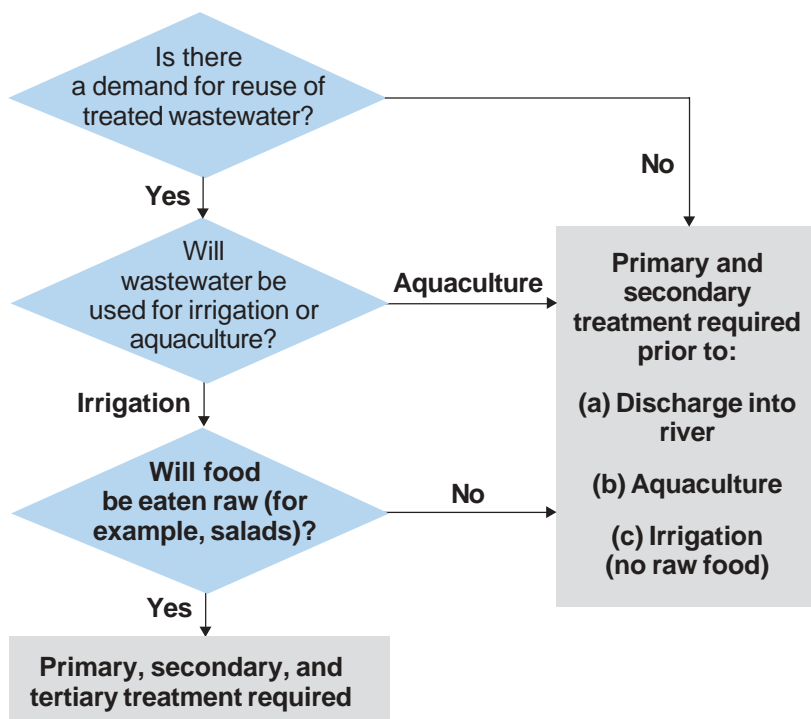

Wastewater Characteristics

The ways in which wastewater characteristics might influence the choice of treatment process are summarized in Table 17.

Location and Availability of Land

All wastewater treatment processes require land but the amount of land required varies considerably depending on the treatment process. As a general rule, less complex wastewater treatment technologies require more land than more sophisticated technologies. Anaerobic treatment technologies are fairly compact and decentralized systems can often be located on small parcels of public land. However, additional land will be required for additional treatment to achieve normal consent conditions. Natural aerobic wastewater treatment systems such as waste stabilization ponds and constructed wetlands require a large land area. For initial planning purposes, assume that activated

Table 17: Impact of Wastewater Characteristics on the Choice of Wastewater Treatment Process

Parameter	Notes	Technology choice
Flow rate	The average dry weather flow is proportional to the contributing population. Variations in dry weather flow occur during the day with peak factors decreasing as the contributing population increases. Storm flows can lead to large variations in flow even in nominally separate systems.	Some types of treatment systems—notably those which use a ‘sludge blanket’ or ‘attached biofilm’—are sensitive to variations in changes in influent flow due to possible washout of active bacteria. The shorter the retention period, the more sensitive they are to variations in flow.
Concentration	Concentration of wastewater varies considerably according to the source, the type of sanitation, the mix between blackwater, sullage and storm water, and time of day.	In general, anaerobic treatment systems are more appropriate for more concentrated wastewaters.
Presence of toxins	Wastewater in municipal systems that receive discharges from commercial and industrial sources may contain a wider variety of pollutants than domestic wastewater and therefore be more difficult to treat.	A more complex treatment system consisting of an increased number of unit processes and more advanced treatment is required to treat municipal wastewaters. Aerobic treatment systems are more suitable for combined municipal wastewater.

sludge treatment requires about 0.06 m² per person. Trickling filters and extended aeration will require rather more, perhaps up to 0.1 m² per person. More land will be required if high effluent standards are to be achieved. Waste stabilization ponds and constructed wetlands require much more land, typically 3–5 m² per person, depending on ambient temperatures. The advantage of these technologies is that their long retention period makes them more effective than other treatment methods in removing pathogens.

Where land is in short supply or expensive, the following options should be explored:

- Extend the wastewater collection system and site the treatment facility further from the town, where relatively inexpensive land is available.
- Use a more intensive treatment technology, even though this may be more expensive to construct and operate.

- Combine relatively local primary anaerobic treatment, perhaps in the form of baffled reactors or upward flow anaerobic filters, with extensive secondary treatment located at a distance from the town.

The second option will not be possible where there is a need to achieve high rates of pathogen removal, for instance when wastewater is to be used for unrestricted irrigation.

Anaerobic waste stabilization ponds should be located some distance from housing, ideally 1 km but at least 500 meters from the nearest dwelling.

Table 18 summarizes potential options for treatment of wastewater from different sizes of catchments from household up to the city level.

Operational Requirements and Performance Reliability

High-rate aerobic treatment systems are often highly mechanized and require sophisticated operation and maintenance. This needs large amounts of power for pumping and aeration. They are therefore at risk from power supply failures and cost of operation is prone to large fluctuations (normally increases) according to the cost of oil. This is a very important point since power outages are fairly common in India.

Discharge consents can be met by designing the treatment plant according to the appropriate hydraulic and organic pollutant loading parameters for each technology. Thus, to treat the wastewater to a higher level, it is generally possible to increase the size of the plant. But, this subsequently has implications on the amount of land that is required for plant installation.

Table 18: Options for Wastewater Treatment According to the Level of Centralization

Scale	Options
Household-level treatment	Septic tank with anaerobic filter connected to surface water drainage channel.
Small communal wastewater system	Baffled septic tank or septic tank followed by anaerobic filter or constructed wetlands.
Off-site (local) small-scale treatment systems	Waste stabilization ponds (if land is available). Reed beds (constructed wetlands).
Off-site (remote) large scale treatment systems	Waste stabilization ponds. Activated sludge process. Aerated lagoons.

Performance stability under variations in influent loadings will be an issue to consider as some treatment systems (for example, UASBs) are sensitive to such hydraulic or pollutant load variations. It is important to consider what might happen if treatment systems become overloaded. In many cases this will lead to the generation of septic conditions resulting in bad odors, which creates a nuisance for people living close to the treatment plant and adversely affects treatment efficiency and contaminant removal.

Other Factors

Sludge production and management: Smaller quantities of sludge are produced if anaerobic treatment is used compared with aerobic treatment. Large quantities of sludge to aerobic digestion processes can create a sludge disposal problem. Both aerobic and anaerobic wastewater treatment processes produce a highly concentrated sludge, which is generally treated on the same site as the wastewater treatment plant.

Emission of odorous and corrosive gases: Anaerobic digestion of wastewater and organic waste produces odorous and corrosive (methane and hydrogen sulphide) gases. Therefore, similar problems arise from septic tanks and sedimentation tanks (primary treatment), and anaerobic waste stabilization ponds should be located some distance from houses.

Biogas production: Anaerobic treatment becomes more favorable when treating high concentration wastewater and sludge, but the methane produced is malodorous and also contributes towards greenhouse gas emissions. Reuse of methane 'biogas' is more attractive as it can be used on-site for cooking, heating water or electricity generation. Although biogas production in itself does not provide a justification for adopting anaerobic treatment, it can provide an additional incentive for ensuring that the treatment system is well managed.

Output from Stage 3

Based on the considerations above, it should be possible to produce a shortlist of technology options for different areas.

Although there may initially appear to be a wide range of technological possibilities, the number of options that are practically feasible will probably be quite limited in the light of local circumstances, including the nature of the services already in place.

In Stage 4, the financial and operational viability of the shortlisted options will be tested to produce a final list of options.

Stage 4: Developing Costed Options

Stage 3 identified technology options that are viable from a technical perspective. In order that technology choices can be made, this stage estimates the capital and operating costs associated with each option over its anticipated lifetime, and considers how the new services could be operated and maintained. This should confirm whether the technologies are viable in terms of the human and financial resources available locally. For those that are viable, costed packages can be presented to the community in Stage 5 and agreement reached on the final choice.

Assessing the Costs

Detailed costings will not be needed until a technology option has been selected and works are to go ahead. At this stage, a reasonable estimate of the cost per household should be sufficient to indicate the relative affordability of each option.

In comparing the options it is important to consider the *full life cycle costs* of each. This means taking into account not only the capital and recurrent costs over the anticipated lifespan of new facilities, but also the need eventually to replace some components. Full life cycle costing might show that the option that is cheapest to install in the short term may not be the most cost-effective in the long term. Further information on life cycle costing is provided in Appendix B.

It should also be borne in mind that existing infrastructure represents 'sunk costs', meaning that the capital investment has already been made and will be lost if an alternative system is introduced. This may be an important consideration where households have already invested in facilities, such as septic tanks, that will become obsolete if sewers are installed.

Capital Cost

This should include all the components of a sanitation system: not only household facilities, but associated secondary and tertiary infrastructure if it is not already in place.

Caution is needed when determining the unit cost of technology options. Standard cost estimates used in government sanitation schemes may be out-of-date and quite unrealistic bearing in mind the current price of raw materials and labor. Wherever possible, new estimates should be made against standard designs, using current market prices for labor, components, and construction materials.

Capital costs should also include other project implementation costs such as:

- Training and other capacity building for municipal staff or service users;
- Communication costs, especially where a new technology or service delivery model is proposed;

- Community mobilization;
- Sanitation and hygiene promotion;
- Demand generation; and
- Strengthening the local supply of materials and skilled labor.

Operation and Maintenance Costs

Broadly speaking, operation means the running of a service on a daily basis, whereas maintenance refers to less frequent activities that are necessary to keep a technology in proper working condition.

Operation and maintenance costs are often underestimated or, at worst, overlooked altogether. Infrequent operations are the ones that are *most likely to be ignored and it is often these that are costly*. While costs can vary greatly according to local conditions, they are normally substantial for sewerage, especially in flat areas where poor solid waste management results in sewers being choked with garbage.

The allocation of responsibilities for paying capital and operation and maintenance costs also needs to be considered. Costs at household level are normally the responsibility of the users, in which case there is no direct burden on the local authority, but there may be indirect costs associated with monitoring and regulation. Where on-site sanitation is installed, costs at household level arise not only from the routine cleaning and care of household toilets, but also from the need for periodic emptying of pits.

Appendix B provides guidance on calculating capital and operation and maintenance costs for both on-site and networked services.

Sources of Funding

The affordability of technology options depends not only on their life cycle costs but also on the availability of dedicated funds from third parties. Where the bulk of capital costs are covered by a grant from the state or central government, or a donor, then the size of the initial outlay may not be of much concern to the municipality; operation and maintenance costs may pose a much greater challenge.

Revenue Potential

A realistic estimate of the revenue potential of new or improved services should be factored into the cost of providing the service. Unlike water supply, sanitation services suffer the problems of uncertain demand, significant capital costs and limited scope for revenue generation. Some municipalities seek to recover some sanitation costs via property tax or as a percentage of the water bill, but both are problematic and tend to generate only nominal sums. Where sewerage is proposed there can be a dual problem of high operational costs and the risk that only a few people will connect to the service. Where households use on-site facilities there is often no scope for revenue generation, though the costs to the municipality may in any case be minimal.

Pay-and-use toilets are the obvious exception here; where they are well managed, users are often willing to pay and this can generate sufficient revenue to cover operation and maintenance costs.

Revenue Potential from Wastewater Reuse

There may be scope to generate revenue from the sale of treated wastewater or sludge to farmers. In Rajasthan, for example, wastewater has traditionally been sold to farmers for much of the year. Other possibilities include combined wastewater treatment-reuse systems such as waste stabilization ponds combined with duckweed or water hyacinth aquaculture or fish production (pisciculture). The data sheet in Appendix A provides more information about treatment using duckweed. The revenues from such operations are unlikely to cover the full operation and maintenance cost of sanitation services but may subsidize them to some extent. However, a lot of land is required and, in some cases, the acquisition costs might cancel out any financial gains.

The Role of Subsidies

The risks associated with the use of subsidies were discussed in Part A. There may nevertheless be a case for some level of carefully targeted subsidy to stimulate household investment, provided a genuine demand for the new service has been identified. It may also be necessary to subsidize the transaction costs of project implementation. The availability of any subsidies, whether at household or municipal level, should be factored into the cost estimates.

Service Delivery and Maintenance Options

No sanitation technology, however simple, is entirely maintenance-free. Identifying how each of the potential technologies could be operated and sustained is an integral part of the decisionmaking process. There is no special methodology for doing this; this matter needs proper attention since operation and maintenance will not take care of itself. Any technology is only as good as the operational framework within which it is used.

Typical operation and maintenance tasks at household, neighborhood and city level are outlined in Table 19.

Table 19: Operation and Maintenance Tasks

Level	Typical tasks
Household level	Cleaning of toilets; emptying of leach pits and septic tanks; unblocking of household connections.
Lane and neighborhood level services	Management of communal septic tanks and toilet blocks; cleaning of lane sewers.
City level	Operation of sewage treatment plants, pumping stations and septage/sludge treatment facilities.

Contracting out

It is often difficult for local authorities to service and meet all maintenance needs. There is considerable potential for harnessing the resources of other parties—not least the users of the service themselves, who may know how best to provide services effectively at the local level, and can mobilize their own resources to supplement what the government provides. It may also be beneficial to contract out some aspects of service delivery or maintenance, particularly where skilled personnel or equipment are required that are not available in-house.

Key considerations in the assignment of operation and maintenance responsibilities at each level are outlined below.

Household and Shared Facilities

In most cases, users should be responsible for the operation, maintenance, and eventual replacement of household facilities and toilets shared by small, self-selected groups. There are nevertheless roles for the municipality in terms of:

Enabling

- Providing technical information and advice on the use and maintenance of the facilities; and
- Ensuring that local services are available for the safe emptying of pits and septic tanks and treatment and disposal of wastes.

Monitoring and Regulation

- Ensuring that households dispose of waste material safely; and
- Resolving operational problems as they arise, which may include enforcement action in cases of unsafe practices (such as the discharge of excreta directly into the street).

Lane and Neighborhood Level Services

Tasks at this level are listed in Table 19. In this case there are a range of possible institutional arrangements that might involve only the municipality (or a line department) but could include roles for community-based and nongovernmental organizations, individuals or private contractors.

City Level Services

Activities at this level include the operation of sewage treatment plants, pumping stations, and sludge treatment and disposal facilities. As with neighborhood services, there may be scope for the municipality or line department operating the service directly, but there may be potential gains from contracting out some services.

Appendix C provides further information on the various stakeholders in sanitation services, their potential roles and possible contractual arrangements. In practice, much will depend on the capacity of the municipality and, where this falls short, the availability of relevant expertise within the local private and nongovernmental organization sectors. Where tasks are assigned to a third party, the quality of service delivery will depend largely on the design and management of contractual arrangements. The challenge is to create incentives for good performance and to penalize poor performance. Where the private sector is involved, there must be scope for making a reasonable profit, otherwise there will be a strong incentive to cut corners and reduce the quality of work. Effective budgeting is, therefore, essential.

Output from Stage 4

At the end of Stage 4, options that would be unaffordable to the municipality, or for which the operation and maintenance prospects look poor, can be eliminated. For those options that remain (which may be only one or two in many cases) outline life cycle costs and potential management arrangements can be presented to the community in Stage 5 to reach a consensus on the final choice (see Tables 20 and 21).

Table 20: Comparative Life Cycle Costs of Technology Options

Option (examples)	Capital cost per household		Net annual operation and maintenance cost per household	
	User	Municipality	User	Municipality
1. Pour flush toilet with twin pits				
2. Pour flush toilet with septic tank				
3. Pour flush toilet with sewer connection				
and so on...				

Table 21: Management Options

	Proposed operation and maintenance arrangements		
	Household	Neighborhood	City
1. Pour flush toilet with twin pits			
2. Pour flush toilet with septic tank			
3. Pour flush toilet with sewer connection			
and so on...			

Stage 5: Reaching Consensus on Preferred Options

In the final stage, the options developed in Stage 4 can be presented back to the community. For each package, the technical, managerial and financial implications—including proposed operation and maintenance arrangements—need to be explained clearly. This should enable residents to engage in an informed discussion with municipal representatives resulting, hopefully, in consensus on the way forward.

Facilitating the Process

Stage 5 is, in effect, a continuation of the process begun in Stage 2, and again requires good facilitation skills. It is therefore appropriate that the agency that carried out the consultation in Stage 2 also facilitates the final activity, which could take the form of one or more public meetings; possibly also focus group discussions to ensure that the views of all stakeholders are heard. On this occasion, however, municipal representatives should also be present since negotiations and formal decisionmaking are involved.

Where on-plot sanitation is concerned, it may be possible to accommodate more than one design within the same street or neighborhood, but more commonly a single choice will need to be selected, especially where there will be sewers. This may require some degree of negotiation and compromise on the part of both users and the municipality, though this needs to be handled carefully, especially in relation to user contributions.

Detailed explanations of the design, function and maintenance requirements associated with each option should be provided, especially where a technology is unfamiliar to the community. It is best to visualize the presentation: scale models could be used but, for household facilities at least, a better idea might be to build one or more demonstration toilets, or take a group of residents to see the technology in operation elsewhere.

Some options may be unfamiliar both to local masons and to the community, so that training or technical advice would be needed if those options were selected. Further practical advice and motivation may be needed to promote good operation and maintenance postinstallation if an unfamiliar technology is adopted. This might focus, for example, on the emptying of leach pits or the need to avoid the clogging of sewers and drains with solid waste.

Even when local behavioral and cultural factors have been taken into account, some options may meet with a negative response due to residents' concerns over issues such as the level of service, cost sharing arrangements or operation and maintenance requirements.

Alternatively, the community may display only moderate interest in the options at first. This might not indicate that the options are inappropriate; rather it could indicate the need for a

promotional campaign to generate real demand before going ahead with any works. This might occur where the community's preferred option has proved to be nonviable, or where users do not perceive the importance of a proposed investment. There may, for example, be limited initial interest in making house connections to a proposed sewer if people have already invested in septic tanks which they perceive to be perfectly adequate.

Proposals for centralized facilities such as wastewater treatment plants might not generate much interest among residents since they have no direct impact at community level. This could make technology choice a simple matter for the municipality, unless there was a proposal to introduce or increase user charges for the service; people unconcerned about the safe disposal of effluent are unlikely to spend money on it. For the same reason, people might be indifferent to the proposed introduction of pit emptying and treatment services. Some level of hygiene promotion and awareness-building may be needed and, where current pollution problems are severe, the municipality may even need to consider a program of enforcement action.

If all of the proposed options are found to be unacceptable, then it may be necessary to revert to previous stages of the decisionmaking process and consider other technologies or service delivery and financing arrangements.

Outcome from Stage 5

The outcome of Stage 5 should be clarity and consensus on the preferred option(s) in technical, financial, and managerial terms. The feedback from this consultation should also enable the municipality to design an appropriate implementation process that encompasses not only physical works but addresses communication needs (not least for demand generation and hygiene promotion).

Part D

Toolkit



Appendix A: Participatory Communication Tools

Appendix B: Costing Technology Options

Appendix C: Institutional Options for Operation and Maintenance

Appendix D: Technology Data Sheets



Appendix A

Participatory Communication Tools

Community Mapping

Purpose

Community social maps represent a popular planning, evaluation, and monitoring tool because they reveal a lot that is never possible to know from written records. They help to visually represent and analyze the community situation regarding all water and sanitation facilities, including informal facilities as well as government services and those provided by specific projects. The mapping procedure helps to understand the access of different socioeconomic groups to these services. It also helps to assess which households pay for services (and how much) in relation to service access obtained.

To do social mapping well requires a considerable amount of time and excellent facilitation. The venue chosen for mapping should be a well lit central place, where a large group can gather for an extended period of time, protected from the weather, and accessible to all classes and both genders.

Preparation

A day before, facilitators discuss this activity with community representatives (both women and men) and agree on the area to be mapped. For project planning purposes, the entire population to be covered by a project intervention would have to be included.

For large settlements, it is often too cumbersome to map the whole neighborhood down to the household level. Instead, a general layout of the area is drawn showing relevant infrastructure and services, as well as the rich, poor, and intermediate sections.

Process

The facilitator explains the purpose of the exercise, and helps start a discussion to develop a list of features that need to be indicated on the map. Women and men make the map, either together or in separate groups, as gender relations allow.

The map is then drawn on a larger sheet of paper, or on the ground using locally available materials such as pebbles, colored powder, coins, twigs, leaves, and so on, to represent key features such as houses, temples, roads, and so forth.

The team uses the map to gather information and generate discussion on existing sanitary conditions and the type of improvements people would prefer. This would

include information on the number, type, and location of sanitation facilities, both public and private; and about households that do not have easy access to a sanitary toilet. The adequacy, reliability, and coverage of water supply services are also investigated since this affects the range of choice of sanitation technologies that could work effectively.

Pocket Voting

Purpose

This tool is particularly useful for eliciting information on sensitive subjects about which people feel inhibited to state their views publicly. In essence, a range of options or scenarios is presented, and then individuals make a secret 'vote' for one of them in answer to a question posed by the facilitator. People might, for example, use their 'vote' to confirm that they currently practice open defecation. The voting is done in the focus groups of men or women, rich or poor.

Process

The facilitator poses a question, and a set of pictures of sites representing possible answers is presented, typically by attaching them to a large cloth which is hung before the group. Under each picture is a small pocket sewn into the cloth. The cloth is then hung in a concealed place (for example, in a small room) and group members approach one by one to cast their secret vote by placing a small stone or token in the appropriate pocket.

After each voting session, the group lays out the votes for an analysis of the findings. The facilitator draws the group's attention to voting patterns to analyze similarities, differences, and changes. This provides the basis for further discussion on current practices or services and the need for change.

Pictures can be used to investigate many aspects of the current situation and also to find out what sort of improvements people would prefer. Useful information emerging from the use of this tool might include:

- Existing water sources and the purposes for which they are used. (For example: Are shallow wells used for drinking?)
- Defecation practices including the level of use of existing facilities by men, women, and children from richer and poorer households.
- Differences in behavior and preferences for improvement between women and men, rich and poor.
- The priority attached to sanitation as compared with other possible improvements in infrastructure and services.

Stakeholders' Meeting

Purpose

A stakeholders' meeting uses a variety of activities to stimulate and nurture open discussion on the issues under investigation, which in this case could be sanitary conditions in the community and priorities for improvement. Participants include representatives of public and (where relevant) private sector providers of water supply and sanitation services.

Process

In small- and medium-size towns, stakeholders' meetings are best organized at the ward or zonal level. A neutral place with adequate space, as opposed to the offices of the public service provider, is appropriate for the meeting.

To the extent possible, participants should include representatives of:

- Service delivery agencies, including managers, engineers, and social development staff (if any).
- Relevant social intermediaries (nongovernmental organizations, community-based organizations), if any.
- Other relevant institutions, for example, schools where improvements to school sanitation are envisaged.
- Other specialist workers in water and sanitation-related functions, such as masons or community health workers involved in hygiene promotion.

Activities

A typical meeting might proceed as follows.

1. **Formal opening**, including self-introduction by the participants.
2. **Introductory icebreaker exercise**. An icebreaker serves to break down hierarchical barriers to interaction and create an informal, relaxed climate conducive to sharing and learning together.
3. **Facilitated discussion** on the key topics on the agenda. It is important that everybody's views are heard and the views of different stakeholder groups recorded.

The stakeholders' meeting is, by virtue of the range of participants, a significant challenge for the facilitator. All efforts must be made to ensure that the hierarchy of institutions is not reflected in the proceedings, that is, the poorer or female participants are not relegated to the background while the community elite and project staff take centre stage. Special care must be taken to ensure equal participation by all. It is advisable to use the services of

professional facilitators adept in the local language. A team of one facilitator and one or two cofacilitators or recorders is preferable.

It is important that the facilitator and recorders are very alert—they should be able to capture the special features of the group dynamics between the different categories of participants and make notes when views differ consistently.

Transect Walk

Purpose

A transect walk can be used to gain an overview of existing water- and sanitation-related facilities in a community from the perspective of the local residents.

Process

During the transect walk, a representative user group of women and men from the local community, together with the facilitators (one of whom should be an engineer), walk from one end of the community to the other. Interactions with residents during the walk yield information about the use, functionality, and adequacy of existing services, as well as financial and institutional arrangements for their operation and maintenance.

The walk should provide an opportunity for observations regarding:

- Water supply sources, in relation to their use for sanitation (flushing, anal cleansing, and personal hygiene).
- Toilet-owning households from different socioeconomic groups.
- Shared and public sanitation facilities.
- Drainage and sewerage systems.
- Locations where wastewater is discharged into drainage channels or natural water courses.
- Areas where wastewater is reused (in this case, further discussion with the users of the wastewater will be beneficial).

It can also be used to cross-check some of the information derived from the community mapping exercise. Key information obtained during the walk should be recorded and should provide an overview of the key needs and challenges in that community.

Appendix B

Costing Technology Options

A preliminary assessment of the cost of a technological option involves an estimation of capital and operation and maintenance costs, and a consideration of the options available for project financing, cost sharing, and revenue generation. The latter is important if operation and maintenance is to be sustained.

At this stage, the costs do not need to be accurate, but it is important to recognize what all the potential costs are, including hidden operational costs associated with staffing and other overheads.

All components of a sanitation system should be considered in the costing, including those relating to off-site sewers and wastewater treatment where applicable. When comparing the costs of different options, it is important to bear in mind that existing facilities represent 'sunk costs', meaning expenditure that has already been made and would be lost if an alternative system was adopted. Two broad approaches can be used to estimate capital and recurrent costs: one for on-site facilities, the other for networked systems.

The cost of on-plot facilities such as household toilets and drains can be calculated using typical house layouts. Normally these costs, and the cost of a sewer connection, are borne by the users unless subsidies are available under a special project or scheme. As such they do not form part of the municipality's costs but have important implications for users in terms of affordability and willingness to pay. For networked systems such as sewerage and drainage, the normal practice is to calculate the capital and recurrent costs of a scheme, and then divide these by the number of households to be served to arrive at an average cost per household for the public or shared components.

Capital Costs of On-Plot Facilities

The costs for individual items may be estimated from either:

1. **Lump sum costs based upon market rates for complete items** (including the cost of labor and the contractors' profit). The simplest approach to estimating the cost of a standard unit (for instance, a pit latrine to be produced to a standard design) is to refer to prices quoted by contractors for previous schemes. This does not, however, provide information on the costs of specific components, hence it can be difficult to adjust the price to allow for price increases or design modifications.
2. **Bill of quantities.** In this case the price is derived based on the combined costs of components, materials, and labor, using local standard rates can be obtained for each unit. This will enable a fuller understanding of the true costs of each technology under consideration and can be used as a benchmark to compare with market prices.

Estimating the Cost of a Networked System

The first step in estimating the cost for a networked system is to establish a hierarchy of components for primary, secondary, and tertiary facilities. The costs of the different components at each level can then be estimated as follows.

Primary and Secondary Facilities

For main drains and collector sewers, the cost can be calculated based on unit costs for pipes of different sizes and the length required for each. Professional assistance is needed for this area of costing.

Costs can be summarized in a table giving the length of each sewer or drain, its size, cost per unit length, and any additional costs required (for example, road reinstatement). For some items—for instance, pumping stations—it will be necessary to make separate allowances for these items. The total cost can then be calculated using these data.

Tertiary Facilities

The cost per hectare of tertiary level facilities (local sewers and drains) can be calculated as follows:

1. Choose areas with housing types and densities typical of the locality.
2. Determine the number of households contained (or potentially contained) within each area.
3. Design a tertiary sewerage and/or drainage system to serve that area, assuming that the system will connect to a secondary facility at the edge of the area.
4. Prepare a bill of quantities using estimates of the cost of materials and labor that would be required for this tertiary system. The cost estimate should exclude house connections, which should be included in household-level estimates.
5. Divide the total calculated cost by the area to provide the average cost per hectare, and by the number of households to give the average cost per household.

This exercise should be carried out for a number of typical areas and the results averaged. The results can be used to estimate the cost of tertiary facilities for all areas with similar characteristics.

Estimation of Recurrent Costs

Recurrent costs are those incurred for the operation and maintenance of facilities, including management overheads. They will vary greatly according to local conditions; for instance, the cost of operating and maintaining a sewer is likely to be much higher in flat areas with poor solid waste management than in an area with good gradients and adequate waste collection services.

Operational, maintenance, and rehabilitation costs should take into account:

- Routine cleaning of drains and waste disposal;
- Purchase of equipment and materials;
- Maintenance of facilities, for instance, public toilets, and so on; and
- Spare parts and replacement costs.

There is often little useful information available on recurrent costs. It may, therefore, be necessary to pilot operation and maintenance procedures in a range of representative areas and to record the costs. The stages in doing this would be to:

1. Select suitable areas large enough to enable meaningful estimates to be made (for example, a whole ward or housing development).
2. Agree on the operation and maintenance procedures to be followed.
3. Implement those procedures over a period of weeks, monitoring the costs, the quality of service provided, and any problems that are encountered.
4. If necessary, make adjustments to operation and maintenance procedures and repeat the exercise to obtain a better idea of the relationship between inputs and the outputs achieved.
5. Extrapolate the results of the exercise to the town as a whole.

Life Cycle Costing

Life cycle costing takes into account capital and recurrent costs and the need to replace infrastructure at the end of its life cycle. A spreadsheet can be developed showing the relevant costs and revenues for each technology over a given time period, and used to help identify the most cost-effective option.

Accounting for Inflation

As financial analysis involves an estimation of the actual amount of money paid and received by the project over a period of time, it is necessary to make adjustments to take into account the impact of inflation on each component where considered to be significant. Differing inflation rates may apply to different components and it should be applied to both expenditures and revenues (but not for capital and interest payments).

Systems that expose the user to high and uncertain levels of operation and maintenance expenditure are risky in an inflationary environment. In general, technologies that have more predictable construction costs or depend less on imports, are less 'risky' with respect to inflation, which may be an important factor in the choice of a system.

Appendix C

Institutional Options for Operation and Maintenance

Table 22 (on page 75) summarizes a range of options for the operation and maintenance of urban sanitation services.

The main areas to consider are:

- Management of household and neighborhood facilities.
- Management of zonal and city-level (primary) infrastructure.
- Managing communication and community liaison.

Operation and maintenance at household level is generally regarded as a household responsibility; municipal involvement is usually confined to the installation of toilets under government programs such as the Integrated Low Cost Sanitation Scheme. However, there may be some services that need external support, not least the desludging of leach pits and septic tanks and disposal of the effluent. It may be necessary both to promote pit emptying and to ensure that an emptying service is available. The municipality, a line department, nongovernmental organizations or private operators could all potentially provide this service.

Some programs have formalized the roles of the community and municipal agencies, based on the level of infrastructure concerned. Typically, households—perhaps via lane or neighborhood committees—are made responsible for ‘internal’ infrastructure and services, meaning local level drains, sewers, waste collection points, water distribution networks, and so on; government agencies retain responsibility for ‘external’ infrastructure and services such as secondary and trunk drains and sewers, bulk water supply lines, and so forth. Maintaining good operational links between municipal and community-managed activities is important.

Where more than one management option appears possible, it is important to consider the capacity of the different sectors. So, for instance, if municipal agencies are short of skills or resources for community liaison, but there are strong community organizations, then community management may be the preferred option at the neighborhood level.

It is also important to consider what *incentives* for good performance would operate under the various management options. There are some areas of service delivery that have been traditionally managed by municipalities or Public Health Engineering Departments, but with very disappointing outcomes—public toilets are a prime example. Contracting out operation and maintenance to informal or private sector operators can result in better quality of service delivery, so long as the service is commercially viable and the contract provides incentives for good performance and imposes penalties where specified standards are not met.

Some additional comments on the various institutional options are provided below.

Municipal Service Delivery

Most municipalities have a large and mostly unskilled sanitation workforce, making it ideal for unskilled and semiskilled labor-intensive tasks such as the maintenance and cleaning of drains and sewers. Some also offer a pit or septic tank emptying service for a fee.

There is often quite limited capacity to provide more complex services such as the operation of treatment plants, especially in smaller municipalities that do not have specialist equipment or staff, though this may be the responsibility of a state agency, typically the Public Health Engineering Departments.

Whatever organizations are involved, the municipality has a central role that it cannot give up: to monitor and enforce standards of service delivery, whether the services are delivered in-house or contracted out. Where monitoring is lacking, service providers can easily avoid their responsibilities and let standards slide.

Nongovernmental Organizations' Involvement

Very often, the added value that such organizations bring to a sanitation program is their ability to work closely with the community: in the initial planning and needs assessment; in capacity building; during the installation of new household facilities; and in operation and maintenance. Managing communication between the municipality and local residents may be central to this role. It is, therefore, important for the municipality to treat nongovernmental organizations not just as private contractors but as partners, especially where community support is central to the success of the new investment. In some cases, it may be better to work with such organizations under a Memorandum of Understanding rather than a contract, so that the organization's independence is not compromised in the eyes of the community.

Where a potential role for nongovernmental organizations has been identified, it should not be assumed that any local organization could fulfil the task or legitimately represent the community. It is important to check whether an organization has the right range of skills for the task, proven experience and the capacity to operate at the scale required. Some nongovernmental organizations are very effective on a small scale but cannot meet the managerial demands of a service once it expands.

It is also important to recognize that, while such organizations have humanitarian objectives, they need to cover their operating costs. They should, therefore, be compensated adequately for any work assigned to them. Continuity is also important; it can be difficult for nongovernmental organizations to continue funding their staff if there are long periods of inactivity between municipal assignments.

Community Management

Community management implies long term community responsibility for a facility or service and in some cases it includes legal ownership of the infrastructure or service. This is usually done through neighborhood groups or other community-based organizations. Community members may carry out the work themselves or play a managerial role and pay a third party, such as a contractor or a community-based organization, to do it for them.

While some initiatives in community management have been successful, rarely can community groups manage services effectively without some level of support from, and coordination with, existing city level management structures. Furthermore, the assumption that poor people have the time and motivation to carry out important tasks on a purely voluntary basis is very misguided, especially in urban settlements that lack the close-knit community structure found in villages. As with private contractors, it is important to consider the financial viability of the service and the incentives for doing the work to a high standard.

Private Sector Participation

Table 22 includes a wide array of options for private sector participation in operation and maintenance, from the provision of specialized, time-bound services to fully independent service provision whereby the private agency develops and delivers a service using its own resources. Generally speaking, the need to harness private sector capacity increases with the complexity of the technology adopted. This is especially true in the case of smaller municipalities without specialist engineering staff. Having said this, the availability of affordable specialist contractors is often limited in smaller towns, reinforcing the case for adopting simple technology as far as possible.

Getting the best out of private sector participation depends on the selection of appropriate contractors and on the effective design and supervision of contracts. Standards of service delivery need to be spelled out clearly and enforced by the municipality.

Multistakeholder Involvement

There can be much to gain from establishing partnerships whereby the municipality, civil society organizations, and private contractors work together towards a common purpose under the umbrella of a partnership agreement. For example, a decentralized wastewater treatment plant might be established on the initiative of the municipality, with government funding, with a nongovernmental organization facilitating community involvement and a private contractor appointed for specialist maintenance tasks.

At their best, partnerships draw on the different strengths of the institutions involved to achieve a comprehensive service delivery package that addresses the full range of service delivery needs: technical, institutional, communication, and so on. The careful assignment of roles and responsibilities within partnerships is important, so that roles match each partner's strengths. A willingness to share not only information but decisionmaking within the partnership is also vital if the partnership is to maximize its potential.

Table 22: Institutional Options for the Construction, Delivery, and Maintenance of Urban Sanitation Services

Title	Description	Applicability	Examples
Municipal service delivery	Direct service provision by municipality's own workforce.	Labor-intensive unskilled and semiskilled tasks, especially, operation and maintenance of secondary and primary infrastructure. However, both capacity and incentives to do a good job may be limited.	Sewer maintenance. Operation of treatment plants. Desludging of septic tanks.
Community or community-based organization involvement			
Community contracting	The community is given responsibility (usually via a community-based organization) for specified construction works and/or maintenance tasks. Community members may execute the work directly or hire others.	Labor-intensive works that do not require very specialized skills. Can be used as a form of capacity-building and income-generating support; also to enhance community ownership of new or improved facilities.	Construction of household toilets. Excavation and laying of shallow sewers.
Community management	Community ownership and control of local facilities (usually via a community-based organization). The community may manage the facilities directly or appoint a third party.	Household and neighborhood facilities that do not require expensive or highly specialized skills for their maintenance.	Operation of public toilet blocks. Emptying of septic tanks?

Title	Description	Applicability	Examples
Nongovernmental organization involvement			
Support to community contracting or management	Nongovernmental organization builds capacity or facilitates community management or contracting; and liaises with the municipal agencies on the community's behalf.	Willingness of municipality to recognize and coordinate with community-managed service.	Construction of on-site facilities. Management of public toilet blocks.
Nongovernmental organization management	Nongovernmental organization manages construction, service delivery and/or maintenance of facilities at local level, possibly within a partnership (see below).	Scope of the nongovernmental organization's role depends on its technical and managerial capacity and skills in community-based approaches.	Construction of on-site facilities. Management of public toilet blocks.
Private sector involvement			
Specialist support to in-house services	Government agency operates sanitation services directly but brings in the private sector, usually for a short period, to fill specific expertise gaps.	Time-bound activities requiring skills and/or equipment that are unavailable within the municipality or line departments.	Use of specialists in no-dig sewer construction.
Service contracts	Government agency is the main service provider but contracts out specific aspects of service delivery (typically two or three years).	Applicable where the municipality lacks the human or financial resources to provide the service directly.	Emptying septic tanks and treatment or disposal of the contents. Provision of IEC, communications.

Title	Description	Applicability	Examples
Management contract—without construction	Experienced operator appointed to take over management of all, or part of, a sanitation service (typically five or seven years).	Municipality has acquired new infrastructure or services but lacks the capacity to manage them in-house; also where local private sector capacity offers added value (such as specialist skills or equipment).	Operation of treatment plant(s). Operation of public toilet blocks.
Management contract—with construction	As above, but includes capital works funded by the public sector (typically five or seven years).	Applicable where construction by management contractor would be more cost-effective than by a municipal agency.	Construction and operation of decentralized wastewater treatment plants, public toilet blocks.
Leasing	Private operator takes complete control of all aspects of a service and controls the revenue stream. Operator pays an annual fee, assets remain in public ownership (usually 12+ years).	There must be scope for significant revenue generation, to incentivize maintenance.	Operation of decentralized sewerage systems, public toilet blocks.
Independent service provision	Local services developed and delivered directly by the informal or private sector using their own resources.	There must be significant local demand for the service.	Construction and operation of private toilet blocks. [Promotion and] construction of household toilets. Emptying of septic tanks and/or transportation and disposal of sludge.

Title	Description	Applicability	Examples
Multistakeholder involvement			
Bi- and tri-sector partnerships	Public, private and/or civil society organizations work within a shared operational framework established by a contract or memorandum of understanding. May include establishment of a service company jointly operated and staffed.	Stakeholders have valuable skills and resources and are willing to work together.	Development of on-site sanitation facilities in low-income communities where community mobilization skills are needed alongside the technical capacity of the private sector.

Appendix D

Technology Data Sheets

On-Site Sanitation

- Pour flush toilet with single leach pit
- Pour flush toilet with double leach pit
- Septic tank
- Communal toilet block

Waste Transportation

- Desludging trucks (Vacutug)
- Conventional sewerage
- Shallow sewerage
- Conventional sewerage

Wastewater and Fecal Sludge Treatment

- Oxidation ditch
- Rotating biological contactors
- Anaerobic baffled reactor
- Reed beds
- Waste stabilization ponds
- Activated sludge process
- Biological trickling filter
- Fluidized aerated bed reactor
- Upflow Anaerobic Sludge Blanket (UASB)
- Upflow anaerobic filter
- Duckweed ponds

Note: For all technologies, the exact capital and operation cost is dependent on type and availability of material, labor, and location. The figure stated is a broad estimate as of 2007.

On-Site Sanitation: Pour Flush Toilet with Single Leach Pit

What is it?

- A technology for on-site disposal of blackwater and storage of excreta for long periods for partial digestion, prior to removal and further treatment. Excreta is flushed into a pit by pouring one or three liters of water. Pour flush toilets have a water seal to reduce odor and insect problems.
- Fecal matter is accumulated in an underground pit normally lined with open-jointed brickwork to enable water to percolate into the ground.
- The pit may be located directly under the latrine superstructure or can be offset so as to enable access for desludging.

Where is it applicable?

- Single leach pits are a simple and relatively inexpensive form of on-site sanitation that have widespread application in urban areas but are dependent upon the provision of an affordable and hygienic fecal sludge collection and treatment service.
- Leach pits are appropriate when water use is at least 25 liters per capita per day. However, they may be used to deal with all household wastewater when per capita water use does not exceed about 50 liters per day, depending upon soil characteristics and groundwater level. If wastewater production is higher, leach pits may still be used for disposal of blackwater with off-site disposal of grey water via a drainage or sewerage system.
- Impermeable soils such as clay or rock preclude the use of leach pits. A high water table may also reduce the capacity of the soil to infiltrate wastewater. In these situations, the pits and latrine superstructure should be raised and a layer of sand provided around the pits to promote infiltration of wastewater.
- Care should be taken when using leach pits in situations where groundwater is used for water supply. A minimum distance of 10 meters should be allowed between a leach pit and a shallow well.

Operation and maintenance requirements

- Once the pit is full, it must be desludged. The methods used should prevent operators or cleaners from coming into contact with fecal material. The undigested and unstabilized sludge must be treated and disposed of safely.

Additional infrastructure or treatment requirements

- Periodically, sludge must be collected and treated prior to reuse or disposal. Collection methods need to be hygienic, preventing contact between workers and feces.

Limitations and risks

- The widespread practice of manual desludging of excreta and its indiscriminate disposal presents a major health risk.
- Pollution of groundwater is likely if the bottom of the pit is less than 2 meters above the groundwater table and people collect drinking water from shallow wells located close to pits. Deeper groundwater may also become contaminated if the underlying ground is fissured rock.
- There are many instances where pits work well initially but problems arise later when water use increases. In this situation, residents often connect their toilets to the surface water drainage system.
- Leach pits are not normally designed to cater for sullage water, nevertheless it is sometimes discharged to pits and can result in overflowing, causing nuisance and a potential health hazard close to houses.

Management arrangements

- Responsibility for maintenance rests primarily with the householder, who will need to pay a private or public service provider to remove the pit contents and transport off-site for treatment and disposal.

How much does it cost?

- *Capital costs:* Varies considerably from Rs 3,500 (US\$85)³ upwards, depending on superstructure construction and ground conditions. Raising the latrine above ground level will increase the construction cost.
- *Operating costs:* Approximately Rs 200–300 (US\$5–7) per year.

Links to other technologies

- Pit emptying and fecal sludge treatment.

Figure 7: Pour Flush Latrine with Offset Single Pit

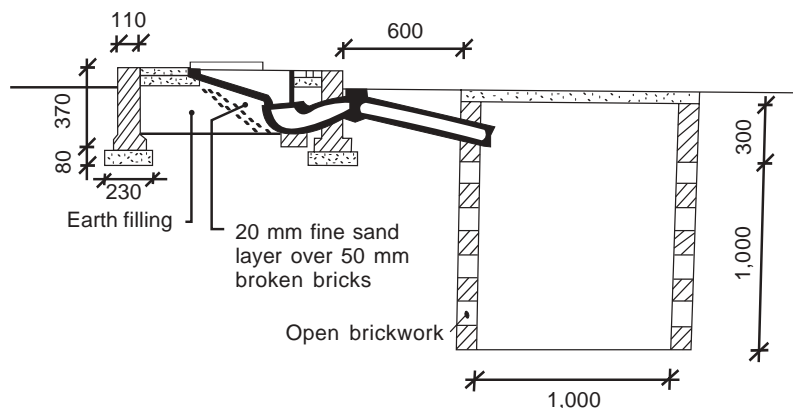

Source: Cairncross, Sandy, and Richard Feachem. Environmental Health Engineering in the Tropics: An Introductory Text.

³ US\$1 = INR 41 (approximately, as of October 2007). Conversion rates are from <https://www.cia.gov/library/publications/the-world-factbook/fields/2076.html>; all conversions in the text are approximations.

On-Site Sanitation: Pour Flush Toilet with Double Leach Pit

What is it?

- A technology for on-site disposal of blackwater while storing fecal material for a period long enough for digestion to render it harmless. Digested sludge can be used as a fertilizer or soil conditioner without further treatment.
- Two underground chambers are provided to hold fecal matter. These are normally offset from the toilet and should be at least 1 meter apart. A single pipe leads from the toilet to a small diversion chamber, from which separate pipes lead to the two underground chambers. The pits should be lined with open-jointed brickwork, similar to the single pit design. Each pit should be designed to hold at least 12 months' accumulation of fecal sludge.
- Blackwater is discharged to one chamber until it is full of fecal sludge. Discharge is then switched to the second chamber. Just before the second chamber is full of fecal sludge, the contents of the first pit are dug out. During the time of storage, digestion should ensure that it is odorless and free of pathogens.

Where is it applicable?

- In low- to medium-density areas, particularly periurban areas, where there is space on or immediately outside the plot to install the pits and where the digested sludge can be applied to local fields and/or gardens as a fertilizer and soil conditioner. This technology has been widely used in the Government of India's Integrated Low Cost Sanitation Scheme (ILCS).
- Where water use is in the range 30–50 liters per capita per day depending upon the characteristics of the soil or groundwater level.
- Where the depth to the water table is 3 meters or more, allowing a clear 2-meter vertical distance between the bottom of the pit and the water table.
- Constraints for single leach pits relating to impermeable soils and the proximity of wells and tubewells also apply to double leach pits.

Operation and maintenance requirements

- The pits must be used alternately and the diversion chamber must be accessible so that flow can be diverted between chambers.
- Wastewater should never be diverted back to the first chamber before digested sludge has been removed from it.

Additional infrastructure or treatment requirements

- If digested material cannot be used in local fields and gardens, provision will have to be made for transportation to areas outside the city for reuse on agricultural land.

Limitations and risks

- Householders may not understand the system and as a result may not use the pits alternately, or may omit to rest the filled pit at least for one year so that the contents degrade and become harmless. Explanation of the operation and maintenance requirements is therefore essential at the time of installation.
- Water may percolate through the soil surrounding the pit and pollute groundwater, which is a potential problem if water is used for drinking.

Management arrangements

Responsibility for operation and maintenance rests primarily with the householder, who needs to ensure that the pits are used in the correct sequence and are emptied at the appropriate time.

How much does it cost?

- *Capital costs:* Varies, depending on superstructure construction details and the ease of digging, but the minimum cost of the standard Integrated Low Cost Sanitation Scheme design is Rs 5,000 (US\$120).
- *Operating costs:* Roughly, Rs 200–300 (US\$5–7) per year.

Figure 8: Pour Flush Latrine with Offset Twin Pit

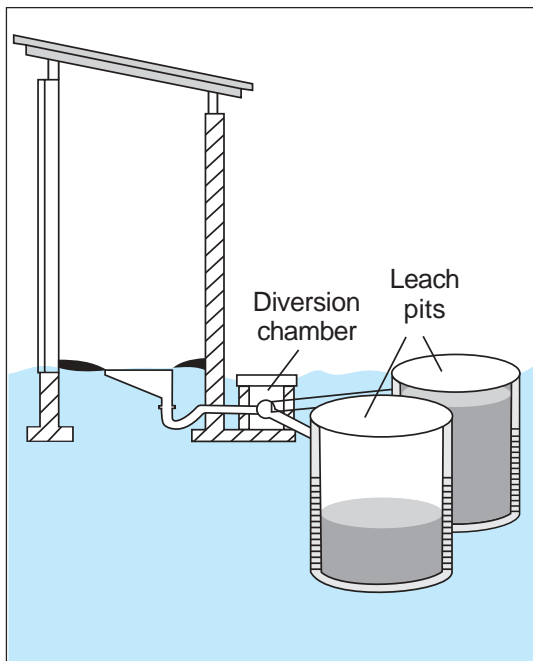

Source: WHO 2003. Reproduced with permission from the World Health Organization, Geneva.

On-Site Sanitation: Septic Tank

What is it?

- A septic tank is a buried chamber that collects and stores domestic wastewater (usually both blackwater and sullage) and treats organic waste under anaerobic conditions.
- Effluent from septic tanks should be discharged to an on-site infiltration system (soakaway or drain field) or a small-bore sewerage system, or be treated on-site before discharge into surface water. In practice, many septic tanks discharge pathogenic effluent directly into open drains, posing a public health risk.
- The standard septic tank design incorporates two chambers. Some septic tank designs adopted in India have three chambers. Most of the treatment takes place in the first chamber.
- A well-managed septic tank will remove about 50–60 percent of the biological load in the wastewater.

Where is it applicable?

- Septic tanks are widely used to provide partial treatment of wastewater from individual homes, clusters of houses or institutional buildings where there is no sewerage network.
- Appropriate in periurban settlements or less dense urban areas due to the fact that they do not require any centralized infrastructure.
- Normally associated with *pucca* [permanent] houses for middle and higher income households.
- For soakaways to function, soil conditions must be suitable for infiltration of effluent from septic tanks. A microwetland can help through increased evapo-transpiration losses and moisture uptake. Sullage must not be discharged into a septic tank.

Mode of operation

- Solids settle in the tank and digest anaerobically. This reduces sludge volume and enables wastewater to infiltrate into the ground without clogging the leaching system.
- Sludge settles in the tank and digests anaerobically over time, releasing methane and other gases.

Operation and maintenance requirements

- Septage must be removed from septic tanks and transported off-site for treatment prior to disposal.

Additional infrastructure

- Septic tank desludging.
- Septage treatment.

Limitations and risks

- The biggest disadvantages of septic tanks are the cost and space requirements for the soakaway or drain field. The leaching system is often not constructed and common practice is to discharge effluent directly into an open drain.
- Septic tanks often receive too much wastewater. As a result, the retention time in the septic tank is insufficient and the soakaway becomes hydraulically overloaded. This means that the septic tanks needs to be desludged regularly, but more commonly the householder bypasses the soakaway and connects the overflow directly to a surface water drain.
- Shock loadings and disturbance of settling zones caused by large inflows (typically from sullage discharges) can affect the efficiency of the septic tank and cause excess solids to flow into the soakaway.
- Performance monitoring of septic tanks is rarely undertaken and regulation to control private desludging operators is problematic.

Management arrangements

- Responsibility for operation and maintenance lies with the owner of the property.
- Municipal utility or private contractors are required for desludging of septic tanks and to ensure safe disposal of septage at a treatment plant.

How much does it cost?

- *Capital costs:* A conventional septic tank constructed from brick or concrete is a considerable household investment, but cheaper options are available, made from prefabricated plastic or concrete rings. Costs range from Rs 6,000–15,000 (US\$140–360).
- *Operating costs:* Varies from Rs 500–1,500 (US\$12–37) once every few years depending on the frequency of emptying, size of tank and distance to treatment plant.

Figure 9: Pour Flush Latrine with Septic Tank and Soakaway

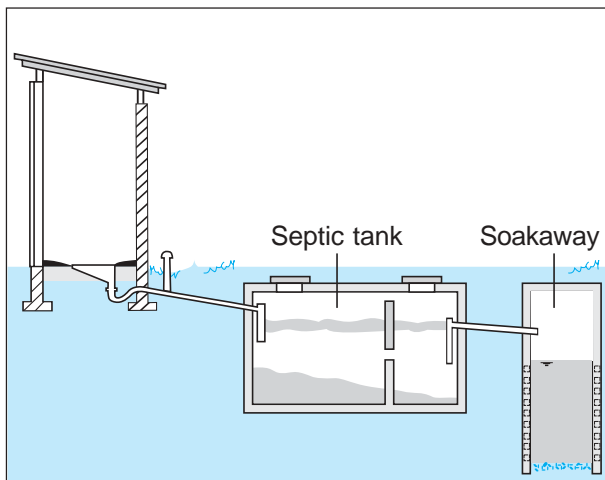

Source: WHO 2003. Reproduced with permission from the World Health Organization, Geneva.

On-Site Sanitation: Communal Toilet Block

What is it?

- A communal toilet block is a shared facility provided for a group of residents or an entire settlement. Pour flush technology is generally used though dry ‘ecological sanitation’ (ecosan) toilet blocks have been piloted in a few locations. Washing facilities are sometimes included in the block.

Where is it applicable?

There are two situations where a communal toilet block is appropriate:

- Communal toilet blocks are used primarily in low-income informal and illegal settlements where house connections are too expensive or nonviable due to a lack of space and/or land tenure problems.
- Public toilet blocks are provided for occasional use by the general public in places such as markets, train stations or other public areas where there is a considerable number of people passing by.

Operation and maintenance requirements

- Operation and maintenance requirements depend upon the technology adopted: (a) If the facility discharges into a sewer, then the operation and maintenance requirements will primarily concern keeping the toilet block clean; and (b) If the toilet block has on-site wastewater collection and treatment then the operation and maintenance burden (including desludging) will be higher.

Additional infrastructure or treatment requirements

- Toilets blocks either discharge to a sewer or into a septic tank—potentially with additional on-site treatment depending on the discharge or reuse requirements.

Limitations and risks

- The main risk is that the municipality (or contracted operator) does not maintain the block adequately so that it becomes unsanitary and falls into disuse.
- People may be deterred by the user charge and the facility is underused.
- Reliable water and electricity supplies are essential, but not always available.
- Women and children may not use the facility if they consider it unsafe to go there.

Management arrangements

- A range of management options are possible depending upon whether the toilet block is communal or public. Communal blocks are commonly managed by the municipality, a nongovernment organization (NGO) or a community-based organization with NGO support.

How much does it cost?

- *Capital costs:* Depends on many factors such as location, waste disposal arrangement, contract duration, and so on. The initial investment cost can be in the range of Rs 800,000 (US\$19,500).
- *Operating costs:* Also varies depending on size, location, and so on, but can be more than Rs 200,000 (US\$4,000) per annum.

Examples

- Sulabh International pioneered the nongovernment organization-managed toilet block in India and operates facilities in many cities.
- CBOs and NGOs such as SPARC and Shelter Associates have promoted community management of toilet blocks in Mumbai and Pune. The approach adopted by SPARC was incorporated into a World Bank-funded project in Mumbai. Under this program the typical per seat cost was Rs 80,000 (US\$2,000) and the toilet block included water supply, overhead tank, electricity, septic tank, and a caretaker's room.
- BORDA and its nongovernment organization partners (including FEDINA, EXNORA) have promoted community managed toilet blocks in Bangalore and other cities. These are successfully managed by community-based organizations but require ongoing support to help with technical issues, especially where there is on-site treatment.
- In New Delhi, the municipal bodies have piloted the involvement of private entrepreneurs via Build, Operate, and Transfer contracts. A novel feature of the contracts is that the operators are allowed to use the road-facing walls of the premises as advertising space. This enables them to generate substantial revenues.

Figure 10: Community Toilet Block

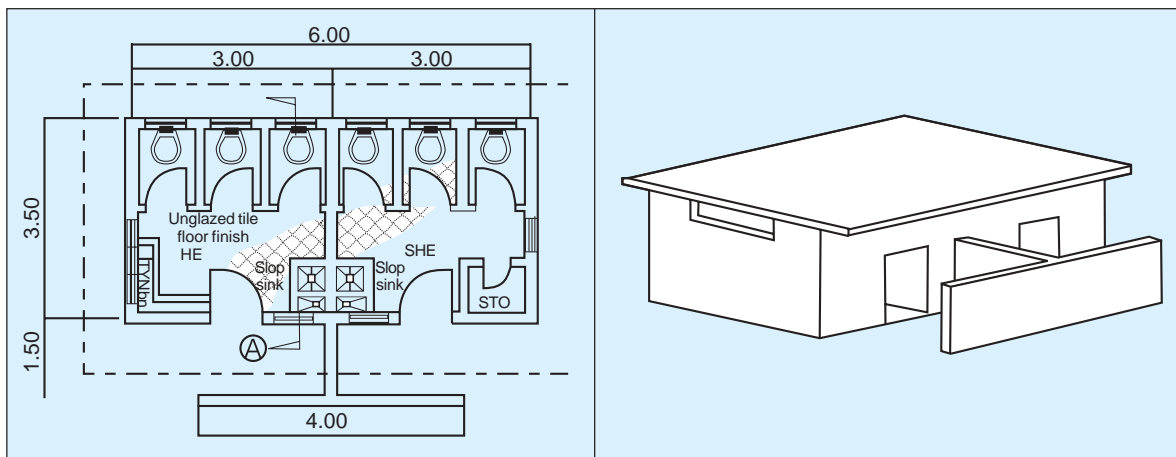

Source: Philippines Sanitation Sourcebook and Decision Aid, WSP-EAP.

Waste Transportation: Desludging Vehicle (Vacutug)

What is it?

- The Vacutug is a device for emptying pit latrines and leach pits with a vacuum pump discharging into a 500-liter tank fitted onto a wheelbase with a small engine for driving it around.
- A modified system (known as Vacutug Mark II) developed in Dhaka, Bangladesh, has a larger capacity tank on a trailer which is pulled by a vehicle.

Where is it applicable?

- Can be used in high-density informal settlements with narrow lanes where conventional vacuum trucks are unavailable or vehicular access is difficult.
- Used for cartage of fecal sludge over a short distance (maximum 1 km for Mark I and 5 km for Mark II) from the point of collection to a treatment facility, municipal sewer or an intermediate collection point, from which waste can be collected using larger conventional sludge trucks.

Mode of operation

- A small diameter hose is inserted into the pit and used for evacuating the excreta under vacuum pressure, which is generated by a motor located on the chassis of the Vacutug.
- Pits frequently require the addition of water to loosen compacted solids that have consolidated over time.
- After motoring to the discharge point, the Vacutug tank is emptied by gravity or under pressure if the waste needs to be lifted up to an elevated storage tank.

Operation and maintenance requirements

- Two trained operators can operate the Vacutug under supervision and can be responsible for cleaning and maintaining the machine, emptying the pits, driving the machine to the disposal point, and carrying out minor repairs.
- The operators should be warned about the hazardous nature of latrine wastes and should be provided with rubber boots, rubber gloves, overalls, and disinfectant soap.
- The Vacutug is designed to be operated and maintained with a minimum of servicing and spare parts, but some preventative servicing will ensure its optimum life and operational performance. Maintenance requires one part-time mechanic for a weekly check-up and when it breaks down.

Additional infrastructure or treatment requirements

- Collected sludge needs to be discharged into a treatment facility or sewerage system. Alternatively, the waste can be stored temporarily prior to transportation to a larger sludge processing facility.

Limitations and risks

- Regulation of operators is important to prevent dumping of fecal sludge into local drainage channels.
- The suction pump may not be powerful enough to raise hardened sludge from a deep (>2 m) latrine.
- Solid waste in the pits can block and tear the suction pipe.
- The system is only financially viable if users are prepared to pay emptying charges, which may be higher than those of informal contractors using unsanitary methods.

Management arrangements

- Small-scale desludging operations using the Vacutug can be managed by nongovernmental organizations or small private entrepreneurs working in low-income settlements.

How much does it cost?

- *Capital costs:* Varies considerably depending on the use of imported or locally-manufactured equipment.
- *Operating costs:* Varies depending on the need to import spare parts.

Links to other technologies

- Fecal sludge treatment.

Examples of application

- Sulabh International Social Service Organisation, India.

Sources of further information

- UN-HABITAT Operating and Maintenance Manual for Mark II Vacutug Latrine Emptying Vehicle. UN-HABITAT/United Nations Human Settlement Program, Nairobi.
- Alabaster, G., and I. Issaias. 2003. 'Removing Human Waste: The Vacutug Solution. Habitat Debate, Case Studies'. September 2003, Vol 9 (No 3). UN-HABITAT, Nairobi.

Figure 11: A Vacutug

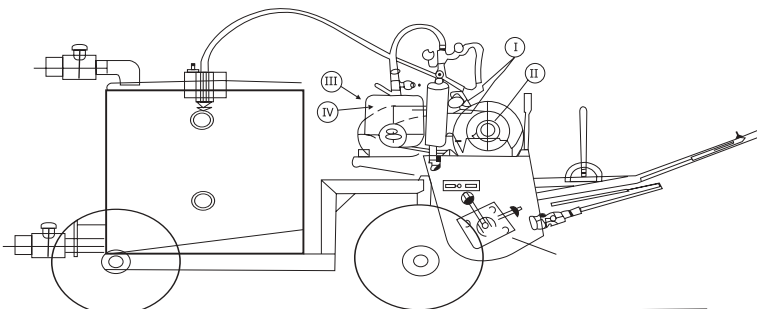

Source: Reproduced with permission from UN-HABITAT, Nairobi.

Wastewater Transportation: Conventional Sewerage

What is it?

- Conventional sewerage consists of a closed system of pipes, manholes, and pumping stations (in flat areas), which takes wastewater from domestic and other properties to disposal or treatment facilities.

Where is it applicable?

- Conventional sewerage is used extensively in urban areas to dispose of wastewater from residential, commercial, and industrial areas.

Operation and maintenance requirements

- Sewers and manhole chambers will occasionally require structural repair or replacement, and broken and missing manhole covers should be replaced immediately.
- In gravity sewers, wastewater and solids are flushed along the sewer line to a treatment plant. If sewers are laid to self-cleansing velocities, they should require little routine maintenance. However, silting can be a problem where falls are limited and/or storm run-off carrying silt enters sewers. In such situations, periodic rodding, flushing or jetting will be required to remove blockages.
- Where pumping is required, considerably more attention will be required to operate and maintain pumps and other associated electro-mechanical equipment.

Additional infrastructure or treatment requirements

- Requires off-site wastewater treatment.

Limitations and risks

- Operation and maintenance costs can be high, especially where pumping is required or silt and other solids cannot effectively be excluded from the sewer. As a result, many service providers rely upon subsidies to keep the system functional.
- Sewers often become heavily silted and lose hydraulic capacity or become completely blocked.
- Illegal storm water collections may lead to hydraulic overload of the sewerage system during heavy rainfall events. This may result in the flow of runoff contaminated with excreta flowing in streets and sometimes houses.
- In order to save electricity costs, pumping station operators often maintain wastewater levels in the wet well above the invert level of the incoming sewer. This reduces flow velocities in the incoming sewer and leads to rapid siltation.
- In many cases a sewerage system is built in isolation from the sewage treatment plant and the two do not connect.
- Households may not connect their facilities to the sewer network due to high connection charges and low willingness to pay.

Wastewater Transportation: Shallow Sewerage

What is it?

- Developed for use in residential areas, these sewers can be laid at relatively shallow depths due to the absence of heavy traffic.
- A simplified design and layout is used with inspection chambers instead of manholes. This reduces construction costs, facilitates cleaning, and makes it easier and cheaper to connect households to the system.

Where is it applicable?

- Particularly appropriate for dense informal settlements where laying sewer lines is often problematic due to the unplanned, irregular layout of buildings and streets.
- Can also be used in higher income residential areas to reduce installation costs.
- Can be supported by a decentralized sewage treatment facility.

Operation and maintenance requirements

- Shallow sewerage may require occasional flushing to remove blockages, but no more so than conventional sewers unless they are laid to flatter gradients.
- Sewers and inspection chambers will occasionally require structural repair or replacement.

Additional infrastructure or treatment requirements

- Requires off-site wastewater treatment.

Limitations and risks

- Can be problematic to install through private properties requiring considerable efforts to work with local communities. Residents need to be motivated to connect to the system and to maintain the private component.
- Communities often need support from the public agency to deal with blockages. Such problems can be aggravated in communities with a changing population, since new residents may be unaware or unwilling to take on their operation and maintenance responsibilities.

Management arrangements

- The network may be managed by a centralized service or, alternatively, can be divided into private (house connections and lane sewers) and public (collector and main sewers) components. Users can be made responsible for maintaining lane sewers, while the public service provider remains responsible for the main sewers. The users may employ the services of a private operator or form a cooperative.

How much does it cost?

- The technology is cheaper than conventional sewerage. Cost reductions stem mainly from:
 - Lower excavation volumes.
 - Use of simplified inspection chambers instead of costly manholes.
 - Reduced pipe diameters and layout length.
- *Capital costs*: Approximately Rs 50,000/m³/day flow (US\$1,200). Low to medium investment costs if population density is high, number of connections is large, and three to four households share one connection.
- *Operating costs*: Rs 215/m³ (US\$5) or Rs 1,800/m (US\$40) of pipeline based on regular cleaning of the system, sewer line and inspection.

Examples of practical experience

- The Ramagundam municipality in Andhra Pradesh has also adopted this technology for slum sanitation to good effect.
- Shallow sewerage (also known as ‘condominial’ sewerage) has been used extensively in Brazil since the 1980s in both high- and low-income residential areas. More recently, the technology has been piloted in Bolivia, Peru, and South Africa.

Sources of further information

- CPHEEO. 1993. *Manual on Sewerage and Sewage Treatment of the Central Public Health and Environmental Engineering Organization*. Ministry of Urban Development.
- Water and Sanitation Program. 2005. *The Experience of Condominial Water and Sewerage Systems in Brazil*. Washington D. C.

Wastewater Transportation: Small-Bore Sewerage

Otherwise known as Septic Tank Effluent Disposal Scheme (STEDS) or Sewered Inceptor Tank Systems (SITS)

What is it?

- A hybrid system comprising interceptor tanks connected to small-diameter sewers for drainage of domestic wastewater. Removal of solids in the interceptor tanks means that sewers carry only liquid and so can be of smaller diameter, and laid to flatter gradients, than conventional sewerage.

Where is it applicable?

- Appropriate where wastewater production is at least 25 lpcd.
- Lower gradients result in reduced excavation depths where topography is flat. So, small-bore sewerage may be a good option in flat areas, particularly where the water table is near the surface.
- Can provide a cost-effective way to upgrade septic tanks to a level of service comparable with conventional sewers.
- Can be used where effluent from pour flush toilets and household sullage cannot be disposed of on-site due to soil and/or groundwater conditions, but there is insufficient water to allow for operation of conventional sewerage.

Mode of operation

- Solids settle in the bottom of the tanks and partial anaerobic degradation of wastewater occurs. The supernatant liquid is discharged into the sewer, together with finely divided digested solids.

Operation and maintenance requirements

- Interceptor tanks need periodical desludging and disposal of solids.

Additional infrastructure or treatment requirements

- The effluent from interceptor tanks transported through small-bore sewerage can be discharged into conventional sewerage or treated locally in a decentralized wastewater treatment plant.

Limitations and risks

- Small-bore sewerage systems may have the same operational and maintenance problems associated with both septic tanks combined with the need for maintenance of the sewers. This situation is exacerbated where the ownership and roles and responsibilities for operation and maintenance are not well defined or not accepted.

Management arrangements

- Individual households are normally responsible for maintenance of each interceptor tank (as with septic tanks) while the sewer network requires a communal management arrangement. This may involve a central service provider or small private operator employed to maintain the system and clean the tanks regularly.

How much does it cost?

- *Capital costs:* Considerably lower than for conventional systems. Approximately Rs 28,100 (US\$685) for the unit illustrated. Desludging costs roughly Rs 2,500 (US\$60) every five years.
- *Operating costs:* Depends on topography. Reduced pumping costs due to reduced depth must be balanced against cost of periodic removal of sludge from tanks.

Links to other technologies

- Desludging of fecal sludge.

Examples of practical experience

- Sewered Interceptor Tank Systems (SITS) have been used successfully in Australia; there are also examples in Pakistan, South Africa, and the Maldives.

Sources of further information

- Otis, R. J., and D. D. Mara. 1985. *Design of Small Bore Sewerage Systems*. Series TAG Technical Note #14. The World Bank, Washington D. C. Sanicon website at www.sanicon.net/titles/topicintro.php3?topicId=8. Website www-wds.worldbank.org

Figure 12: Small Bore Sewerage

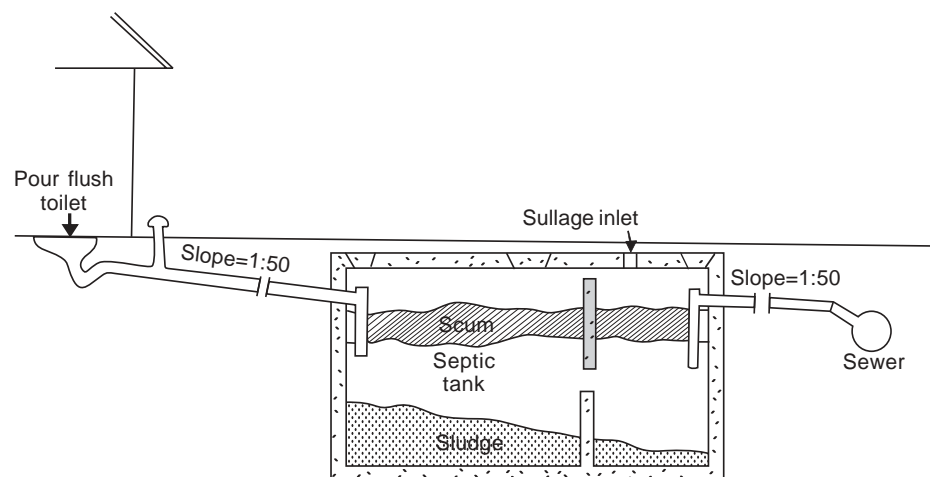

Source: After Kalbermatten et al. 1982.

Wastewater Treatment: Oxidation Ditch

What is it?

- An activated sludge treatment process with a long solids retention time to improve the efficiency of pollutant removal.
- Typically consists of a single or multichannel configuration within a ring-, oval- or horseshoe-shaped basin.
- Horizontally or vertically mounted aerators ensure that the wastewater is oxygenated and promote a circular flow of wastewater through the channel.

Where is it applicable?

- Most appropriate for treatment of intermittent flows from small communities and isolated institutions where there is sufficient land for installation.

Mode of operation

- Long hydraulic retention time and complete mixing reduces the impact of shock loads or hydraulic surges.
- Produces less sludge than other aerobic treatment processes due to long solids retention times and extended biological activity.

Operation and maintenance requirements

- Needs a skilled wastewater engineer and electro-mechanic technician to keep the treatment plant working efficiently.
- Sludge tends to have high water content but is relatively easy to dewater and smaller in volume than sludge from conventional activated sludge plants.
- Total power costs are higher than for conventional activated sludge due to the extended retention time.

Additional infrastructure or treatment requirements

- May be preceded by a primary sedimentation tank but many systems omit primary sedimentation.
- Excess biomass is removed in a clarifier and some is returned to the oxidation ditch to maintain sufficient concentration of active biomass in the reactor. The excess sludge collected by the clarifier must be dewatered and treated before disposal.

Limitations and risks

- Effluent suspended solids' concentrations are relatively high compared to other modifications of the activated sludge process.
- Power requirement is higher than for conventional activated sludge processes-leading to high power costs and the need for a reliable power supply.

Management arrangements

- Oxidation ditches are simpler to operate than activated sludge plants but are considerably more complex than waste stabilization ponds.

How much does it cost?

Plant capacity (m ³ /day)	Capital costs (in US\$)*	Annual O&M costs (in US\$)
200	419,400	4,900
600	777,200	6,900
2,000	1,470,500	10,300

*US\$1 = INR 41 (approximately, as of October 2007). Conversion rates are from <https://www.cia.gov/library/publications/the-world-factbook/fields/2076.html>; all conversions in the text are approximations.

Figure 13: Oxidation Ditch

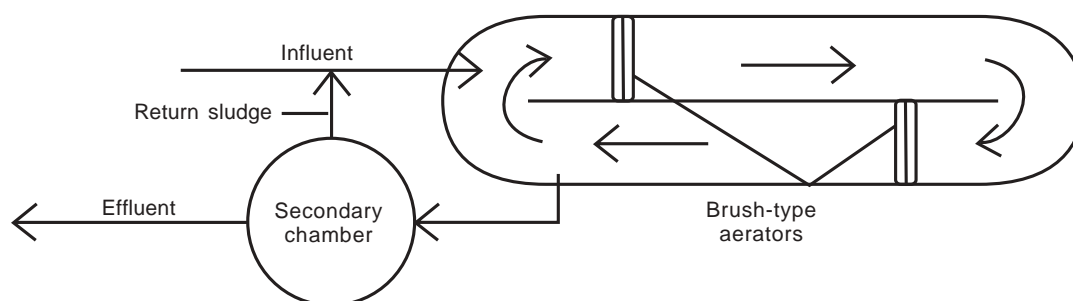

Source: Photo is from Philippines Sanitation Sourcebook and Decision Aid, WSP-EAP.

Wastewater Treatment: Rotating Biological Contactor

What is it?

- A rotating biological contactor consists of a series of discs which are partially immersed in the wastewater and rotate slowly to allow active bacteria to digest dissolved organic wastes.

Where is it applicable?

- This technology is most effective for small communities and isolated institutions where there is enough land for installation. However, due to operational and maintenance problems (see below), it is not generally recommended for use in India.
- Domestic sewage, effluents, and process wastewater from dairies, bakeries, food processors, pulp and paper mills, and other biodegradable industrial discharges can be treated by the process.

Mode of operation

- As the discs rotate, a film of biomass grows on their surface, comes into contact with the wastewater and treats biodegradable organic matter. Atmospheric oxygen is supplied to the bacteria in the biofilm when the discs are out of the wastewater.
- Excess biomass sloughs off the discs by the shearing forces exerted as the discs rotate combined with the force of gravity.
- Advantages of rotating biological contactor technology include:
 - A higher level of treatment than conventional high-rate trickling filters due to a longer contact time (8 to 10 times greater); and
 - Reduced susceptibility to changes in hydraulic or organic loading than the conventional activated sludge process.
- The rotating biological contactor process can be designed to remove 80–90 percent of the biochemical oxygen demand (BOD) but full nitrification can only be achieved when the organic loading rate is less than 5 g BOD/m²/day.

Operation and maintenance

On a daily basis, there is little need for operation and maintenance, but there can be problems with breakage of the shaft and the mechanism that turns the discs.

Additional treatment requirements

- Raw municipal wastewater should not be applied to a rotating biological contactor. Primary settling tanks are required for removal of grit, debris, and excessive oil or grease prior to the rotating biological contactor process. In some cases, fine screens (0.03–0.06 inches) may be installed.
- Excess biomass is removed in a clarifier that follows the rotating biological contactor. It then requires sludge treatment.

Limitations and risks

- As the motor is dependent upon electricity, the rotating biological contactor is prone to failure as a result of power cuts.
- The shaft, discs, and motor all require maintenance.

Management arrangements

- A self-enclosed system with few day-to-day management arrangements. However, the system's reliance on mechanical parts means that skilled personnel are required for maintenance and repair.

How much does it cost?

- *Capital costs:* Rs 3.36 million (US\$81,000) per MLD capacity.
- *Operating costs:* High operating costs, in the region of Rs 14,000 (US\$340) per month.

Figure 14: Rotating Biological Contactor

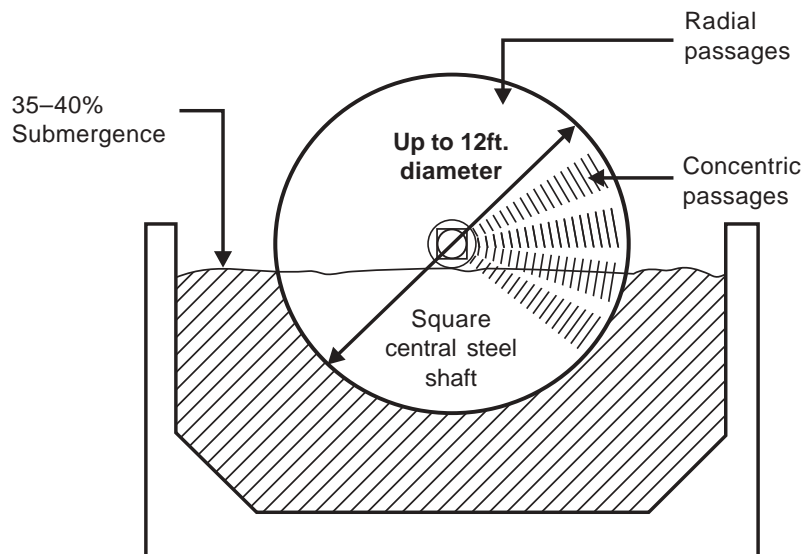

Source: Philippines Sanitation Sourcebook and Decision Aid, WSP-EAP.

Wastewater Treatment: Anaerobic Baffled Reactor

Otherwise known as Baffled Septic Tanks.

What is it?

- An anaerobic baffled reactor consists of a settling compartment with the same dimensions as the first compartment of a conventional septic tank, followed by a number of smaller compartments arranged in series.
- After passing through the first compartment, sewage passes from bottom to top through the remaining compartments in turn. Intensive contact between resident sludge and incoming liquid increases treatment efficiency.

Where is it applicable?

- The baffled reactor tank is suitable for all kinds of wastewaters (including domestic) but its efficiency increases with higher organic loadings and is therefore most appropriate for the treatment of blackwater.
- Suitable for small community schemes and housing developments with no access to municipal sewerage.

Mode of operation

- Baffled reactors involve a combination of physical treatment and anaerobic digestion as the incoming wastewater passes through a blanket of suspended flocculations of active bacterial sludge in each compartment.
- Wastewater flows from bottom to top with the effect that sludge particles settle against the upstream flow of liquid. Digestion of substances that are difficult to degrade takes place in the upward flow baffled reactors after more easily degradable material has been digested in the front chamber.
- Treatment performance depends on the availability of active bacterial mass but is normally 65 percent COD (70 percent BOD) removal.

Operation and maintenance

- Adequate arrangements must be made for periodic removal of sludge from the first compartment. Sludge accumulation in the baffled compartments should be much less.
- Although desludging at regular intervals is necessary, it is important that some active sludge is left in each of the compartments to maintain a stable treatment process.

Additional treatment requirements

- The last chamber may consist of an anaerobic filter to improve treatment performance.
- A reed bed or maturation pond for posttreatment is necessary to eliminate septicity and increase dissolved oxygen level before releasing into surface water or using for irrigation.

Limitations and risks

- Operation and maintenance is easily ignored, leading to deterioration in performance.

Management arrangements

- The system is fairly robust and relatively easy to operate but nevertheless requires organized technical management.

How much does it cost?

- *Capital costs:* Rs 750,000 (US\$18,200) for a 14,000 liter/day plant.
- *Operating costs:* Rs 12,000 (US\$300) per annum for a 14,000 liter/day plant, equivalent to Rs 0.86/liter/day (US\$0.02/liter/day)

Sources of further information

Sasse, L. 1998. *DEWATS: Decentralized Wastewater Treatment Systems in Developing Countries*. Bremen Overseas Research and Development Association, (BORDA), Bremen, Germany.

Figure 15: Anaerobic Baffled Reactor

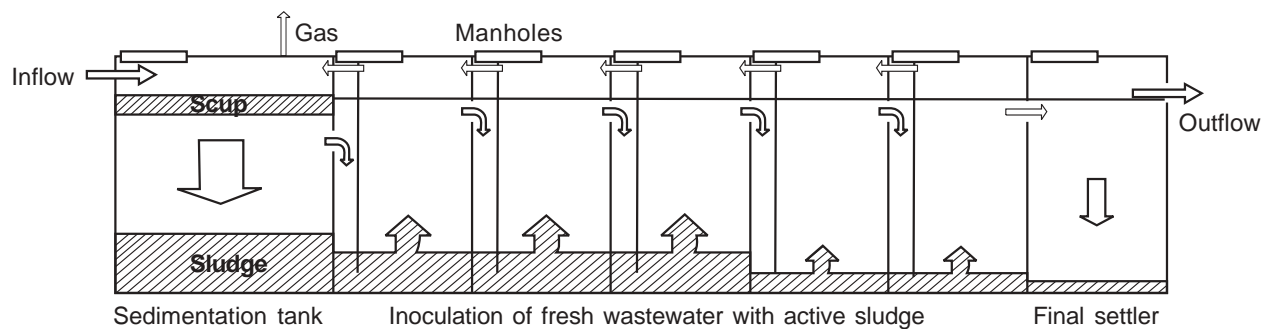

Source: Philippines Sanitation Sourcebook and Decision Aid, WSP-EAP.

Wastewater Treatment: Reed Beds

Also known as constructed wetlands, planted horizontal gravel filters, subsurface flow wetlands or root zone treatment.

What are they?

- Reed beds are engineered natural treatment systems that use fast growing plant species to assimilate dissolved organic impurities. A combination of physical settlement, photosynthesis, uptake by plants, degradation by bacteria in the root-zone, and filtration bring about improvement in wastewater quality.
- There are various types of reed beds for different treatment applications. Horizontal sub-surface flow systems are most appropriate for domestic wastewater treatment whereas vertical flow is used for dewatering of sludge and treatment of septage.
- Reeds are planted in the media. Commonly used plants are cattails, bulrushes and reeds, with *Phragmites australis* being ideal due to its extensive root system.

Where are they applicable?

- Reed beds provide secondary and tertiary treatment and can treat a wide range of wastewaters, septage, and fecal sludges of varying strengths and composition.
- They are suitable for pretreated (presettled) domestic or industrial wastewater with a COD content less than 150–200 mg/l (BOD 70–90 mg/l) and are generally good at handling intermittent and variable flows.
- The most common use is to provide additional or advanced treatment of wastewater from homes, businesses, and small communities. The technology is also well-suited for hotels, campsites, resorts, and recreational areas.

Mode of operation

- Reed beds mimic the treatment that occurs in natural wetlands by relying on plants and a combination of naturally occurring biological, chemical, and physical processes to remove pollutants from the water.
- Treatment is mostly anaerobic as the layers of media and soil remain saturated and unexposed to the atmosphere.
- The main role of the plants is to transport oxygen via their roots into the filter media though the roots also reduce clogging of the filter.

Operation and maintenance requirements

- Operation and maintenance requirements are simple but essential to ensure system performance. They include removal of excess weed, occasional scraping of the top layer of filter media, and removal of the floating scum layer, plastic and other debris.
- Insect and odor problems should not be a problem as long as the wastewater remains under the gravel and sand. Otherwise, insecticide spray should be used to control mosquitoes and other insects.
- Inlet and outlet structures should be cleaned periodically. The filter media will eventually become clogged and should be changed every 8 to 15 years.
- Plants need to be harvested.

Additional treatment requirements

- To prevent clogging of the media, wastewater must be pretreated to reduce suspended solids. For this reason, reed beds are best used for secondary treatment following primary treatment in a sedimentation tank, septic tank, baffled reactor or other form of anaerobic treatment.
- Sludge production is relatively low as solids are retained in or on the reed bed.

Limitations and risks

- Careful design is required to ensure that the filter media is of appropriate grain size and quality.
- Reed beds require a large amount of space, up to 5 m² per person, depending on conditions, and are therefore not always appropriate in urban areas.
- Odor caused by ponding on the surface, blockages in inlet pipe work and problems with drainage at the outlet can result in the development of septic conditions in the reed bed.
- A blocked or overloaded reed bed can cause the wastewater to rise above the surface, which may result in problems with mosquitoes or other insects.

Management arrangements

- Although the process is natural, constructed wetlands are complex systems that require specialist knowledge and technical expertise to ensure sustained performance.

How much do they cost?

- *Capital costs:* Estimated cost at Rs 1,300/m² (US\$30/m²) for horizontal flow beds and Rs 2,100/m² (US\$50/m²) for vertical flow beds, excluding land cost.
- *Operating costs:* Consists mainly of labor costs for reed cutting at intervals of three or four years.

Sources of further information

- Sasse, L. 1998. *DEWATS: Decentralized Wastewater Treatment Systems in Developing Countries*. Bremen Overseas Research and Development Association (BORDA), Bremen, Germany.
- US-EPA. 2000. *Manual Constructed Wetlands Treatment of Municipal Wastewaters*. Report EPA/625/R-99/010. United States Environmental Protection Agency, Office of Research and Development, Cincinnati, Ohio 45268.

Figure 16: Wastewater Treatment Process

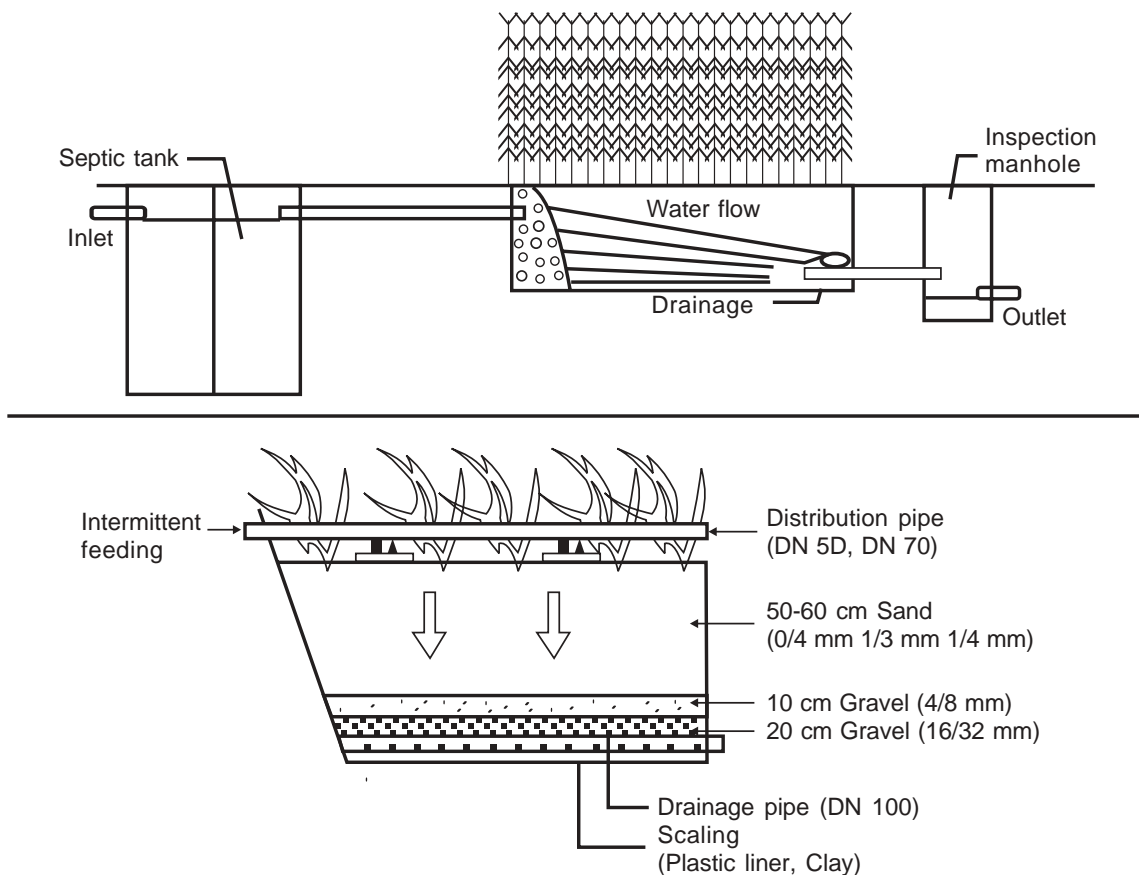

Source: Philippines Sanitation Sourcebook and Decision Aid, WSP-EAP.

Wastewater and Fecal Sludge Treatment: Waste Stabilization Ponds

What are they?

There are three basic types of waste stabilization ponds and these are normally connected in series to provide a two- or three-stage treatment process. They are:

- **Anaerobic ponds:** Comparatively small and deep (3–4 m) as there is no need for aeration. They receive raw sewage which is treated by anaerobic bacteria, while sludge that builds up in the bottom of the pond is digested by anaerobic micro-organisms.
- **Facultative ponds:** Shallower (1.5–2 m) with a larger surface area than anaerobic ponds. They consist of an aerobic zone close to the surface and a deeper, anaerobic zone.
- **Maturation ponds:** Shallow (1–1.2 m) with a large surface area to enable light penetration. They receive treated effluent from the facultative pond and provide tertiary treatment to remove turbidity, pathogens, and nutrients.

Where are they applicable?

- Waste stabilization ponds are appropriate for medium- to low-density settlements with sufficient free space, but should not be located very close to houses due to possible odor.
- They offer a robust treatment process that can deal with a wide variety of wastewaters of varying types and concentrations.
- Ponds are particularly appropriate where pathogen removal is an important objective of treatment.
- Waste stabilization ponds may be combined with aquaculture systems (duckweed, water hyacinth or fish production).

Mode of operation

- Treatment efficiency of high-loaded ponds with long retention times ranges from 70–95 percent BOD removal (COD removal: 65 percent to 90 percent) depending on biodegradability of the wastewater.
- Treatment efficiency increases with retention time but the number of ponds is not of major significance (splitting one pond into two ponds may increase performance by approximately 10 percent).
- Pond systems continue to operate well when overloaded beyond their theoretical design loads, but they will invariably fail if they are not maintained.
- Treatment in anaerobic and facultative ponds is based on microbial activity and settlement of suspended solids and sludge, while in maturation ponds it is achieved by solar radiation, predation by zooplankton, and the acidity created by photosynthesis.

Operation and maintenance requirements

- The commissioning of facultative ponds involves the development of algal culture and a heavily loaded anaerobic pond may release a bad odor until a layer of scum seals the surface.
- Routine operation and maintenance is easy but arrangements must be made for sludge removal. This is often done by emptying ponds and manually digging out the sludge. Alternatively, sludge can be removed under hydrostatic pressure using pumps mounted on rafts.
- Spraying to prevent fly breeding may be required at various times of the year.

Additional treatment requirements

- The three-stage process is a complete treatment system. The only additional requirement is for sludge treatment after its removal from ponds.

Limitations and risks

- Ponds require a lot of land, at least 5 m² per person.
- Underdesign, hydraulic short-circuiting, and poor operation and maintenance can all reduce performance.
- Possible problems related to odor and insects if the ponds are not managed properly, or are overloaded.

Management arrangements

- Performance and operation and maintenance practices need supervision and monitoring.

How much do they cost?

- *Capital costs:* Rs 1.5 million/MLD capacity (US\$36,500/MLD).

Sources of further information

- Mara, D. D. 1997. *Design Manual for Waste Stabilization Ponds in India*. Lagoon Technology International, Leeds, United Kingdom (www.leeds.ac.uk/civil/ceri/water/tphe/publicat/pdm/india.html).
- Arthur, J. P. 1983. 'Notes on the Design and Operation of Waste Stabilization Ponds in Warm Climates of Developing Countries'. Technical Paper, n. 7, Washington, D. C.
- Pescod, M. B. 1992. *Wastewater Treatment and Use in Agriculture*. Food and Agriculture Organization (FAO) Irrigation and Drainage Paper 47. United Nations (www.fao.org/docrep/T0551E/t0551e05.htm).
- www.irc.nl/page/14622 IRC. 2004. 'Waste Stabilization Ponds'.

Wastewater and Fecal Sludge Treatment: Activated Sludge Process

What is it?

- This process involves rapid mixing and aeration of the wastewater, either by mechanical surface aerators or a submerged compressed air system, to create optimal conditions for treatment.
- The aeration basin is followed by a secondary clarifier (settling tank) designed to remove suspended micro-organisms (flocs) prior to discharge. Active biomass is returned to the aeration tank.

Where is it applicable?

- Widely used for the treatment of municipal wastewater from medium to large towns where land is scarce and power is reliable.

Mode of operation

- Vigorous aeration elevates dissolved oxygen to create optimum conditions for aerobic bacterial growth. The bacterial population is maintained in suspension and grows rapidly, consuming large quantities of organic matter.
- A fraction of the settled microbial sludge is pumped back from the secondary clarifier to maintain an active population of micro-organisms and an adequate supply of biological solids for the adsorption of organic material.
- Provided the reactor is well operated, a very good removal of BOD and suspended solids can be achieved, though pathogen removal is low.
- Performance is critically dependent on the performance of secondary clarifier and the sludge settling characteristics.
- Sludge production depends on the sludge retention time in the reactor (an extended aeration process can reduce the quantity of sludge produced). Excess sludge is removed from the secondary clarifier and pumped to a separate sludge-handling process.

Operation and maintenance requirements

- A continuous supply of oxygen and sludge is essential; hence maintenance of the aeration equipment and sludge pump is important.
- Careful monitoring and control of concentrations of suspended sludge solids and dissolved oxygen levels in the aeration tank is required.

Additional treatment requirements

- *Pretreatment:* There is usually a need for primary sedimentation, but in many cases it is omitted, with only preliminary screening provided.

- *Posttreatment*: The treated effluent from the secondary clarifier may require additional treatment depending on the discharge requirements.
- *Sludge production and treatment*: Provision must be made to digest, dewater, and dispose of excess sludge.

Limitations and risks

- High energy consumption results in high recurring costs.
- Performance is adversely affected due to interruptions in power supply, even for short periods of time, due to impacts on aeration process and sludge recirculation.
- Foaming, particularly in the winter, may adversely affect the oxygen transfer, and hence performance.
- Mixing of industrial effluent with domestic wastewater can lead to toxicity and major malfunctioning.

Management arrangements

- The activated sludge process is technically complex and requires a highly competent and trained supervisor and workforce to be able to operate the system effectively.

How much does it cost?

- Smaller capacity plants tend to incur relatively high costs per volume of treated wastewater.
- *Capital costs*: In the range of Rs 4.2–4.8 million/MLD (US\$0.10–0.12 million/MLD). Approximately 55 percent cost is for civil works and remaining 45 percent is for electrical and mechanical works.
- *Operating costs*: In the range of Rs 0.43–0.52 million/year/MLD (US\$10,500–12,600/year/MLD).

Figure 17: Activated Sludge Process

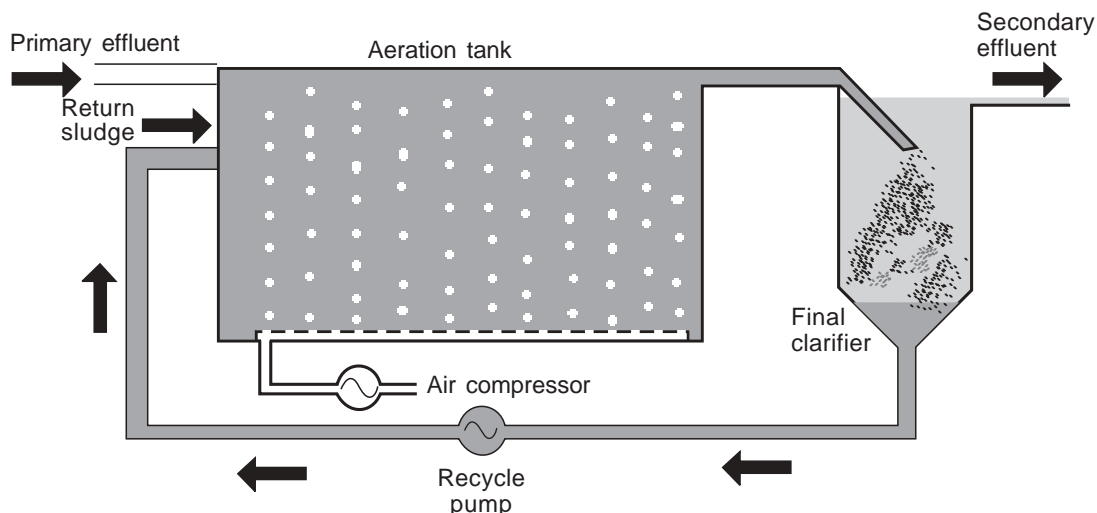

Wastewater Treatment: Biological Trickling Filter

What is it?

- An 'attached-growth' system comprising a circular tank filled with a bed of crushed aggregate, cylindrical plastic or foam blocks. Wastewater trickles vertically through the filter and the biomass growing on the media removes organic matter under aerobic conditions.

Where is it applicable?

- Can be used as a standalone treatment or a preliminary treatment for high strength wastewater in combination with activated sludge process or as a posttreatment operation for UASB effluent.
- Land requirement: Between 0.28 to 0.65 hectare/MLD.

Mode of operation

- A rotating arm distributes wastewater across the surface of the filter bed. Effluent is drained at the bottom.
- Micro-organisms growing on the media break down organic material to produce a consistent effluent quality and sludge with good settling characteristics.
- Bacteria use oxygen to convert ammonia in the effluent to nitrate and the BOD is reduced by 65–85 percent, nitrogen by 10–20 percent, and coliform bacteria by 60–90 percent.
- Recirculation of effluent may be required to avoid low flow conditions and reduce odor and flies.

Operation and maintenance requirements

- Relatively straightforward though hydraulic loading needs to be controlled to prevent the loss of biofilm. Clogging of screens must also be controlled.
- Maintenance of the turntable is required, as well as cleaning of stone filter media once in five or seven years or more.

Additional treatment requirements

- *Pretreatment:* Primary sedimentation is compulsory to avoid clogging of filter bed.
- *Posttreatment:* Effluent requires secondary clarification.
- *Sludge treatment:* Excess sludge production = 0.8 kg/kg of BOD removed. Thickening, digestion, and drying are required.

Limitations and risks

- Mechanical breakdown of the distribution arm is common; ponding resulting from blockages due to excess biofilm growth can also be a problem.
- High organic loadings can create anaerobic conditions on the filter, causing an odor problem.
- Filter flies (*Psychoda*) may proliferate due to inadequate filter media moisture.

Management arrangements

- Low-skilled manpower requirements under technical supervision.

How much does it cost?

- *Capital costs:* Rs 13.2 million (US\$0.32 million) per MLD capacity

Sources of further information

- Arceivala, Soli J. 1998. *Wastewater Treatment for Pollution Control, 2nd ed.* Tata McGraw-Hill Publishing Company Ltd.

Figure 18: Biological Trickling Filter

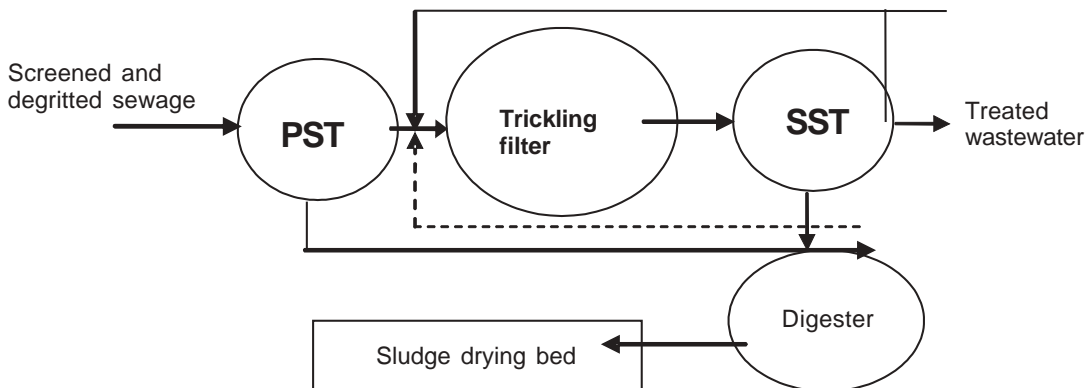

Wastewater Treatment: Fluidized Aerated Bed (FAB) Reactor

What is it?

- An aerobic process in which wastewater flows vertically upwards through a filter bed of lightweight inert media at a sufficient velocity to 'fluidize' the bed. A bacterial biofilm develops on the media particles and treats the wastewater as it passes through.

Where is it applicable?

- Good for treatment of small to medium flows in congested locations. Being a closed reactor, it is suitable for sensitive locations.

Mode of operation

- High BOD removal with effluent concentration under 10 mg/l and high suspended solids removal with effluent concentration under 20 mg/l.
- Fecal coliforms removal for a two-stage FAB.
- Electrical energy requirement rather low (between 99 to 170 kWh/MLD).

Additional treatment requirements

- Secondary settling, sludge removal, thickening, and drying. Digestion is not required as the sludge is stabilized.

Management arrangements

- Straightforward operation but requires a skilled workforce.

Limitations and risks

- Reliance on patented filter media.
- Choking of reactor by floating plastic matter and of outlet by fluidized media. Excess biomass growth or low hydraulic loads can result in blockages.
- Long shutdowns may lead to septic conditions, and restart may involve a long stabilization period.
- Uncertain durability of media under varying climatic conditions.

How much does it cost?

- *Capital costs:* Rs 5–200 million/MLD (US\$0.12–4 million/MLD) for plants of 0.5–40 MLD capacity. Filter media accounts for roughly one-third of the cost.
- *Operating costs:* Rs 0.6–0.75 million/MLD/annum (US\$14,000–18,000/MLD/annum).

Figure 19: Fluidized Aerated Bed (FAB) Reactor

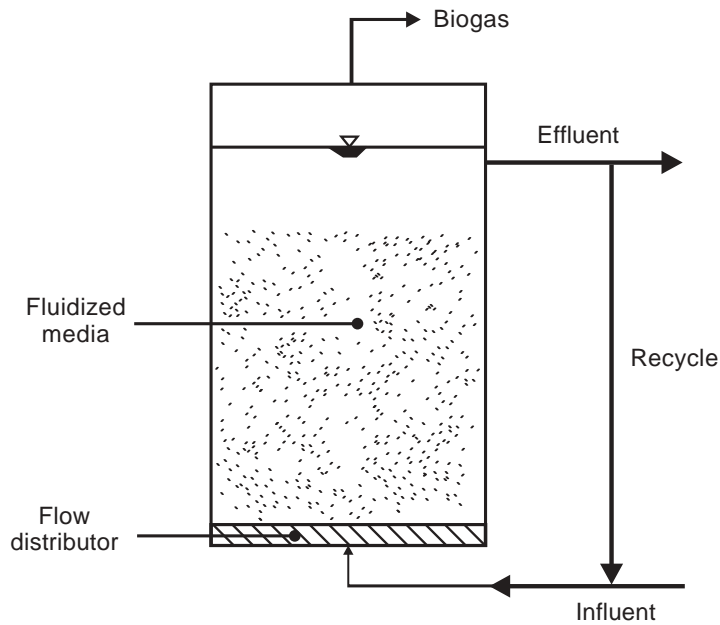

Wastewater Treatment: Upflow Anaerobic Sludge Blanket (UASB)

What is it?

- Wastewater flows upwards through a blanket of flocculated biomass in a vertical reactor containing anaerobic bacteria which break down carbonaceous organic matter.

Where is it applicable?

- Best suited to higher strength wastewaters: blackwater and industrial wastewater, but can also treat lower strength domestic wastewater.
- Appropriate for medium-size wastewater treatment plants.
- UASBs need less land than aerobic systems but require follow-up treatment to achieve comparable performance in terms of COD/BOD removal.

Mode of operation

- The upward motion of gas bubbles produced during anaerobic digestion causes turbulence that enables mixing without mechanical assistance. Baffles at the top of the reactor allow gases to escape but prevent outflow of the sludge blanket.
- No external energy requirements in the reactor, thereby the process is not vulnerable to power cuts.
- Can bring down BOD of domestic wastewater to 70–100 mg/l and suspended solids as low as 50–100 mg/l, but removal of nitrogen and bacteria is poor.

Additional treatment requirements

- *Pretreatment:* Screening and degritting but no other form of primary treatment is required.
- *Posttreatment:* Like other anaerobic treatment technologies, UASBs only provide partial treatment and rarely meet discharge standards unless appropriate post-treatment is provided. As yet, only a waste stabilization pond system has been found to be an appropriate post treatment option.
- *Sludge production and treatment:* Relatively low sludge production with good dewatering characteristics. Requires thickening, drying, and safe disposal.

Operation and maintenance requirements

- Careful monitoring and control of the reactor sludge levels and sludge withdrawal.
- Frequent cleaning or desludging of distribution or division boxes and influent pipes.
- Removal of scum and floating material from the settling zone.
- Control of the flow rate is difficult for small units.
- Prevent mixing of industrial effluents with toxic elements and sulfates or sulfides.

Management arrangements

- Skilled supervision during start-up and for control of biomass levels in the reactor.

Limitations and risks

- Long start-up and high initial oxygen demand of effluent during this period may cause oxygen depletion in receiving water bodies.
- Sensitive to seasonal temperature variations and low removal efficiency in winter.
- Release of corrosive and odorous hydrogen sulfide and ammonia in the air.
- Sludge washout from the reactor can result in instability leading to deteriorations in treatment performance and very high BOD and total suspended solids in the effluent.

How much does it cost?

- *Capital costs:* Rs 2.4–3.5 million/MLD (US\$58,500–85,000/MLD) depending on the capacity of the plant. Approximately 65 percent cost is of civil works and remaining 35 percent is for electrical and mechanical works.
- *Operating costs:* Rs 0.07–0.15 million/MLD/annum (US\$1,700–3,600/MLD/annum) depending on plant capacity.

Practical experiences

- 14 MLD domestic wastewater treatment plant in Mirzapur.
- 36 MLD tannery wastewater treatment plant in Kanpur.
- In India, see: Tare, Vinod, and Asit Nema. April 2006. *Sewage Treatment through UASB Technology—Expectations and Reality*. 22nd National Convention on Environmental Engineering, Institution of Public Health Engineering and IT-BHU, Varanasi, India.
- Elsewhere: There has been considerable interest in the UASB as an appropriate form of wastewater treatment in other developing countries, notably Brazil.

References and sources of further information

- Bal, A. S., and N. N. Dhagat. April 2001. 'Upflow Anaerobic Sludge Blanket Reactor: A Review'. *Indian J Environ Health*,. 43(2):1–82. National Environment Engineering Research Institute (NEERI).

Figure 20: Upflow Anaerobic Sludge Blanket (UASB)

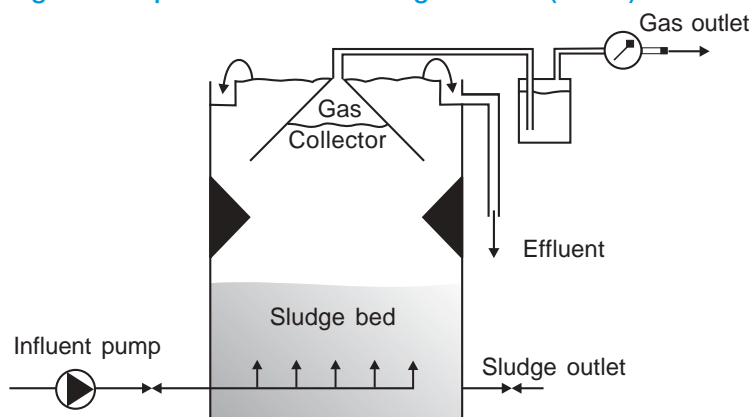

Source: Integrated Approach and Replicability. March 1994. Indo-Dutch Environmental and Sanitary Engineering Project, Kanpur-Mirzapur.

Wastewater Treatment: Upflow Anaerobic Filter

Also known as fixed bed or fixed film reactor.

What is it?

- Anaerobic filters provide additional treatment by bringing wastewater into contact with active bacteria attached to media as the wastewater flows upwards through the filter. Filter material, such as gravel, rocks, cinder or specially formed plastic pieces provide additional surface area for bacteria to form a slime.

Where is it applicable?

- Appropriate for treating effluent from septic tanks (individual or shared/communal) in areas where infiltration is not possible due to low soil permeability, high water table and/or lack of space.

Mode of operation

- There is no physical straining of particulates; nonsettleable and dissolved solids are removed through close contact with a surplus of active bacterial mass.
- May be operated as downflow or upflow systems. Upflow is generally preferred as there is less risk of washing out active bacteria, but cleaning of the filter is easier with the downflow system.
- Treatment quality (when combined with pretreatment) can be as high as 80 percent BOD removal.

Operation and maintenance

- Active sludge (for example, from septic tanks) should be added to the filter before starting continuous operation.
- The bacterial film gradually thickens and must eventually be removed. This is usually done by back-washing with wastewater.

Additional treatment requirements

- The filter should be preceded by a septic tank.

Limitations and risks

- Lack of attention to maintenance results in blockage of the filter. In addition, the perforations of the distribution pipe at the bottom of the filter get clogged easily.
- On average, 25–30 percent of the total filter mass may be inactive due to clogging. While a cinder or rock filter may not block completely, reduced treatment efficiency is indicative of clogging in some parts.

- A sand or gravel filter may block completely due to smaller pore size resulting in backup of wastewater into the septic tank.

Management arrangements

- Responsibility will normally lie with the manager of the property served.

How much does it cost?

- No data available.

Practical experience

- Research in Thailand found that operational problems with household septic tanks and upflow anaerobic filters resulted from the perforations in the distribution pipe clogging easily.

References and sources of further information

- IRC. 1997. *Operational and Maintenance Problems of Septic Tank with Anaerobic Upflow Filter*. Chiang Mai, Thailand.
- Sagar, G. 1983. 'A Dwarf Septic Tank Developed in India'. *Waterlines*, Vol 2 (1). July 1983.

Figure 21: Upflow Anaerobic Filter

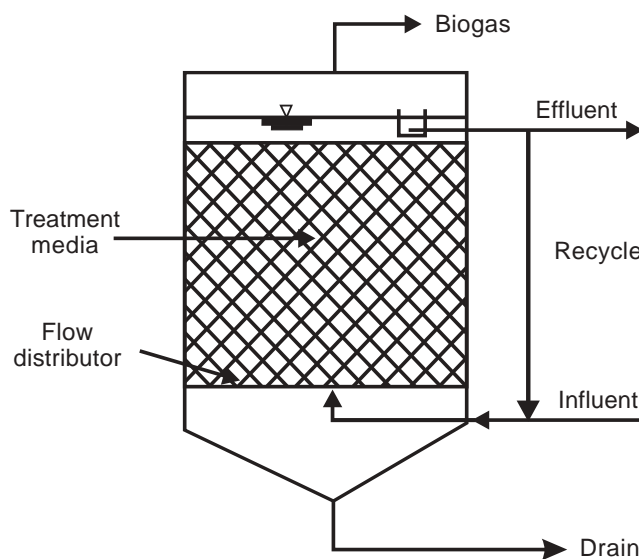

Wastewater Treatment: Duckweed Ponds

What is it?

- Duckweed (*Lemnaceae*) is a small, floating, and fast growing aquatic plant that grows vigorously in pretreated wastewater to produce a protein-rich biomass.
- Duckweed-based pond systems take nutrients from wastewater and produce a highly nutritious feed for fish, poultry or livestock. Fish yields may be two to three times higher than in conventional ponds.

Where is it applicable?

- Appropriate for treating low strength domestic wastewater or as a polishing treatment after primary sedimentation.
- Requires a considerable amount of land (5–10 m² per person for 7- or 20-day retention period).
- Best suited for rural and semiurban settlements.

Mode of operation

- Duckweed-based systems are a modification of conventional lagoon technology with the pond functioning as a facultative lagoon. Deeper layers are anaerobic.
- Duckweed grows rapidly and is harvested for use as a mulch or natural soil enricher. Harvesting promotes growth and removal of nutrients and dissolved carbon from the wastewater.
- Algal growth is suppressed by duckweed due to competition for sunlight and nutrients and possibly secretion of organic substances.
- Duckweed suppresses mosquito breeding by forming a mat over the water surface.

Operation and maintenance requirements

- Relatively simple maintenance: Frequent duckweed harvesting from the surface to ensure productivity, prevention of other vegetative growth, and control of wave action using bamboo or similar vegetation.
- The pond needs desludging every two or three years.

Additional infrastructure or treatment requirements

- Pretreatment required if used as part of a wastewater treatment process. This often takes the form of a waste stabilization pond but other forms of treatment can be used.

Limitations and risks

- Low pathogen removal due to reduced light penetration.
- Duckweed dies in cold weather.

- If flows are not adequately controlled, duckweed can flow out with the effluent. Treatment capacity may be lost during floods.

Management arrangements

- Technical and commercial skills are needed for the production, marketing, and sale of dried duckweed for animal or fish feed if this is to succeed as a microenterprise.

How much does it cost?

- *Capital costs:* Of the same order as waste stabilization ponds with the additional cost of floating cell material (to control flows). Estimated at Rs 1.9 million/MLD (US\$46,000/MLD) capacity.
- *Operating costs:* Rs 0.18 million/MLD/year (US\$4,000/MLD/year).

Links to other technologies

- Waste stabilization ponds.

Examples of application

- Duckweed ponds have been piloted on a limited scale in Delhi, Haryana, West Bengal, and Orissa in both rural and urban locations. They have also been used in Bangladesh.

References and sources of further information

- Gijzen, H. J., and M. Ikramullah. 1999. *Pre-Feasibility Study of Duckweed-Based Wastewater Treatment and Resource Recovery in Bangladesh*. World Bank.
- Iqbal, S. 1999. *Duckweed Aquaculture Potentials, Possibilities and Limitations for Combined Wastewater Treatment and Animal Feed Production in Developing Countries*. SANDEC Report No. 6/99. EAWAG, Switzerland.

Glossary

Activated sludge: An aerobic treatment process in which oxygen and micro-organism concentrations in wastewater are artificially elevated to facilitate rapid digestion of biodegradable organic matter.

Aerated pond or lagoon: A natural or artificial wastewater treatment pond in which mechanical or diffused air aeration is used to supplement the natural reoxygenation processes.

Aerobic treatment: Treatment of wastewater with the help of micro-organisms that rely on oxygen.

Anaerobic digestion: Decomposition of organic material by anaerobic bacteria in the absence of air.

Anaerobic lagoon: A system for treatment of high-strength wastewater and sludge that involves retention under anaerobic conditions.

Biochemical oxygen demand: A measure of the organic pollutant strength of wastewater.

Biosolids: See **Sewage sludge**.

Blackwater: Wastewater discharge from toilets.

Bucket latrine: A traditional but unhygienic form of sanitation in which feces is deposited into a bucket which is collected regularly (usually at night) and taken away (usually by 'sweepers').

Composting latrine: A latrine designed to receive both feces and waste vegetable matter with the aim of reducing moisture content and achieving a carbon-to-nitrogen ratio that promotes rapid decomposition.

Dry latrines: All forms of latrines that do not require water for flushing.

Desludging: Removal of sludge or settled solid matter from treatment tanks such as septic/Imhoff tank, interceptor tank or sedimentation tanks.

Disposal: Discharge, deposition or dumping of any liquid or solid waste onto land or water so that it may enter the environment.

Domestic sewage: All forms of wastewater derived from residential properties, as well as blackwater and greywater from commercial and institutions buildings.

Dry sanitation: Disposal of human excreta without the use of water for flushing or anal cleansing.

Ecological sanitation (ecosan): A form of dry sanitation that involves separation of feces and urine in order to facilitate recycling of nutrients in local agricultural systems.

Effluent: Any form of wastewater or liquid waste that flows from an operation or activity.

Excreta: Feces and urine.

Fecal sludge: The undigested sludge that is collected from pit latrines and leach pits.

Greywater (also known as sullage): Wastewater produced by washing and bathing activities.

Lagoon: See technology data sheet on 'Wastewater and Fecal Sludge Treatment: Waste Stabilization Ponds' (page 104).

Leachfield: A trench filled with sand, soil, gravel and brickbats for disposal of septic tank overflow into the surrounding soil.

Leach pit (sometimes known as a cesspit): An underground tank that is used where there is no sewer and household wastewaters are drained into them to permit leaching of the liquid into the surrounding soil.

Night soil: Human excreta, with or without anal cleansing material, which are deposited into a bucket or other receptacle for manual removal.

On-plot sanitation: A sanitation system that is wholly contained within the plot occupied by a private dwelling and its immediate surroundings. Commonly, on-plot sanitation is equivalent to 'household latrine', but may also include facilities shared by several households living together on the same plot.

On-plot facilities: The components of a sanitation system located within a householder's plot.

Off-site sanitation: A system of sanitation that involves collection and transportation of waste (wastewater either by sewerage or septage/fecal sludge by vacuum truck) to a location away from the immediate locality.

Pathogens: Micro-organisms such as bacteria, viruses and protozoa that cause disease.

Percolation rate: The rate at which liquids move through soil.

Pit latrine: A form of on-plot sanitation with a pit for accumulation and decomposition of excreta from which liquid infiltrates into the surrounding soil.

Pour flush toilet: A type of latrine where a water seal trap is used to prevent smells and to reduce insects.

Sanitation: Interventions (usually construction of facilities such as latrines) that improve the management of excreta and promote sanitary (healthy) conditions.

Septage: Mixture of wastewater and sludge removed from a septic tank during cleaning operations.

Septic tank: A form of on-plot sanitation for the anaerobic treatment of sewage/blackwater.

Sewage: A mixture of wastewater from all urban activities from residential, commercial properties. It may also contain a component of industrial wastewater.

Sewer: A conduit, usually a pipe, which is used to collect and convey wastewater away from its point of production to its point of disposal.

Sewage sludge (sometimes referred to as biosolids): A semisolid residue generated during the treatment of domestic sewage including both solids removed by sedimentation and biological sludge produced by biological treatment.

Sewerage: A network of interconnected sewers in an area, district or town.

Soak pit/Soakaway: A pit, typically after a septic tank from where wastewater slowly seeps into the ground through perforated sides and bottom.

Sullage (also known as greywater): Wastewater from bathing, laundry, preparation of food, cooking, and other personal and domestic activities.

Superstructure: Screen or building enclosing a latrine to provide privacy and protection for users.

Suction truck: A vehicle used for mechanized sludge removal from septic tanks and lined latrine pits.

Ventilated improved pit latrine (VIP): A dry latrine system, with a dark interior and a screened vent pipe to reduce odor and fly problems.

Vent pipe: A pipe that facilitates the escape of gases and odors from a latrine or septic tank.

Wastewater: Liquid wastes from households or commercial or industrial operations, along with any surface water/storm water.

Wastewater treatment: A combination of physical, chemical, and biological processes to remove suspended solids, dissolved pollutants, and pathogens and render the water harmless to the environment.

Water closet: A pan, incorporating a water seal, in which excreta are deposited before being flushed away using water.

Water seal: Water held in a U-shaped pipe or hemispherical bowl connecting a pan to a pipe, channel or pit to prevent the escape of gases and insects from the sewer or pit.

References and Sources of Additional Information

- ADB (Asian Development Bank). 2006. *Model Terms of Reference: Planning Urban Sanitation and Wastewater Management Improvements*. www.adb.org/Water/tools/pdf/Planning-Urban-Sanitation-TOR.pdf
- Alaerts, G. J., S. Veenstra, M. Bentvelsen, L. A. van Duijl, *et al.* 1991. 'Feasibility of Anaerobic Sewage Treatment in Sanitation Strategies in Developing Countries'. *IHE Report Series 20*, International Institute for Hydraulic and Environmental Engineering, Delft.
- Cotton, A. P., and D. L. Saywell. 1998. *On-Plot Sanitation in Low-Income Urban Communities: Guidelines for Selection*. WEDC. Loughborough University, Loughborough.
- Department for International Development. 1999. *DfID Guidance Manual on Water Supply and Sanitation Programmes*. WELL Resource Centre, Loughborough University, UK.
- Feachem, R. G., J. B. David, G. Hemda, and D. D. Mara. 1983. *Sanitation and Disease: Health Aspects of Excreta and Wastewater Management*. World Bank, Washington, D. C.
- Franceys, R. 1997. 'Private Sector Participation in the Water and Sanitation Sector'. *Water Resources Occasional Papers No 3*. DfID WELL Task paper. WEDC, Loughborough University and IHE, Delft.
- Franceys, R., J. Pickford, and R. Reed. 1992. *Guide to the Development of On-Site Sanitation*. World Health Organization.
- Heinss, U., S. A. Larmie, and M. Strauss. 1997. *Solids Separation and Pond Systems for the Treatment of Faecal Sludges in the Tropics*. SANDEC Report No. 5/97. Dübendorf, Switzerland.
- IETC (International Environmental Technology Centre). 2002. *International Source Book on Environmentally Sound Technologies for Wastewater and Stormwater Management*.
- Iqbal, S. 1999. *Duckweed Aquaculture Potentials, Possibilities and Limitations for Combined Wastewater Treatment and Animal Feed Production in Developing Countries*. SANDEC Report No. 6/99. EAWAG, Switzerland.

- IRC. 1997. *Operation and Maintenance of Sanitation Systems in Urban Low-Income Areas in India and Thailand*. Report on a joint research programme, 1989-1993. Project and Programme Papers 6-E, International Research Centre (IRC), Netherlands.
- Khouri, N., J. M. Kalbermatten, and C. Bartone. 1994. *The Reuse of Wastewater in Agriculture: A Guide for Planners*. UNDP–World Bank Water and Sanitation Program. World Bank, Washington, D. C.
- Ludwig, H. F., H. Fennerty, K. L. Sow, and K. Mohit. 2005. *Textbook of Appropriate Sewerage Technology for Developing Countries*. New Delhi: South Asian Publishers Pvt Ltd.
- Mara, D., and S. Cairncross. 1989. *Guidelines for the Safe Use of Wastewater and Excreta in Agriculture and Aquaculture*. Geneva: United Nations Environmental Programme/World Health Organization.
- Mara, D. D. 1985. *The Design of Pour-Flush Latrines*. TAG Technical Note No. 15. Washington, D. C.: World Bank.
- Mara, D. D. 1996. *Low-Cost Urban Sanitation*. England, Chichester: John Wiley and Sons.
- Mara, D. D. 1997. *Design Manual for Waste Stabilization Ponds in India*. National River Conservation Directorate, Ministry of Environment and Forest, Government of India, and Department for International Development, UK.
- Mara, D. D. 1998. *Low-Cost Sewerage*. England, Chichester: John Wiley and Sons.
- Mara, D. D., A. Sleight, and K. Tayler. 2000. *PC-Based Simplified Sewer Design*. Leeds: University of Leeds (School of Civil Engineering).
- Ministry of Urban Development. 1995. *Manual on Sewerage and Sewage Treatment, 2nd edition*. New Delhi: Government of India Press.
http://urbanindia.nic.in/moud/publicinfo/manual_sewage.htm
- Morel, A., and S. Diener. 2006. *Greywater Management in Low and Middle-Income Countries—A Review of Different Treatment Systems for Households or Neighbourhoods*. SANDEC, Switzerland.
- Otis, R.J., and D. D. Mara. (1985). *The Design of Small Bore Sewer Systems*. TAG Technical Note No. 14. Washington, D. C.: World Bank.

- Roy, A. K., et al. 1984. *Manual on the Design, Construction and Maintenance of Low-Cost Pour-Flush Waterseal Latrines in India*. TAG Technical Note No. 10. Washington, D. C.: World Bank.
- Sansom, K., R. Franceys, Cyrus Njiru, and J. Morales-Reyes. 2003. *Contracting out Water and Sanitation Services: Volume 1. Guidance Notes for Service and Management Contracts in Developing Countries*. WEDC, Loughborough University, UK.
- Sasse, L. 1998. *DEWATS Decentralised Wastewater Treatment in Developing Countries*. BORDA (Bremen Overseas Research and Development Association), Bremen.
- Sinnatamby, G. S. 1986. *The Design of Shallow Sewer Systems*. Nairobi: United Nations Centre for Human Settlements.
- Taylor, K., J. Parkinson, and J. Colin. 2003. *Urban Sanitation: A Guide to Strategic Planning*. UK: Practical Action Publications.
- UNEP (United Nations Environment Programme). 2004. *Guidelines on Municipal Wastewater Management*. Version 3. UNEP; WHO; UN-HABITAT and WSSCC (2004). The Hague, The Netherlands, UNEP GPA.
- US-EPA (United States–Environmental Protection Agency). 2002. *Onsite Wastewater Treatment Systems Manual*. EPA/625/R-00/008 February 2002. www.epa.gov/nrmrl/pubs/625r00008/html/625R00008.htm

ACKNOWLEDGMENTS

The Guidance Note has been peer reviewed by Dr. R. Sethuraman (CPHEEO), Eduardo A. Perez, Kevin Tayler, Pravin More, Martin Gauss

AUTHORS

Jonathan Parkinson, Kevin Tayler, Jeremy Colin, and Asit Nema

TASK MANAGER

Soma Ghosh Moulik

TEAM MEMBERS

Sara Almqvist and Vivek Raman

Edited by: Anjali Sen Gupta

Pictures by: Sajid Darokhan, C. Ajith Kumar, WSP-SA/Guy Stubbs

Designed and Printed by: Roots Advertising Services Pvt Ltd



Water and Sanitation Program-South Asia

The World Bank
55 Lodi Estate, New Delhi 110 003
India

Phone: (91-11) 24690488, 24690489

Fax: (91-11) 24628250

E-mail: wsp@worldbank.org

Web site: www.wsp.org



सत्यमेव जयते
Government of India

Ministry of Urban Development

Nirman Bhawan
New Delhi 110 011
India

Phone: (91-11) 23022199

Fax: (91-11) 23062477

E-mail: secyurban@nic.in