

Low Cost Systems for the Management of Sludge from Toilets and Shower Units

Current Techniques and Improved Options in Ambositra and Mahanoro (Madagascar)



The WASHplus project supports healthy households and communities by creating and delivering interventions that lead to improvements in water supply, sanitation, and hygiene (WASH) and indoor air quality (IAQ). This five-year project (2010-1015) funded through USAID's Bureau for Global Health (AID-OAA-A-10-00040), uses at-scale programming approaches to reduce diarrheal diseases and acute respiratory infections, the two top killers of children under five years of age globally. WASHplus can integrate WASH and IAQ activities into existing education, HIV/AIDS, maternal and child health, nutrition programs and education programs build strong in-country partnerships to increase impact. In addition, WASHplus is charged with promoting innovation in the WASH and IAQ sectors.

May 2011

Contact Information:

WASHplus Project
1825 Connecticut Avenue, NW
Washington, DC 20009-5721
www.washplus.org

Submitted to:

Merri Weinger
Office of Health, Infectious Diseases and Nutrition
Bureau for Global Health
U.S. Agency for International Development
Washington, DC 20523



Table of Contents

1. Introduction	1
2. Management of Toilet and Shower Units in Ambositra and Mahanoro	2
2.1. Toilet and Shower Units by C-Change/HIP	2
2.1.1 The Case of Ambositra	2
2.1.2 The Case of Mahanoro	3
2.2. Maintenance of the Pits	4
2.2.1 General Considerations	4
2.2.2 The Case of Ambositra	6
2.2.3 The Case of Mahanoro	6
3. Management of Fecal Sludge in Ambositra and Mahanoro	7
3.1 Existing Services in Ambositra	7
3.2 Services Existing in Mahanoro	8
3.3 Local Techniques for Emptying Pits	8
4. Appropriate Systems Proposed for Managing Sludge from Public Toilets	12
4.1 Alternative Technologies	12
4.2 Technical Options Proposed	14
4.2.1 Basis for the Design	14
4.2.2 Removal of Sludge	14
4.2.3 Transportation of Sludge	16
4.2.4 Disposal/Treatment Sites	18
4.2.5 Disposal/Treatment Techniques	19
4.2.6 Technical Process Proposed	22
4.2.7 Financial Aspects	23
4.3. Structure of a Sludge Management Service	24
4.4. Sludge Management Service for Private Latrines	27
Annex 1	29
Annex 2	31
Annex 3	32
Annex 4	37
Annex 5	38

1. Introduction

In countries in the southern hemisphere, sanitation coverage is ensured at 70 percent through individual facilities, which are the most accessible technical option in both rural areas and urban settings (Department of Water and Sanitation in Developing Countries, at the Swiss Federal Institute of Aquatic Research and Technology).

Under this sanitation system, excreta are stored in pits where fecal matter undergoes partial decomposition and forms sludge that must be regularly emptied out.

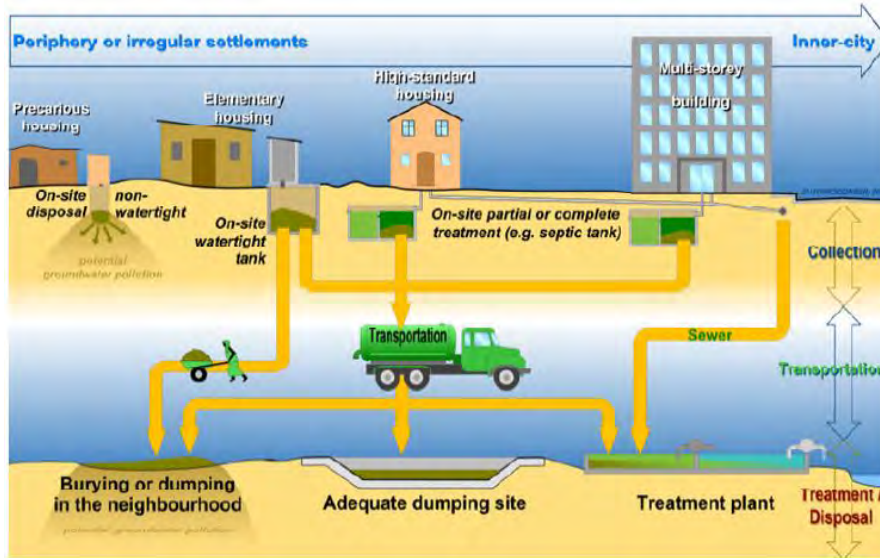

Overview of sanitation in developing countries (source: Hydroconseil)

As illustrated in the graph above, pits can be emptied two ways: through the use of cesspit emptiers (conventional method) and manual emptying, which is done informally in many cases and is unhealthy in general. In addition, dedicated areas rarely exist for discharging sludge, let alone sludge treatment plants. This is the case in Madagascar where all the emptied sludge is discharged in human settlement areas and rivers.

In the context where proper excreta disposal is not available, efforts to build and use latrines only delay the impact of open defecation instead of eliminating it. This applies to public toilet and shower units found in neighborhoods where households cannot build their own facilities or to congested areas such as marketplaces and bus stations. These facilities generate significant amounts of sludge, which presents a very complex management issue.

At the behest of the U.S. Agency for International Development (USAID) funded WASHplus project, PRACTICA assessed the current situation and suggested appropriate options for the management of sludge from three toilet and shower units. These units were rehabilitated in July 2010 by the USAID Hygiene Improvement Project (HIP) in two regional sites, Ambositra and Mahanoro.

Management of Toilet and Shower Units in Ambositra and Mahanoro

2.1. Toilet and Shower Units by C-Change/HIP

2.1.1 The Case of Ambositra

Ambositra is an urban commune with more than 32,800 inhabitants and is located in the region of Amoron'i Mania in the central highlands of Madagascar.

The commune is connected to the network of the national water company JIRAMA and the water is extracted from Lake Tsiandrazandoha, nine kilometers from the town, in Anasana in the rural commune of Ankazoambo. In regard to sanitation, the latrine-use rate was estimated at 92 percent at the regional level in 2009 (Base de Données Eau et Assainissement – BDEA).

In July 2010 C-Change/HIP rehabilitated two toilet and shower units in the neighborhood of Alakamisy, near the bus station, and in the neighborhood of Sabotsy, near the marketplace. While the commune owns the facilities, the municipality contracted the management to private managers.



Toilet and shower unit in Alakamisy

C-Change/HIP's Management Contract

(Excerpt from the contract on the unit in Alakamisy)

Article 10-b: Maintenance and repairs: the Manager shall perform at its expense the running upkeep, maintenance, and repairs of the unit.

Article 10-c: Production of documents: the Manager (...) shall produce a technical activity report and a financial report to the Contracting Authority.

Article 13: Duties of the Contracting Authority: The Contracting Authority will be in charge of (...) d) (...) extension project, renewal, major maintenance (including refurbishing the septic tank) it may deem necessary... f) use the fees collected [from the manager] to invest in the construction of another toilet and shower unit or any other facility.

Article 17: The Manager shall pay a fixed fee of Malagasy Ariary (MGA) 200,000 (...) the payment will be done no later than one week after the elapsed month.

Management committees ultimately play the supervisory role, and C-Change/HIP monitors.

During field visits, only the manager in charge of the unit in Sabotsy could produce a streamlined loss/profit account:

Loss/Profit Account	Amount	Revenues in MGA	Expenses in MGA
Stand pipe		85,580	
Toilet users	2,787	278,700	
Urinal users	2,140	107,000	
Shower users	126	50,400	
Fees	1		120,000
Water consumption	79 m ³		40,146
Payroll	/month		70,000
Repairs	/month		10,000
Upkeep material	/month		5,000
Total		521,680	245,146
Profit		276,534	



Loss/profit account for the toilet and shower unit in Sabotsy (January 2011)

Inside the toilet and shower unit

With a monthly turnover of MGA (Malagasy Ariary) 520,000 and a monthly profit of MGA 280,000 (about US \$120), the operation of toilet and shower units in Sabotsy is a profitable activity.

2.1.2 The Case of Mahanoro

Mahanoro is a commune located on the eastern coast of Madagascar in the Atsinanana region with 39,879 inhabitants. It was recently upgraded to an urban commune.

Water in the town is provided by the national water company JIRAMA, which uses a borehole, but most of the population uses a “tany” pump to draw from the shallow groundwater. The sanitation access rate at the regional level was 65 percent in 2009 (BDEA). In addition, the population uses latrine buckets made from low-volume metal barrels that are emptied onsite.

The town has a toilet and shower unit next to the marketplace, and the facility is managed by a woman from Manakara. According to the mayor, no one in the village wanted to take the job for fear of damage to his/her social image. The toilet and shower unit is well kept and receives many users, as reflected in the following table.



Loss/Profit Account	Amount	Revenues in MGA	Expenses in MGA
Toilet users	3,600	360,000	
Urinal users	600	30,000	
Shower users	210	84,000	
Fees	1		200,000
Payroll	1		70,000
Repairs	/month		10,000
Upkeep material	/month		5,000
Total		474,000	245,146
Profit		189,000	

Loss/profit account for the toilet and shower unit in Mahanoro (January 2011)



The toilet and shower unit

The operation of the toilet and shower unit in Mahanoro also results in profits. As shown above:

- The monthly gross profit from the operation of the toilet and shower unit is about MGA 400,000 with a daily average of 160 to 200 users.
- The management delegation contract does not clearly specify whether the task of emptying the pits falls to the commune or the manager. However, the profits resulting from the unit's operation should cover the cost of this task.

2.2. Maintenance of the Pits

2.2.1 General Considerations

The three toilet and shower units use a septic system under which excreta are flushed then processed in a suite of chambers for anaerobic digestion, settlement, and filtration through a bacterial bed (pozzolana).

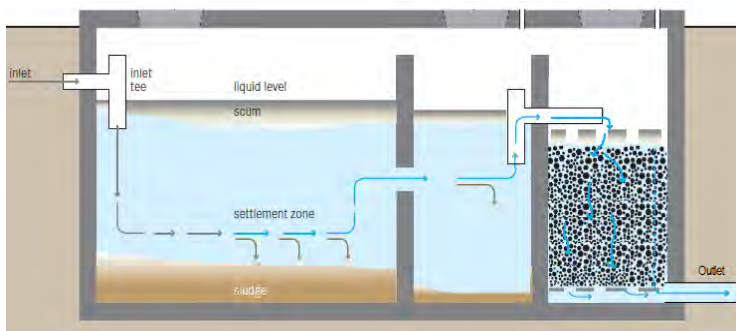

Model of a septic tank installed in the toilet and shower units



The pit must be checked every three months to ensure that the sludge does not obstruct the system. To this end, the slabs must be lifted and the sludge level measured with a pole. At the same time, the T-shaped pipe and the bacterial bed must be checked to ensure they are not obstructed.

Emptying the pits actually consists of removing the excess sludge and potential solid waste. It is not aimed at disinfecting the pit. If the pit operates well, it is possible to empty only the scum on top and the sludge at the bottom and leave the liquid. In addition, the pit must not be fully emptied, as a layer must be left to allow for the digestion process.

The frequency for emptying a pit is determined at the beginning stage of design. The following formula (*FRANCEYS*) incorporates the different parameters of a septic tank into the calculation of the frequency for emptying it:

$$F = \frac{V_f - V_e}{N \times F_e \times A}$$

Where:

F: number of years between two emptying operations

V_f: Total capacity of the pit (in liters)

V_e: Daily volume of water entering the pit (in liters)

N: Number of resident users

F_e: Environmental factor (1.5 in our case)

A: Average sludge accumulation rate (80l/user/year)

To keep the pit in good operating condition, it should be emptied on average every two to five years.

2.2.2 The Case of Ambositra

During an inspection conducted as part of PRACTICA's assessment, it was noted that the pits of the two toilet and shower units in Ambositra were in urgent need of being emptied. The sludge and scum started obstructing the pits' drains up to the level of the bacterial filters as seen in the pictures below.



Ambositra: Mobile manholes should be installed to make it easier to check the pits. The sludge has thickened and does not settle. The drains are obstructed. The pits lack maintenance.

Thus, eight months into service, the septic tanks of the toilet and shower units already had to be emptied. This seems to confirm the soundness of the formula above, whose application shows that the pits have to be emptied every seven months for Sabotsy and every nine months for Alakamisy due to their intensive use (see calculations in Annex 1).

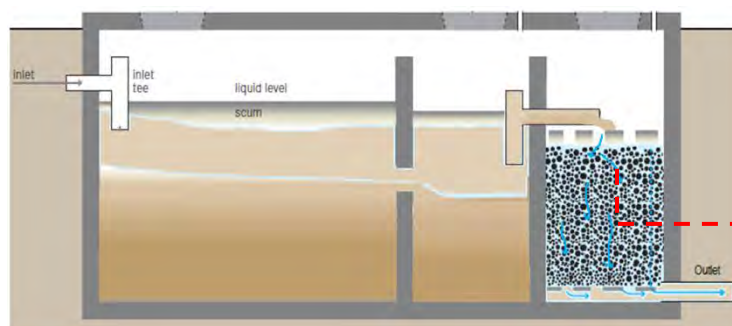

Ambositra: The pit should be urgently emptied to avoid obstruction.

2.2.3 The Case of Mahanoro

The toilet and shower unit in Mahanoro is fitted with a large pit (12.8 m³) with a design complicated by numerous repairs and rehabilitations.

A checkup did not find any major problem. The pit seems to operate normally but given the toilets' level of use, the pit should be emptied every year (see calculations in Annex 1).

In general, the pits have to be emptied quite frequently. With the current level of use, this should be done every eight months in Ambositra and every 15 months in Mahanoro. The managers should be able to control the pits and decide when it is necessary to empty them.

3. Management of Fecal Sludge in Ambositra and Mahanoro

Due to the predominance of standalone sanitation and the increasing density of urban settlements, ensuring sound management of fecal sludge is a growing need in Ambositra and Mahanoro.

3.1 Existing Services in Ambositra

While the town of Ambositra has a unit in charge of sanitation that organizes the collection of domestic waste, it has neither a formal service for emptying pits nor a cesspit emptier.

The assessment identified three informal pit emptying teams. One of them includes four municipal employees who in their regular jobs are in charge of maintenance and garbage collection. Occasionally, they offer their services, as private operators, to public institutions, offices, or private people. The two other teams are comprised of two and three members, respectively.

The informal teams do not keep record of their work. They indicated that the cost of emptying a pit ranges from MGA 20,000 (\$10) to MGA 120,000 (\$60) and that they empty from three to 24 pits per year. During the assessment, it was noted that the toilet and shower unit managers negotiated services with them for MGA 50,000 (\$25) and one bottle of rum to empty the 5 m³ pit, which took the two-member team five hours.

The following table summarizes the information on the three teams offering pit emptying services.

#	No. of Indiv.	Professions	Pits Emptied/ Year	Rates
1	4	Municipal employees performing various tasks (electricians, masons, plumbers, pit emptying, etc.)	Rare	NA
2	2	Masons, harvesters, dockers, pit emptying	3 to 4	MGA 20,000 to 60,000
3	3	Hog slaughtering, plumber, pit emptying, carpenter	12 to 24	MGA 40,000 to 120,000

The Pit Emptiers



Most of the men working to empty pits are fathers who are daily wage workers (masons, harvesters, dockers, etc.). They have completed at most grade 9.

While a few of them have a regular job (such as butcher, joiner, or municipal employee), the others have to go out early every day to find a job.

Most of them request a bottle of rum from their client when emptying a pit to be able to bear the unpleasant working conditions.

More than 30 pits are emptied in Ambositra each year. However, as their activity is informal, the pit emptying teams do not feel comfortable providing accurate information on the scope of their operations.

It is likely that other teams operate in Ambositra and that some households empty their pits on their own.

According to the teams, members engage in other activities such as harvesting, plumbing, carpentry, etc. It is important to note that while the daily income from these activities ranges from MGA 1,500 to 3,000 (\$ 0.75 to 1.50), a team member can earn up to MGA 40,000 (\$20) in three days by emptying a large pit (more than 6 m³).

3.2 Services Existing in Mahanoro

The municipality provides no sanitation services in Mahanoro but reported its plans to do so pursuant to its upgrade into an urban commune. However, to date no cesspit emptier operates in this area.

The disposal of fecal sludge constitutes a difficult problem for most households that use bucket latrines made of halved barrels (about 100 L) that must be emptied every four months. As the local population has a strong cultural revulsion against excreta, they resort to the services of third parties to empty their barrels. There seems to be only two people who are willing to empty pits and barrels in Mahanoro.

One of the workers explained that emptying pits creates such a social stigma against him that he is prohibited from being buried in the family tomb. As in Ambositra, the men who empty pits drink heavy amounts of alcohol and participate in other income-generating activities such as harvesting, dock unloading, charcoal making, etc.

The rates to empty pits are as follows:

Type of Pit/Barrel	Volume	Time required	Cost in MGA	Frequency
½ barrel	100 L	1 hour	5,000	1 per day in the dry season
1 barrel	200 L	2 hours	10,000	
Medium-size pit	> 1m ³	3 hours	30,000 to 50,000	About 1 per month

In Mahanoro, pit emptying services are offered by informal handymen who are more or less marginalized. In the past, one formal operator planned to launch a cesspit emptying service in Ambositra.

In both communes, the rates for emptying pits are high compared to the earnings of more traditional daily jobs. In Mahanoro, for instance, one day worked as a harvester pays MGA 2,500 (\$1.25) while emptying a bucket latrine of 100 L, which is done in one hour, pays MGA 5,000 (\$2.50).



Digging a trench for burying the sludge behind the toilet and shower unit in Alakamisy.

3.3 Local Techniques for Emptying Pits

In Ambositra, the pits to be emptied are usually simple pits or septic tanks, and the technique used depends on the outlets available. In some cases, the sludge is discharged into a drainage canal. More often, it is buried in trenches or holes dug nearby.

Given that this activity is illicit and in order to minimize the inconvenience to neighbors, the pits are emptied at night. The typical procedure for emptying a septic tank of 6 m³ and burying the sludge is as follows:

	Tasks	Duration
Day	Dig the trench/hole for burying sludge	2.5 to 3 hours
Night	Take off the slab Empty the pit (transferring from pit to trench) Put back the slab and seal it with cement Fill in the manhole Wash the equipment (at the river) Clean the area	5 to 6 hours
Total Duration		7.5 to 9 hours

When it is not possible to dig a trench or a hole, the sludge is discharged into drainage canals. As transportation from one place to another is involved in this case, the operation may take much more time and may have to be spread over several nights (up to three).



Digging the trench for burying sludge

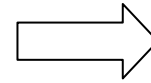
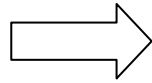

Removing the sludge

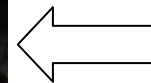

Transferring the sludge

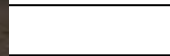

Discharging in a manhole or burying in a trench

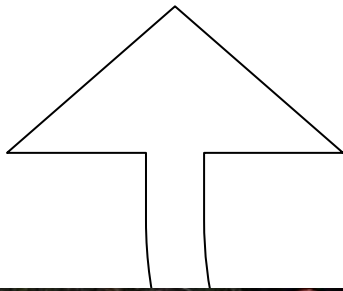

Cycle for Manually Emptying a Pit from 7.5 to 9 hours

Discharging sludge into drainage canals can cause serious maintenance problems to the municipality that has to regularly dredge the canals to remove sludge, which is left to dry before being taken to the municipal landfill.



Dredging of drainage canals and sewers by the municipality’s mobile teams (Ambositra)

The work is done using basic tools such as ladders, pails, shovels, and wheelbarrows.

In Mahanoro, the general practice is to bury sludge near the latrines. The sandy soil in the region makes it easy to dig a trench to bury sludge. If it rains, one has to wait two days before digging. The operation is done by day and does not take more than one hour for a 100 L bucket latrine.

The operation does not require any material when it consists of emptying a bucket latrine. For a pit, the client provides a pail.

The main problems mentioned by the men who empty pits are summarized in the following table.

Ambositra	Mahanoro
<ul style="list-style-type: none"> - No sturdy equipment - No protective equipment (gloves, boots, etc.) - Hard work and lack of sleep - Itching at feet even several months after - Complaints by neighbors: “We have to burn tires to mask the smell” 	<ul style="list-style-type: none"> - No suitable tools or equipment for digging - Social stigma: prohibited from being buried in the family tomb and taunted by children

Fecal sludge removal services are available in Mahanoro and in Ambositra. Unfortunately, they present serious health hazards for those who perform the operation as well as for the population.

By moving the sludge just a few meters away from where it was collected, the traditional operation of pit emptying does not provide a real solution at a citywide level. The main areas for improving the service include:

- Making the pit emptying operations more hygienic
- Disposing the sludge out of the town

The challenge will be to keep costs at an affordable level once transportation costs are factored into what is usually paid for traditional pit emptying.

In regard to the toilet and shower units, the poor logistics available to the traditional pit emptying teams and their low capacity call for other operators to step in that have the capacity to coordinate operations, manage vehicles, and commit to quality of services.

The market for such services is large enough, and the willingness to pay for such services is high enough, in both communes to motivate a competent private operator (toilet and shower unit manager, transporter, owners of hardware stores, etc.). In Mahanoro, the issue will be whether people are willing to invest their time and their social image in a business related to excreta.

4. Appropriate Systems Proposed for Managing Sludge from Public Toilets

The objective is to design a system that is effective, hygienic, affordable, environmentally friendly, and sustainable for emptying pits and processing the sludge from the public toilets built/rehabilitated by C-Change/HIP in the communes of Ambositra and Mahanoro.



The present study explores the issue of management of sludge emptied from the toilet and shower units built/rehabilitated by C-Change/HIP. The results may be used for the management of sludge from other public toilets as well as private facilities, though additional data will be required (statistical, analysis of sludge, etc.) and additional reflection will have to occur to take into account differing logistical needs and impacts.

4.1 Alternative Technologies

When it is not possible to use conventional methods (cesspit emptier and treatment plants), alternatives must be developed for each of the following three steps:

- Removal/transfer
- Transportation
- Disposal/treatment

Removal/Transfer

This step consists of taking out the sludge accumulated in the pit and carrying it to a vehicle that will transport it to the final disposal/treatment site.

Practically speaking, the selection of a technique depends on the accessibility of the pits and the sludge's consistency.

To address the issue of poor accessibility of urban neighborhoods, several technologies are under development. In March 2011 the Water Research Commission in Durban presented highly promising technologies:

For public toilets fitted with septic tanks, the **Gulper system** is suitable for semi-liquid sludge. The system avoids the need for one person to go into the pit and allows for pumping out the sludge at a flow of 30 L per minute (Pollution Research Group, Durban). While the system is effective, its activation requires a lot of strength.

Alternate Removal Technologies



Gulper



EVAC



Manual pit screw auger



Power-operated pit screw

EVAC is a light vacuum reservoir system that is power-operated and designed for pits with liquid sludge. No indication on its flow is available because it is still under development.

The **Pit screw auger** is designed for solid sludge, such as the sludge found in open pits. It uses an auger and its flow ranges from 7 L to 20 L per minute.

Transportation

Improving sludge management entails developing a site for disposal/treatment, which in turn entails transportation.

Given that the transportation of sludge and the related costs are complex issues, the distance from the pits to be emptied to the disposal site is a determinant for the entire process.

Municipalities have to take into account environmental and logistical constraints as a whole to identify the disposal site that will be the most appropriate in the long run.

Disposal/Treatment

Sludge from septic tanks is highly polluting and contaminated (up to 100 to 1,000 worm eggs per gram of sludge, according to the Pollution Research Group, Durban). Discharging it into the environment requires special precautions.

Processes that are suited for countries in the southern hemisphere are being researched. The Swiss Federal Institute of Aquatic Science and Technology has successfully experimented with planted beds that are especially effective under tropical conditions.

To date, the most functional techniques for treating sludge from public toilets in developing countries include:

- Co-composting with domestic waste
- Planted or unplanted drying beds

An overview of the various options may be downloaded from the Swiss Federal Institute of Aquatic Science and Technology website at: http://www.eawag.ch/forschung/sandec/publikationen/ewm/index_EN.

Also at an experimental stage, the **solar sludge oven** could offer a rustic solution in Ambositra given the fairly low amount of sludge produced by the two toilet and shower units and sunny conditions in the region (an annual average of 5,000 Wh/m², SODA 2005).

Finally, though it may appear basic, burying the sludge in trenches for planting can be a limited solution but suited to the context of the study communes where much space is available, cultural revulsion to feces is strong, and technical capacity is low.

Cesspit Emptiers



Cesspit emptiers of a capacity of 9 m³ remain the standard for emptying septic tanks in urban areas as they ensure both removal and transportation of sludge. However, these vehicles are scarce in Madagascar.

The main disadvantage of these trucks is that they cannot access all the pits, especially in narrow streets, their reach being less than 30 m.

Maintenance is a crucial aspect of the operation of a cesspit emptier. They are usually purchased as secondhand vehicles and require much attention to prevent breakdowns.

Most trucks are manufactured in North America or Europe, and this makes it difficult to find spare parts as well as mechanics for repairs. On the other hand, a brand new truck is very expensive at almost \$120,000.

Given these reasons, the use of a cesspit emptier is not suggested under this study though it is a desirable choice for the two communes.



Experimental sludge oven



Dried sludge



Dried and crushed sludge



Emptying barrels



Sludge discharged



Eucalyptus plantations (2.5 years later)

Co-composting has to be discarded as an option because of the strong cultural revulsion against the use of human excreta in farming in Madagascar. In addition, introducing this practice in Ambositra may be harmful to the reputation of the compost produced by the International Youth Chamber.

On the other hand, the hygienic aspect of dried sludge produced in solar ovens may work in favor of the adoption of sludge for different purposes.

4.2 Technical Options Proposed

4.2.1 Basis for the Design

The Options Suggested are Based on the Data Collected During the Assessment:

	Ambositra	Mahanoro
Number of C-Change/HIP public toilets	2	1
Average pit size	6 m ³	12 m ³
Consistency of sludge	Thick, unstable	
Frequency of emptying	Every 8 months	Every 15 months
Accessibility of pits	Stairs or narrow streets	Narrow street (width less than 2 m)
Average distance to disposal site	2.5 km	2.5 km
Surface area of disposal site	More than 2,000 m ²	More than 3 ha
Current cost of emptying (6 m ³)	From MGA 50,000 to 120,000	From MGA 30,000 to 50,000
Current time needed for emptying	≈ 9 hours (3 hours: digging	≈ 9 hours





(6 m ³)	trench) 2 or 3 workers	1 worker
Number of workers identified	9	2
Potential private operators	2 (manager in Sabotsy + other)	1 (manager of toilet unit)
Vehicles available	Trucks, pick-ups, motorcycles, carts	Tractor, pick-ups, motorcycle
Organizational capacity (municipality and pit emptying teams)	Fair	Very weak
Social and cultural aspects	Work to be done by night	Stigma against men involved in this work

4.2.2. Removal of Sludge

Though more tools are used in Ambositra, the practices to remove and transfer sludge are about the same in the two communes.

In terms of weight, 6 m³ of sludge weighs 8 metric tons. Thus, the energy required and the health hazards incurred while emptying the pits of the toilet and shower units are huge. Adequate manual labor (one individual per m³ of sludge), with the right equipment and training on the basic rules of hygiene, should be provided.

The logistics of the sludge removal technique proposed is summarized in the following table:

Pit	Hand labor	Emptying Kit*	Characteristics
 <p>6 m³</p>	 <p>x 6</p>	<ul style="list-style-type: none"> - 2 gulper pumps - 2 cleaning shovels with extensions - 2 rakes - 2 pitchforks - 6 protective outfits - 1 toolbox - 1 hauling cart of 120 L or 1 hauling container of 240 L fitted with wheels 	<p>Duration: 2 - 3 hours (vehicle <100 m)</p> <p>Gulper flow ≈ 30 L/min</p> <p> Economical Access to all sites</p> <p> Pumping arduous Transfer into another container required</p>
	MGA 120 -150,000	MGA 2,900,000 **	

* Kits for emptying pits of 6 m³ or more, detailed in a list in Annex 2

** Variations can be considered

Tools specifically designed for manually emptying the pits can be developed. Though they may be rustic, they are essential to the effectiveness of emptying operations:

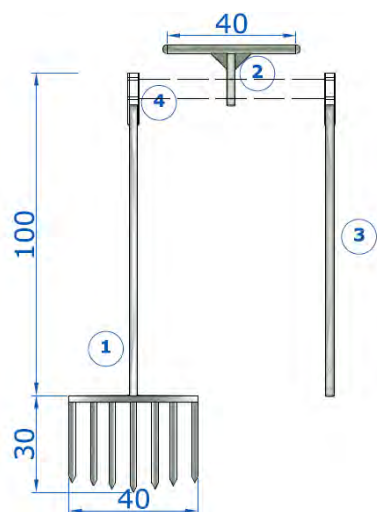

Mixer with extensions

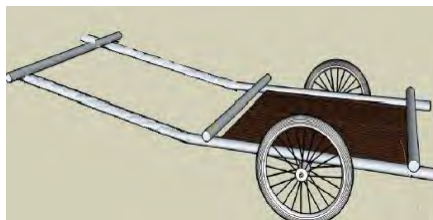

Hauling racks for transferring jerry cans

The removal technique will result in two types of improvements:



- *More effective: less effort will have to be made and the work is completed more quickly*
- *Better hygiene: contact with sludge is limited and the workers are protected.*

4.2.3 Transportation of Sludge

The two communes have designated areas for disposing the sludge at an average of 2.5 km from the toilet and shower units built/rehabilitated by C-Change/HIP. The use of vehicles must be considered when emptying these facilities whose capacity is more than 6 m³.

Smaller scale pit emptying (1 to 2 m³) could use systems drawn by men or animals. In Mahanoro, where the terrain is flat, rickshaws could be used for transporting the bucket latrines.

Very limited choices of vehicles exist in Mahanoro, and it is difficult to convince transporters to load fecal sludge onto their vehicles. Given the size of the toilet and shower unit built/rehabilitated by C-Change/HIP (12 m³), a 3 m³ trailer hauled by a tractor would be necessary; we have found an owner of a tractor who is willing to do this.

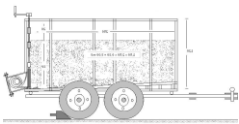
Rickshaw		Peugeot 404 pick-up	Truck of 52cv	Trailer of 3 m ³
				
Payload	250 – 300 kg	1 T	2.5 T	4.9 T
Number of vehicles (1)	-	2	2	1 tractor + 1 trailer
Number of two way	-	6	3	2

trips				
Number of jerry cans ⁽²⁾	-	30	60	8
Duration	-	5 h	4 h 30	4 h 30
Cost ⁽³⁾	-	MGA 150,000	MGA 180,000	MGA 140,000
Cost of equipment ⁽⁴⁾	MGA 650,000	MGA 1,200,000	MGA 2,400,000	MGA 3,520,000

(1) Number of vehicles required to empty a pit of 6 m³. (2) Jerry cans of 60 L used for handling the sludge. Their number will depend on the vehicle used. (3) Transportation rental for sludge to the disposal site (2.5km) by night. (4) Cost of procuring the jerry cans + trailer.

Except for the 3 m³ trailer, the proposed vehicles will transport sludge in plastic jerry cans of 60 L for easier handling and for better hygiene. In practice, the number of jerry cans will range from 8 to 60 depending on the vehicles used.



Even though several trips will be required when using a Peugeot 404 pick-up, this would allow a reduction in the number of jerry cans. The 3 m³ trailer will make unloading easier and will require only eight jerry cans.

It will be necessary to store and wash the containers. The idea of transporting sludge in disposable plastic bags, such as those used for packaging fertilizer, was considered at some point, but this option was discarded due to the excessive cost (MGA 2,500 or \$1.25 per 60 L bag).

Several types of vehicles can be used. The choice will depend on logistical considerations (storage space for the jerry cans, management of the trips, etc.), the availability of transporters in the field as well as the rates they will propose.

Subcontracting sludge transportation aims to minimize initial investments as well as avoid the issue of maintaining vehicles, which is the main cause of concern in managing pit emptying services.

4.2.4 Disposal/Treatment Sites

In Ambositra, the municipality suggested dumping domestic waste in the landfill, located 2 km north of downtown. The site can be accessed by motor vehicle, and more than 5,000 m of sludge could be disposed of at this site.



Overall, it seems appropriate to use this site for the following reasons:

- It is already dedicated to sanitation
- There is a lot of space available
- There are no wells downstream
- The groundwater is more than 10 m deep

However, it should be noted that there is a hamlet 200 m from the site.

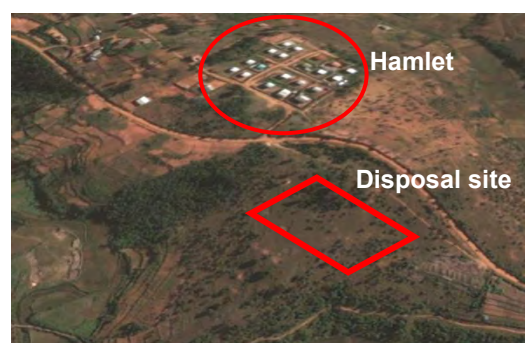

In Mahanoro, the mayor suggested using an uncultivated plot of more than 3 ha located 3 km from downtown. The site seems to be suitable because of its easy access and lack of nearby human dwellings. However, aerial photos of the zone suggest land could be available at a closer distance, which would facilitate transportation.

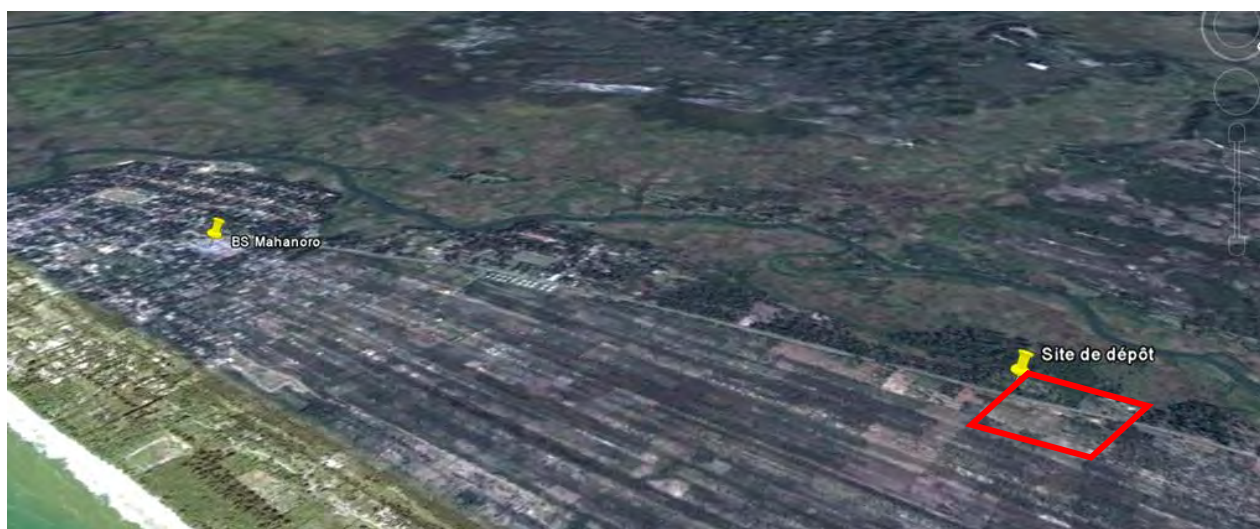

The selection of a disposal/treatment site depends on the amount of sludge. In our case, the potential sites suggested by the mayors seem to be suitable. Ultimately, the decision will fall to the municipal council, which will also have to take into account the need for sludge disposal in terms of the town's scale.

4.2.5 Disposal/Treatment Techniques

Technique 1: Planted Burying Pits or Trenches

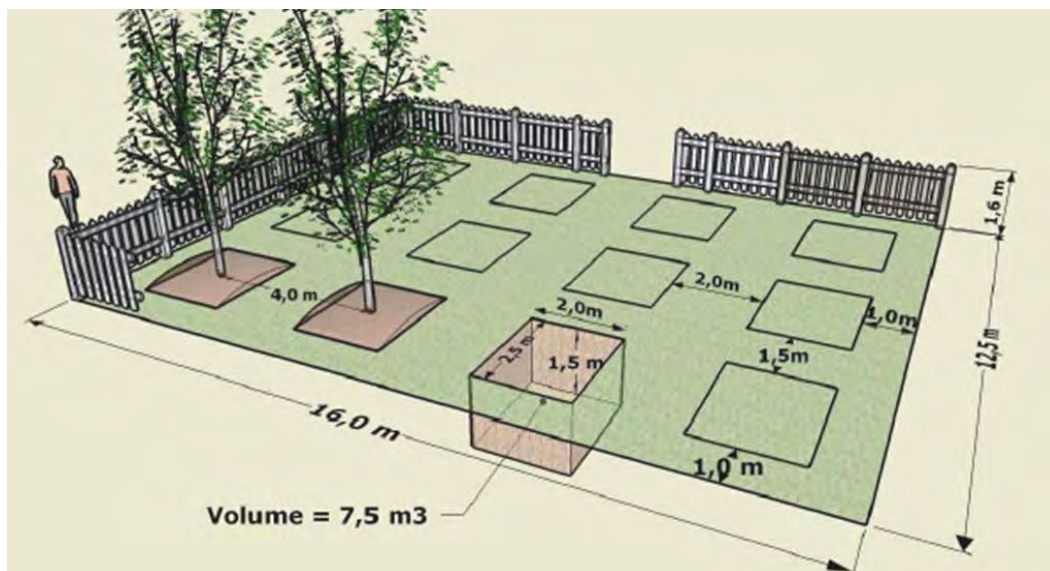

Plan for developing a disposal site in Ambositra

Use:	<p>Treatment of sludge from the toilet and shower unit that was built/remodeled by C-Change/HIP</p> <p>Treatment of sludge from a pit emptying service extended to all facilities</p>
Description:	<p>The disposal sites are cleared and structured in a grid-like system where pits of a capacity of 7.5 m³ and 1.5 m in depth are aligned.</p> <p>The site is used starting from the back where the pit(s) are dug the day before the toilets are emptied. The initial development can be completed in three (3) weeks with no need for specialized labor.</p> <p>With trenches 1.5 m deep, the site in Ambositra (5,000 m²) could accommodate 5,625 m³ of fecal sludge (assuming that 75 percent of the surface area is used), i.e., sludge from 937 public toilets or from 2,812 latrines of 2 m³. In Mahanoro, the disposal site of more than 3 ha offers immense storage space.</p> <p>A secure site of 200 m² could be enough in the first stage. Its expansion must be planned ahead as the site is used.</p> <p>Recent studies by the University of Durban showed that this technique is safe for ground water and that the sludge is beneficial to the growth of trees.</p>
Costs:	<p>A secure space of 200 m² with an access road and 2 pits: MGA 1,267, 650 (\$633)</p> <p>The cost of an additional trench or pit of 7.5 m³: MGA 20,000 (\$10)</p>
Advantages:	<p>Simple to use</p> <p>No nuisance for neighbors in terms of smell or aesthetic</p> <p>Flexibility: no restriction on the amount or the characteristics of sludge</p>
Disadvantages:	<p>Soil and shallow groundwater pollution</p>

Technique 2 : Solar Sludge Oven (experimental)	
Use:	Treatment of sludge from the toilet units that were built/remodeled by C-Change/HIP in Ambositra
Description:	<p>The solar sludge oven is based on the idea of the solar oven box, invented by a Swiss man named Horace de Saussure.</p> <p>The device is made up of an insulated box covered with glass that sits at a 45 degree angle. The temperature inside rises as the box is exposed to sun rays. When well insulated, the inside temperature can reach 180°C.</p> <p>Sludge ovens made of bricks and cement with an individual capacity of 6 m³ could be built on the disposal site as part of the sludge treatment in Ambositra. The oven would be half-buried and insulated and would be covered with removable transparent roofing sheets. Wool wicks would be placed between the roofing sheet and the box to ensure thermal isolation and allow for draining evaporation that runs down the roofing sheet's slope.</p> <p>The sludge is loaded into the oven, which is closed once full. As the oven heats, depending on the degree of insulation, the sludge will dry over several months until the pits are emptied again. By then, the dry residual sludge has become hygienic and can be buried under a thin layer of soil or can be used for soil improvement in the neighboring orchards.</p> <p>This equipment is aimed at reducing the amounts of sludge and biological contaminants put into the soil. If the sludge could be properly dried, this may convince local farmers to use human excreta in their plots.</p>
	 <p><i>Box type solar oven</i></p>   <p><i>Solar sludge oven</i></p>
Costs:	MGA 2,300,000 (\$1,150) for two ovens of 6 m ³
Advantages:	<ul style="list-style-type: none"> Sludge becomes hygienic Simple to use Amount of sludge is reduced Low environmental impact Use of the dried sludge can be considered
Disadvantages:	<ul style="list-style-type: none"> Limited processing capacity: (only ≈12 m³ per 8 months) Cost is higher compared with burial pits or trenches May generate foul smell

Technique 3: Drying Bed

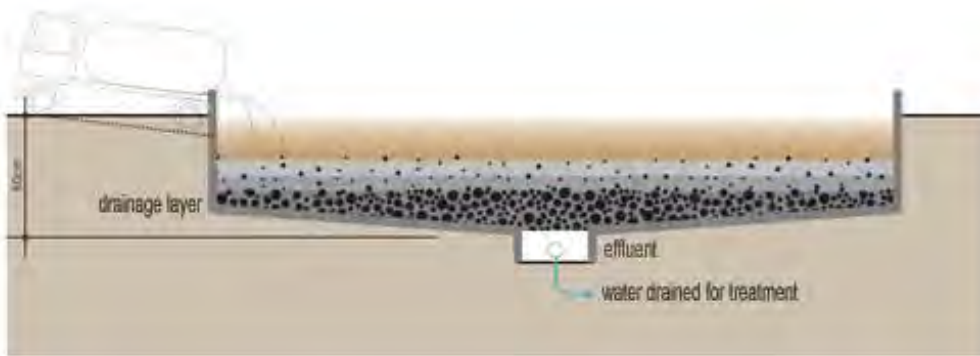

Figure showing the principle of a drying bed

<p>Use:</p>	<p>Treatment of sludge from a pit emptying service extended to all facilities</p> <p>This technique can be applied to public toilets <u>only</u> when the sludge from these facilities can be mixed with sludge from private homes (Strauss).</p>									
<p>Description:</p>	<p>An unplanted drying bed is simple and permeable, and it allows the liquid portion of the sludge to be loaded onto it. The sludge then drains and evaporates. About 50 percent to 80 percent of the sludge’s volume percolates as liquid. However, the sludge is not stabilized. The bottom of the drying bed is fitted with holes that allow leachate to drain. Above the drains, layers of sand and gravel bear the sludge and allow the liquid to run into the drain. The sludge must be spread in layers of less than 20 cm to dry effectively.</p> <p>Once the sludge is dry, it must be separated from the sand layer and removed. The effluent collected in the drainage pipes must also be properly treated. The upper sand layer must be 25 to 30 cm thick because a certain amount is lost each time the sludge is manually dredged.</p> <p>The advantage of using a drying bed compared to the previous techniques is that it allows for treating more sludge per surface unit. It is less advantageous when it is not possible to use the treated sludge in the surrounding environment.</p> <p>Experts recommend a dimension of 200 kg MS/m²/year under tropical conditions, which gives the following bed surfaces a space to process 6 m³ and 12 m³ of sludge per month:</p> <table border="1" data-bbox="386 1465 945 1663"> <thead> <tr> <th>Amount emptied per month</th> <th>Amount of sludge per year</th> <th>Surface area of drying bed* m²</th> </tr> </thead> <tbody> <tr> <td>6 m³</td> <td>72</td> <td>24</td> </tr> <tr> <td>12 m³</td> <td>144</td> <td>48</td> </tr> </tbody> </table> <p>* Sludge density of 1.3g/l. 50g MS/kg</p>	Amount emptied per month	Amount of sludge per year	Surface area of drying bed* m ²	6 m ³	72	24	12 m ³	144	48
Amount emptied per month	Amount of sludge per year	Surface area of drying bed* m ²								
6 m ³	72	24								
12 m ³	144	48								
<p>Costs:</p>	<p>One bed of 24 m²: MGA 8,000,000 (\$4,000)</p>									
<p>Advantages:</p>	<p>Partial treatment of sludge and water Amount of sludge is reduced</p>									
<p>Disadvantages:</p>	<p>Requires mixing sludge from public toilets with other sludge Generates smell and dredging is quite difficult</p>									



View of a drying bed

4.2.6 Technical Process Proposed

Based on the technical options reviewed, the technical processes that can be considered for managing the sludge from the toilet and shower units are summarized as follows:

Removal/Transfer	Transportation	Treatment/Disposal	Time	Cost **	Comments
	Team of 3 persons + cesspit emptier of 9 m ³ *		5h	Emptying: MGA 600,000	Not available Site nonaccessible
Team of 6 people Manual labor : MGA 150,000 1 pit emptying kit MGA 2,900,000	2 x 404 pick-up of 1T + 30 jerry cans transportation: MGA 150,000 jerry cans: MGA 1,200,000	Burial site 2,000 m ² (MGA 1,267,650)	5h	Emptying: MGA 300,000 Equipment: MGA 5,367,650	Minimal management of sludge
	2 x trucks of 2.5T + 60 jerry cans transportation: MGA 180,000 jerry cans: MGA 2,400,000		4h30	Emptying: MGA 330,000 Equipment: MGA 6,567,650	
	Truck + trailer 3 m ³ transportation: MGA 140,000 trailer + jerry cans = MGA 3,520,000		4h30	Emptying: MGA 290,000 Equipment: MGA 7,687,650	
	2 x 404 pick-up 1T + 30 jerry cans		5h	Equipment: MGA 6,400,000	
	2 x trucks 2.5T + 60 jerry cans	Burial site 200 m ² (MGA 1,267,650) + Solar ovens of 6 m ³ (MGA 2,300,000)	4h30	Equipment: MGA 7,600,000	Experimental treatment of sludge from public toilets and minimal management of other sludge
	Truck + Trailer of 3 m ³		4h30	Equipment: MGA 8,720,000	
	2 x 404 pick-up 1T + 30 jerry cans		5h	Equipment: MGA 12,100,000	
	2 x trucks 2.5T + 60 jerry cans	Burial site 2,000 m ² (MGA 1,267,650) + Drying bed of 24 m ² (MGA 8,000,000)	4h30	Equipment: MGA 13,300,000	Treatment of sludge from public toilets and other sludge
	Truck + trailer of 3 m ³		4h30	Equipment: MGA 14,420,000	

Figures in relationship with emptying a pit of 6 m³

* As an indication based on the prices in Antananarivo for accessible pits

** Investment without the purchase of a vehicle. The cost of emptying pit does not include the operators' profit margin



The options involving the 404 pick-up, the 2.5T truck, and the oven are not suited to Mahanoro where the pit is too large and insulation insufficient.

4.2.7 Financial Aspects

Costs of the Service

From a commercial point of view, the service's cost structure could be as follows for emptying a 6 m³ pit, using a Peugeot 404 pick-up:

Cost of the Service (Emptying a 6 m³ pit), Transportation Subcontracted (Scenario 1)

Item	Qty	U.P. Exclusive of Tax	Amount in MGA
Hand labor	6	25,000.00	150,000.00
Transportation	6	25,000.00	150,000.00
Amortization of equipment (100 emptying operations)	1	41,000.00	41,000.00
		Subtotal	341,000.00
		25% margin	85,250.00
		TOTAL	426,250.00

With the pit emptying operation lasting about five hours and costing about MGA 430,000 (US \$220) to remove and treat the sludge from a 6 m³ pit, the alternative systems for emptying the pits could result in the development of a profitable operation.

However, it should be noted that pits of 6 m³ can be emptied for less than MGA 100,000. Without regulations, it will be very difficult to promote a new service that is four times more expensive than informal services.

In the event that the service provider owns the vehicle that would transport the sludge, the transportation cost may be significantly cut and the profit would increase accordingly (a profit margin up to 50 percent), as described in the following table:

Cost of the Service (Emptying a 6 m³ Pit), Service Provider Owns the Vehicle Used (Scenario 2)

Item	Qty	U.P. exclusive of tax	Amount in MGA
Hand labor	6	25,000.00	150,000.00
Fuel	1	15,000.00	15,000.00
Maintenance of vehicle	1	20,000.00	20,000.00
Amortization of equipment (100 emptying operations)	1	41,000.00	41,000.00
		Subtotal	206,000.00
		50% margin	103,000.00
		TOTAL	309,000.00

In the intervention communes, where 6 m³ of sludge has to be emptied every eight months, as in the case of Ambositra, and 12 m³ of sludge every 15 months in Mahanoro, the unit managers will have to designate MGA 40,000 to 50,000 per month depending on the scenario.

As previously demonstrated, the revenue generated by the toilet and shower units should cover the cost of improved pit emptying services. In practice, the distribution of this cost between the municipality and the manager remains to be determined.

Investment

In general, the cost of the equipment is very high compared to the operational revenue of the toilet and shower units:

Price of Some Pieces of Equipment, as an Indication

Item	U.P. in MGA	U.P. in US \$
Pit emptying kit	2,900,000	1,487
Jerry cans for 404 pick-up	1,200,000	615
Trailer with tank	3,520,000	1,805
Burial site in Ambositra	1,267,650	650
Burial + solar oven	5,200,000	2,667
Burial + drying bed	10,900,000	5,591
2.5T truck (new)	26,400,000	13,541
Peugeot 404 pick-up (secondhand)	6,000,000	3,077

In practice, it may be advisable to entrust the development of the burial sites to the communes and in return provide them with the pit emptying kits needed to launch a pilot service (exclusive of the vehicle).

4.3. Structure of a Sludge Management Service

Article 41 of the Water Code stipulates: “Urban and rural communes are the owners and contracting authorities for the collective sewage system located in their respective territory. They exert this duty through the Municipal Council.”

As such, the municipalities must develop a municipal sanitation plan that specifies how sludge should be managed. The service for managing sludge from toilet and shower units should be included in this plan.

Which Service?

In the two communes, the mayors indicated that they would prefer delegating the management of sludge from the public toilets to service providers rather than to one of their technical departments.

However, with one or two pit emptying operations per year per commune, the maintenance of C-Change/HIP toilet units is not an activity that is large enough to attract private operators. In addition, the improved pit emptying techniques must be regularly practiced to be mastered.

- The commune in Ambositra has eight public toilets. Assuming that these are managed and used as C-Change/HIP’s two toilet and shower units and adding in the needs of hotels, healthcare institutions, and private homes for pit emptying services, a profitable activity may be initiated.
- In Mahanoro, no other public toilet units or similar structures that have large pits need to be regularly emptied. However, there is a sizeable demand for bucket latrine disposal services among households, which would pay regularly for emptying.

The management of sludge from the toilet and shower units in Ambositra and Mahanoro requires the development of a specialized private service, whose main business will be based on clients yet to be identified.

Which Service Provider(s)?

Improved pit emptying practices require service providers to transport the sludge out of town and treat it properly as part of the disposal process.

During the assessment, the toilet and shower unit managers interviewed expressed interest in expanding their business to include this service. A competent pit emptying team in Ambositra also expressed interest.

In practice, an information session should be held in each commune to identify potential providers. Through this consultation, the terms and conditions of the collaboration could be defined (distribution of the initial investment, need for technical support, etc.) and a call for expression of interest could be sent out.

The collaboration can be opened to a large array of service providers because the proposed systems for emptying the pits and disposing and treating sludge are fairly rustic.



The managers of toilet units are interested in the sanitation business.

What will be the Commune’s Role?

First of all, the commune should encourage the population to adopt improved pit emptying practices. Its role will vary according to negotiations with the selected service provider(s). It may develop the burial site and will have to monitor and assess the activities and results of the service provider(s).

What would be the Service’s Structure?

The service’s structure will depend mainly on the proposals submitted to the commune and the ensuing negotiations. Overall, it may look similar to the following illustration:

Commune
Making pit emptying equipment available
Issuing approval, monitoring and assessment
Granting authorization for posting advertisements



Service provider 1, 2,
Payment of a fee
Emptying toilet unit pits at an agreed rate
Maintenance of the disposal/treatment site
Maintenance and repair of equipment
Financial reporting



Clients
Private – Public toilet units



Subcontractor



Pit emptying teams



Transporters

4.4. Sludge Management Service for Private Latrines

While the assessment focused on the sludge from the toilet and shower units, it also noted the feasibility of a service targeting individual households. A household survey would help quantify the amount of sludge to be emptied per year and the household's capacity to pay for improved pit emptying services. Several low cost options may be developed in each commune. In the event that sludge is buried, two options for services may be considered as shown below:

Ambositra: Emptying Pits from Private Latrines (2 m³)

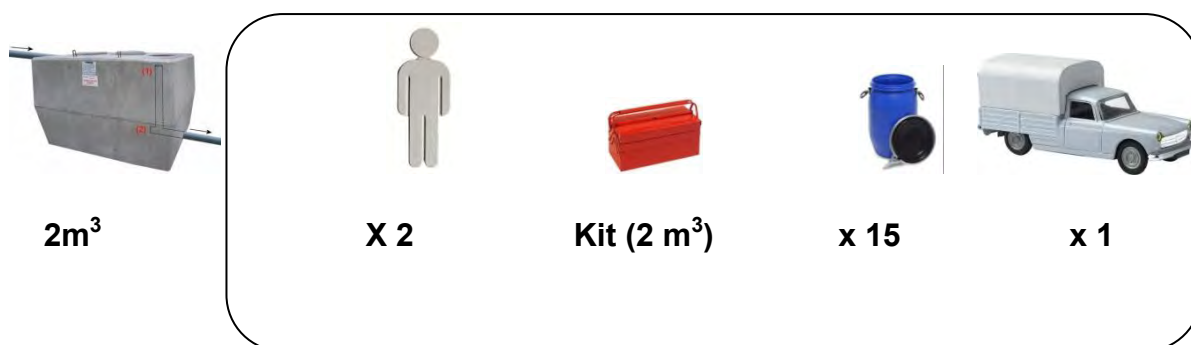

Cost of Equipment:

 = 3h30

Item	U.P. In MGA
Pit emptying kit 2 m ³	1,300,000
Barrels of 60 L x 15	600,000
TOTAL	1,900,000

Cost of Service:

Item	Qty	U.P. in MGA	Amount in MGA
Manual labor	2	20 – 25,000	40 – 50,000
Transportation	1	15 – 50,000	15 – 50,000
Amortization of equipment (100 emptying operations)	1	19,000	19,000
		TOTAL	74 – 119,000

Direct costs involved in the service would range from MGA 75,000 (\$37.50) to MGA 120,000 (\$60), depending on whether the service provider owns the vehicle or not. The cost of service to a household would be about MGA 120,000 on average, with a profit margin of 25 percent for the service provider.

Mahanoro: Emptying Household Bucket Latrines (100 L)



= 6

Cost of Equipment:

Item	U.P. in MGA
Cart	864,000
TOTAL	864,000

Cost of Service:

ITEM	QTY	U.P. in MGA	AMOUNT in MGA
Manual labor	2	20 – 25,000	40 – 50,000
Amortization of equipment (100 emptying operations)	1	9,000	9,000
TOTAL			49 – 59,000

Direct costs involved in the service would range from MGA 50,000 (\$25) to MGA 60,000 (\$30) depending on the cost of labor.

In this case, having an operator in charge of coordinating the service seems to be less essential as the required equipment is basic. The cost to households would range from MGA 8,500 (\$4.25) (without an operator) to MGA 12,500 (\$6.25) (with an operator applying a profit margin of 25 percent).

A household survey should be conducted to explore in detail the economic feasibility of an improved pit emptying service for individual households. Such services look promising.

The services could be developed by the existing pit emptying teams that have little means and only some manual labor, and they could be extended to a large portion of the population.

However, it should be noted that such services would require setting up a sludge treatment service whose capacity should exceed the required capacity to treat the sludge from public toilets.

Annex 1

Frequency of Pit Emptying

Based on Francey's formula:

Where:

N	Number of users defecating*	= number of users defecating/ 1.5.																							
Ve	Amount of water discharged in pit /d	= 5x nb of users urinating + 5x nb of users defecating																							
A	Accumulation	80 L/person/year (Pollution Research Group 2011)																							
F	Frequency of emptying	Interval between two emptying operations																							
Fe	Environmental factor**	<table border="1"> <thead> <tr> <th rowspan="2">F value</th> <th colspan="3">AMBIENT TEMPERATURE</th> </tr> <tr> <th>>20°C</th> <th>>10°C</th> <th><10°C</th> </tr> </thead> <tbody> <tr> <td>NUMBER OF YEARS BETWEEN EMPTYING OPERATIONS</td> <td></td> <td></td> <td></td> </tr> <tr> <td>1</td> <td>1.3</td> <td>1.5</td> <td>2.5</td> </tr> <tr> <td>2</td> <td>1.0</td> <td>1.15</td> <td>1.5</td> </tr> <tr> <td>3</td> <td>1.0</td> <td>1.0</td> <td>1.27</td> </tr> </tbody> </table>	F value	AMBIENT TEMPERATURE			>20°C	>10°C	<10°C	NUMBER OF YEARS BETWEEN EMPTYING OPERATIONS				1	1.3	1.5	2.5	2	1.0	1.15	1.5	3	1.0	1.0	1.27
F value	AMBIENT TEMPERATURE																								
	>20°C	>10°C	<10°C																						
NUMBER OF YEARS BETWEEN EMPTYING OPERATIONS																									
1	1.3	1.5	2.5																						
2	1.0	1.15	1.5																						
3	1.0	1.0	1.27																						

* The traditional basis for dimensioning refers to resident users. The average number of defecations per inhabitant is set at 1.5, which means 1 resident user represents 1.5 public toilet users, in terms of depositing feces in the pit.

** The calculation is iterative: Fe is first estimated then calculated based on the calculation of F.

Based on the records of the toilet and shower unit operations in January 2011:

		Sabotsy	Mahanoro
Total amount		5.3	12.8
N	Number of people	163.0	147.0
	- WC	90.0	120.0
	- Urinal	69.0	20.0
	- Shower	4.0	7.0
Amount of water	Volume / person / day	5.4	7.6
	- WC	5.0	8.0
	- Urinal	5.0	1.0
	- Shower	20.0	20.0

* N.B. : The water from the shower bypasses the pit.

The frequency of emptying should be as follows:

WC	Volume (m³)	Number of users per day	Frequency of emptying (months)
Sabotsy	5.3	60	7.5
Alakamisy*	6.7	60	9.8
Mahanoro	12.8	80	15.1

* The level of use is assumed to be equal to that in Sabotsy as there are no data available.

Annex 2

Pit Emptying Kit: Components and Costs

Item	Qty	U.P. E.T. in MGA	AMOUNT E.T. in MGA
Protective eyewear Evarena	6	13,333.33	79,999.98
Mask M3+2RCHRA2	6	85,750.00	514,500.00,
glove PVC VRT Dbl End	6	12,750.00	76,500.00
Rubber boots .Trav..No	6	45,083.33	270,499.98
Blue overall TT	6	41,666.67	250,000.02
Raincoat T 1PC VRT	6	18,166.67	109,000.02
Headlight	6	9,166.67	55,000.02
Large shovel without handle	2	5,416.67	10,833.34
Handle 1st Choice	2	2,666.67	5,333.34
4-Prong Pitchfork	2	3,333.33	6,666.66
Handle 1st Choice	2	2,666.67	5,333.34
Rake + Handle	2	3,333.33	6,666.66
Handle 1st Choice	1	2,666.67	2,666.67
Mason's flat chisel	1	4,833.33	4,833.33
Sledge hammer 4Kg EMOM91	1	86,250.00	,86,250.00
Jumper bar. 1,5m	1	21,666.67	,21,666.67
Trowel - type Br"	1	2,916.67	2,916.67
		TOTAL E.T.	1,508,666.70
		VAT 20%	301,733.34
		TOTAL	1,810,400.04
Item	Qty	U.P. E.T. in MGA	Amount E.T. in MGA
Hauling cart 120l	1	144,952.00	144,952.00
Hauling container 240l	1	607,392.00	607,392.00
Dredging shovel	2	74,313.00	148,626.00
Mixer	1	87,875.00	87,875.00
Gulper	2	270,000.00	540,000.00
		TOTAL TTC	1,528,845.00

Annex 3

Interviews with the Pit Emptying Teams

Ambositra



1. Commune level mobile team: 4 people

SOLOFONIAINA Jules François. Married, with 5 dependent children. Performs several jobs (electrician, mason, plumber, etc.)

RALAIVAO Ernest. Married, 8 children including 5 dependents. Performs several jobs.

RAKOTOMALALA Jaonarivo. Married, 8 children, including 2 dependents.

RATOMBONIAINA Herinjato Armand. Married, 9 children, including 8 dependents. Performs several jobs.

Officially, the mobile team's job does not consist of emptying pits or dredging canals, but they actually dredge sewers four to six times per month (and transport sludge from the sewers to the temporary landfills).

Informally, they also empty pits from hospitals, offices, or private latrines but this is rare.

Problems: Dilapidated materials (shovel, fork, wheelbarrow, etc.) and no protective gear (gloves, overalls, etc.)

Health problems: None

Social problems: No problems in particular, except for the mindset of some people who, despite the sensitization, keep on throwing all kind of waste (garbage, bedpans, fetuses, etc.) in the sewers. When the agents try to reason with them, they hear responses, such as, "You are paid for this work!"

Task of the mobile team (as a team that performs several jobs):

- Garbage men
- Setting up platforms for events
- Gardeners
- Replacing guardians (municipal office, hospital, etc.)
- Sweeping public roads
- Roofers (repairs)

2. "Drinker" pit emptiers: 2 people

RIVO. He was busy at the time of the interview. He is the brother of Tal and Ramiza (the manager of the toilet and shower unit in Alakamisy)

RAZAFINDRAKOTO Martial (Tal). 45 years. Married (4 wives), 10 children, including 9 dependent, 1 grand-child

- Wife #1: at home, in the town of Ambositra. 5 children (all dependents), including 2 daughters and 3 sons.
- Wife #2: suburb of Ambositra. 3 children, including 2 dependents
- Wife #3: suburb of Ambositra. 1 child, dependent
- Wife #4: suburb of Ambositra. 1 child, dependent



Activities: Handyman (mason, harvester, docker, etc.)

Personal life:

- Completed only Grade 1 → is illiterate
- No problems between the four wives. All his children know each other.
- Income: most of it goes to Wife #1:
 - MGA 2,500/day as a harvester
 - MGA 3,000/day as mason, joiner, roofer, etc.
 - MGA 20,000 to 60,000 for emptying pits. 3 to 4 times/year (private septic tanks)

Problems encountered:

- Smell
- Lack of equipment and materials: gloves, lever, chisel, sledge hammer, boots, ladder, mask not only to keep foul smell away but to avoid swallowing sludge
- Health problems: itching on feet even several months after emptying the pits

Amount of work/ procedure:

- Setting the price based on the types and sizes of pits
- Digging the manhole (1.5m x 1.5m x 3m) on average in 2.5 to 3 hours
- Lifting the slab
- Emptying the pit (transferring to the trench or pit dug)
- Putting back and sealing the slab with cement
- Filling the manhole
- Washing the equipment and cleaning up
- Getting paid

Perception of the work: Not too hard, bearable

Ideas for improvement:

- Better equipment: gloves, lever, chisel, sledge hammer, boots, ladder, mask, coveralls

Washing of materials:

- In the premises of the pit's owner
- In a river or a canal

Ideas for improved pit emptying services:

- The worker should own the equipment and materials
- Otherwise, prefers the old method. This depends on the cost of renting the equipment

3. Pit emptiers who were formerly the managers of the toilet unit in Sabotsy: 3 people

RANDRIAMAHEFANIRIANA Zaharisoa. 48 years. Married, 4 children, all dependents.

Activities: Former manager of the toilet and shower unit in Sabotsy. He leads a pit emptying team of 3 people. He is serious. He does not drink alcohol and does not allow his colleagues to drink at work.

Professional record:

Completed grade 9 but did not obtain the related diploma

Income:

- MGA 1,000 to 2,000 for plumbing tasks
- MGA 2,000 to 3,000 per day for slaughtering 2 to 3 pigs for a butcher
- MGA 40,000 to 120,000 for emptying a pit (for the entire team)

RAZAFIMAHAIMOD Y Dominique. 40 years. Married, 3 children, all dependents. Cell 032 75 784 85

Activities: Performs several jobs

Professional record:

Completed grade 5 but did not obtain the related diploma

Income:

- MGA 5,000 to 6,000/day as a mason
- Farmer (tenant)
- MGA 40,000 to 120,000 for emptying a pit (for the entire team)

RANDRIAMARIMANANA Fenotiana. 20 years. Married, one young daughter. Cell 033 09 228 73

Activities: Carpenter

Professional record:

Completed grade 5 but did not obtain the related diploma

Completed grade 9 but did not obtain the related diploma

Income:

- MGA 50,000 for making a sideboard 1 or 2 times per month
- MGA 30,000 for making a sideboard 1 or 2 times per three months
- MGA 40,000 to 120,000 for emptying a pit (for the entire team)

Problems encountered:

- Equipment: not sturdy enough, breaks easily (pails), ladder needed
- Health problems: Pungent smell drying the throat. Burning pain and whitening of hands.
- Social: Neighbors complain about the smell during the pit emptying operation → burn tires.

Work load:

- 1 to 3 night(s) per pit emptying operation depending on the pit's size and the distance to where the sludge is unloaded.
- From 9 p.m. to 4 a.m.
- 1 or 2 times per month, especially in September, October, and December just before the rainy season

Procedure:

- Assessing the amount to be processed and setting the price
- Identifying the materials needed (pails, lever, light, hose for washing)
- Digging the manhole or finding the nearest sewer
- Lifting the upper slab
- Emptying the pit and transporting the sludge to manhole or sewer
- Cleaning the place
- Advising the owner that the work is completed
- Filling the manhole
- Putting back and sealing the slab with cement (additional charge of MGA 6,000)
- Washing the materials at the river. Never at the client's place.
- Obtaining payment. Never asks for down payment.

Perception of the work:

- The hardest part of the job is the lack of sleep because the work has to be done by night.
- It is a manual job that requires physical strength.
- It is a job that requires a lot of courage and determination.

Ideas for improvement:

- Improve materials: find a system to facilitate transportation from the pit to the disposal site.
- Improve equipment: gloves, lever, chisel, sledge hammer, boots, ladder, mask, coveralls

Washing the equipment:

- Washing the equipment at the river. Never at the client's.

Reaction/ text box #2:

- Private management
- Ready to pay 10% to 20% for the obtaining materials and equipment but with some financial assistance

Mahanoro

JEAN NOEL Désiré (called Vazaha). Born on December 25, 1971. 40 years. Separated (2 wives), one child, dependent.

Activities: performs several jobs (plows and harvests fields, makes charcoal, docker, etc.). Has been emptying bucket latrines for 4 years in Mahanoro.

Income: at least MGA 8,000 to 10,000 (out of which MGA 1,500 to 2,000 spent on rum)

- MGA 2,500/day as harvester
- MGA 500 to 1,000 per bag transported
- Fetch wood in the forest and sell it as fuel wood
- Cut wood and make charcoal
- Empties bucket latrines



He performs all tasks and does not refuse any as long as it is an honest job.

He is one of the two men who empty bucket latrines and pits in Mahanoro:

- The principle is simple: they dig a trench near the toilets and empty the contents of the halved barrel or pit there.
- Frequency: almost every day when it does not rain (bucket latrines); otherwise they have to wait for two days after the rain. They empty about one septic tank per month.
- Time required for emptying a bucket latrine: ½ barrel or 100 L of sludge → 1 hour. For a septic tank of average size → 3 hours using a pail
- Rates: ½ barrel → MGA 5000, 1 barrel → MGA 10,000; septic tank → MGA 50,000
- For the manhole: they always dig deeper than the barrel size. If the ground water is too high, they widen the trench. During the rainy season, they do not dig at more than 50 to 70 cm and at most 80 cm and cover with leaves or other plant material before filling with soil. During the dry season, they can dig down to 2 m.

Problems encountered:

- Smell
- Lack of equipment: gloves, mask
- Health problems: none related to emptying pits but shaking due to alcohol
- Social: No major problem with the family and neighbors. The fact that a person that does his job cannot be buried in the family tomb. Children in the streets throw stones at him and call him “the shit collector.” In order not to hear them, he drinks.

A day in Vazaha's life:

- He wakes up at 5.
- He prepares breakfast (cassava, breadfruit, coffee).
- He leaves home at 7h30 if he has no appointment for emptying a pit or a bucket latrine.
- First drink of the day.
- He roams through the town to find a pit or a bucket to empty or any other job.
- If has time, he goes back home to eat. Otherwise, he eats at the market, buying a dish for MGA 400.
- He drinks.

- He roams through the town to find a pit or a bucket to empty or any other job.
- It will be night by the time he goes back home bringing money or rice.

Perception of the job:

- It is not too hard. It is feasible.
- Digging the trench with inappropriate tools makes the job difficult in some cases.

Ideas for improvement:

Improving equipment: gloves, boots, mask

Washing the equipment:

- As regards the bucket latrines, there is nothing to wash except hands.
- For the septic tank, the owner lends the pail. The equipment is washed at the river.

Idea for managing an improved pit/bucket latrine emptying service:

It is a good idea. It would facilitate the job. Owner or manager of the equipment: it does not matter whether it is the commune or a private operator. He will not be able to manage it.

Annex 4

Estimated Amount of Time Needed for Pit Emptying Operation

1. Options for Ambositra



2. Option for Mahanoro (12 m³)

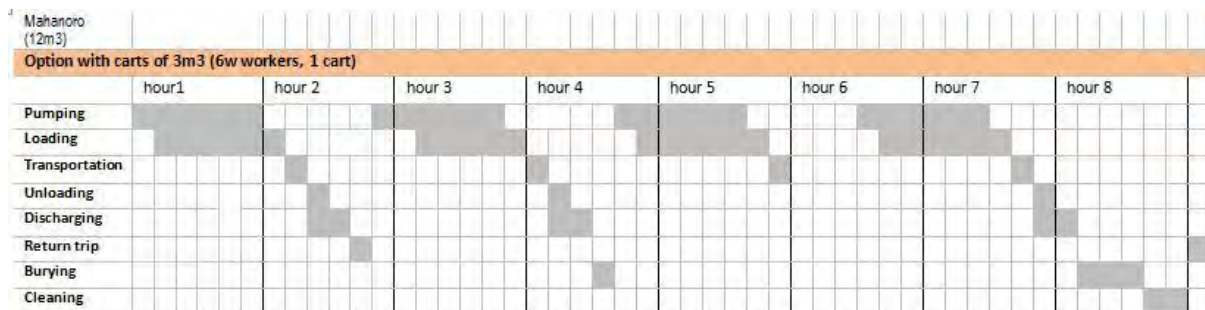

Annex 5
Drawings

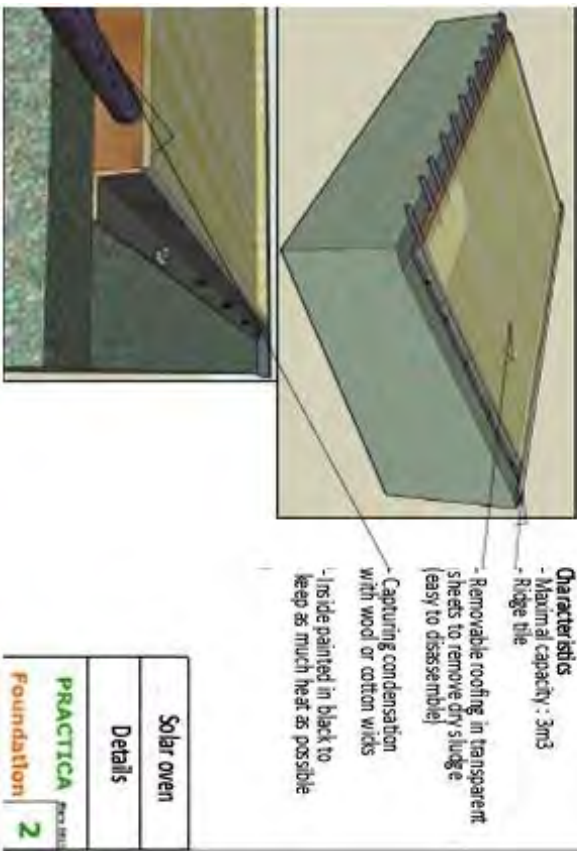
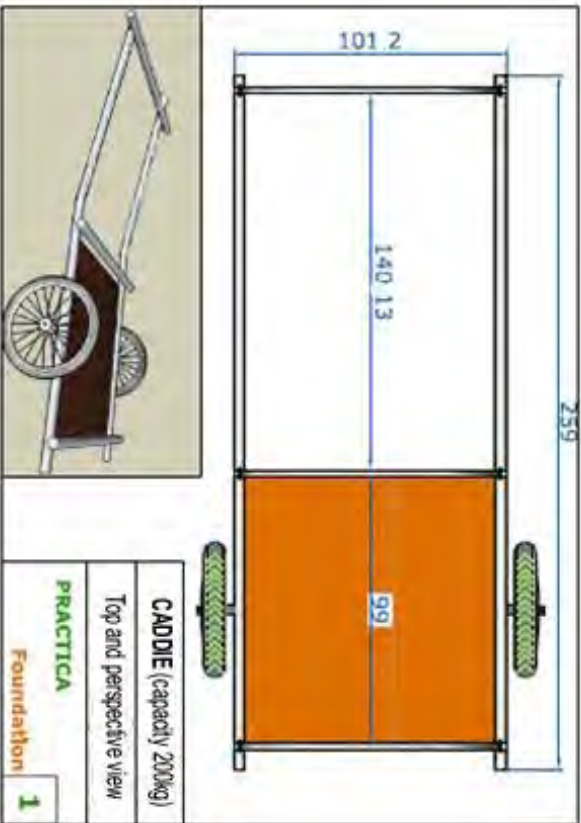
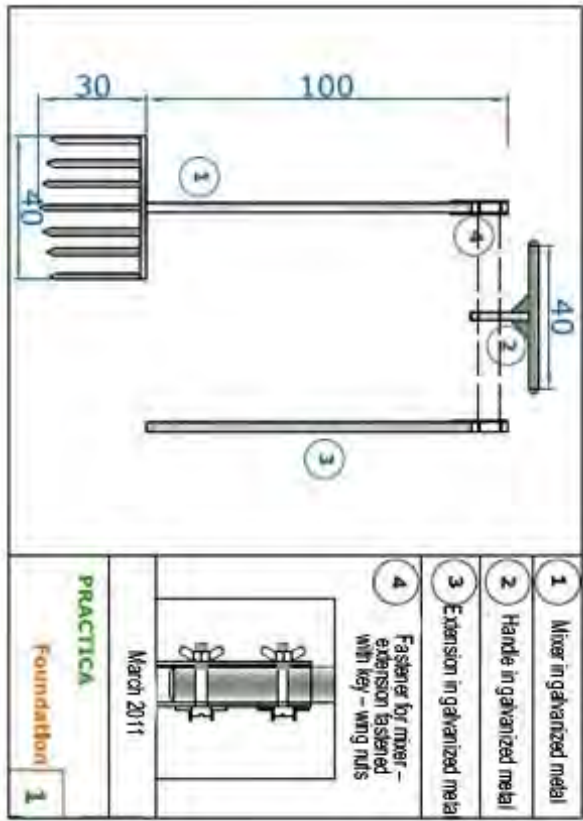
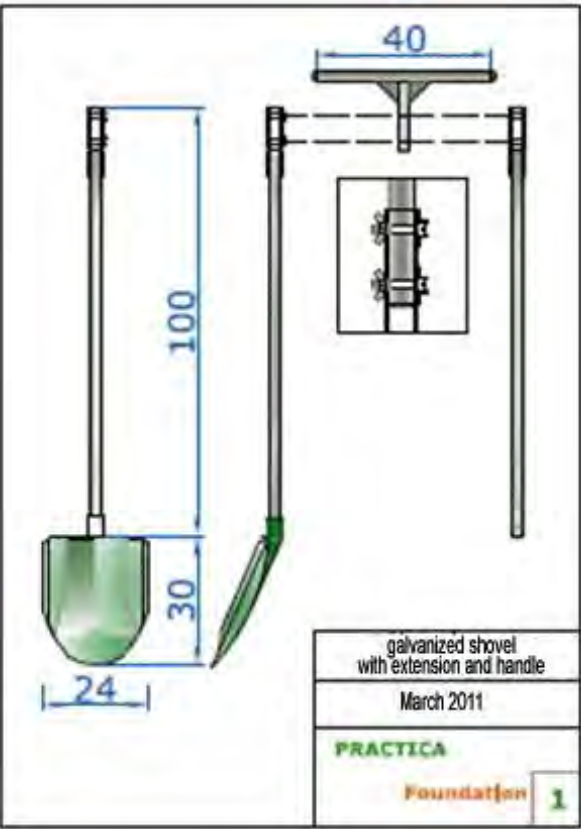

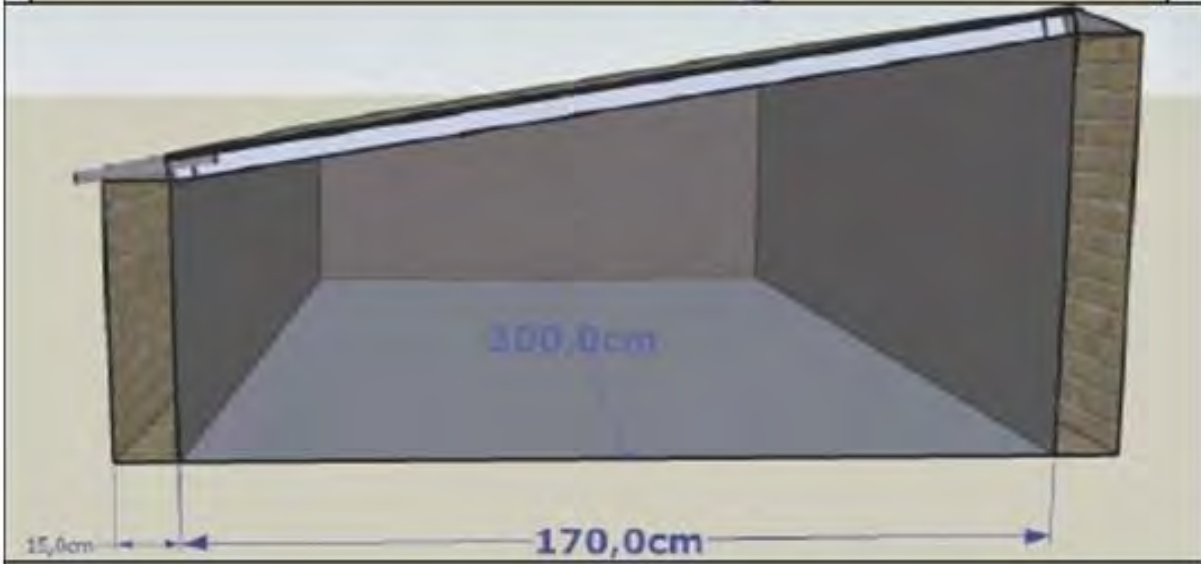
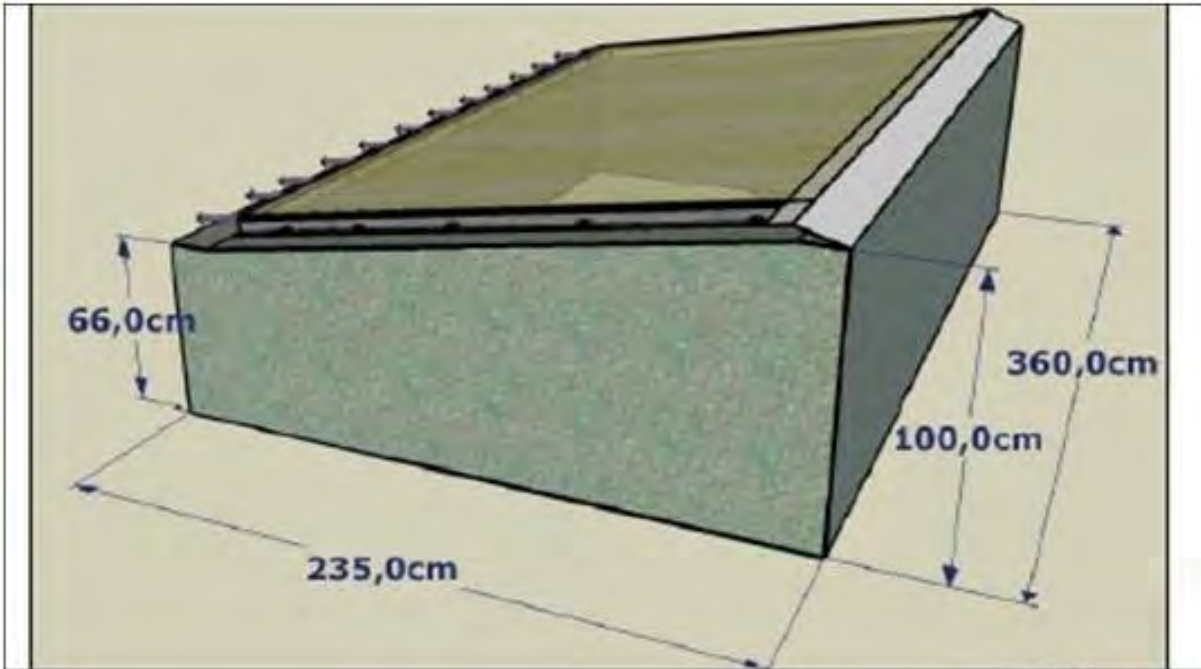

Solar oven 3m ³	
Overview	
PRACTICA	March 2011
Foundation	1

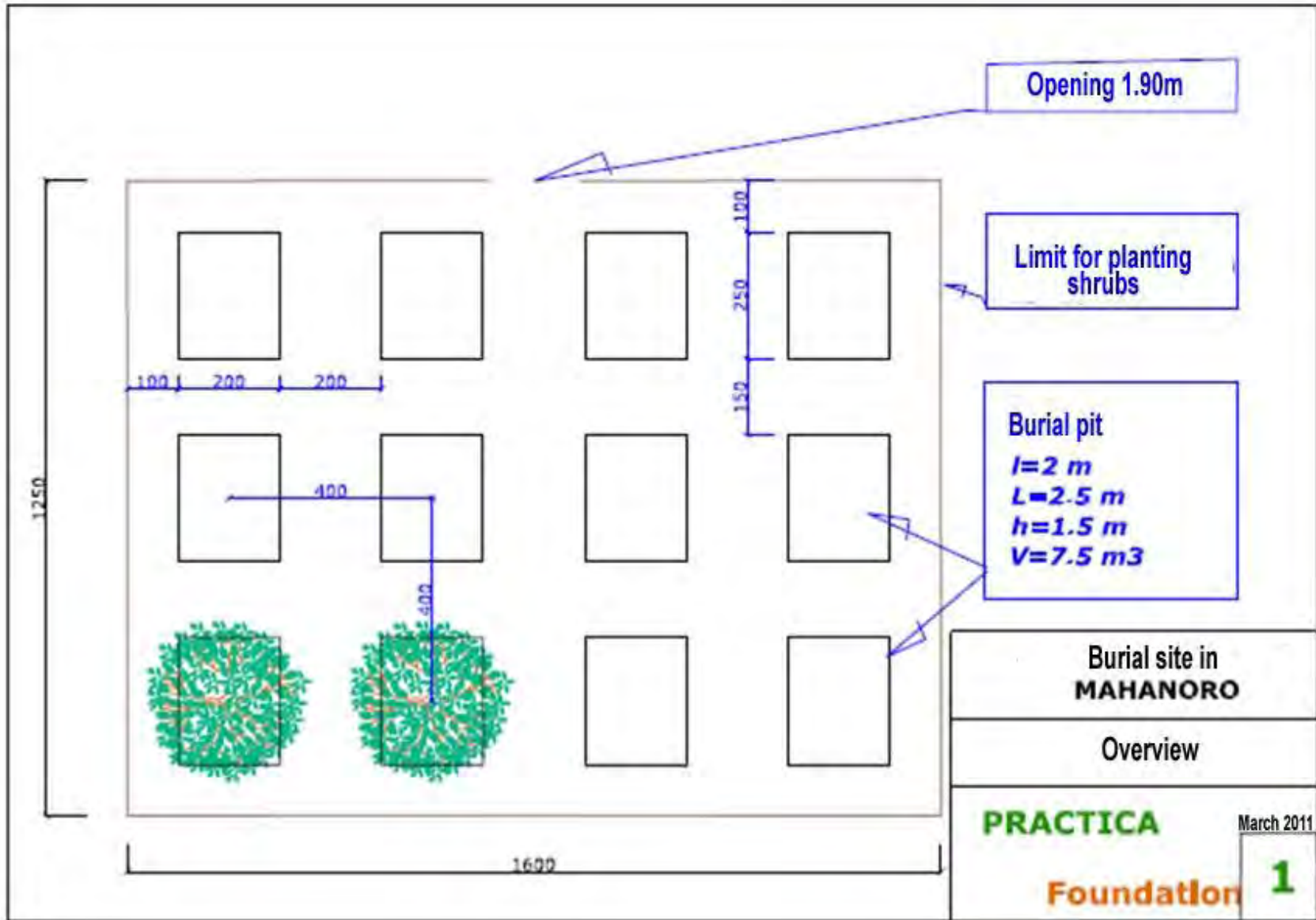

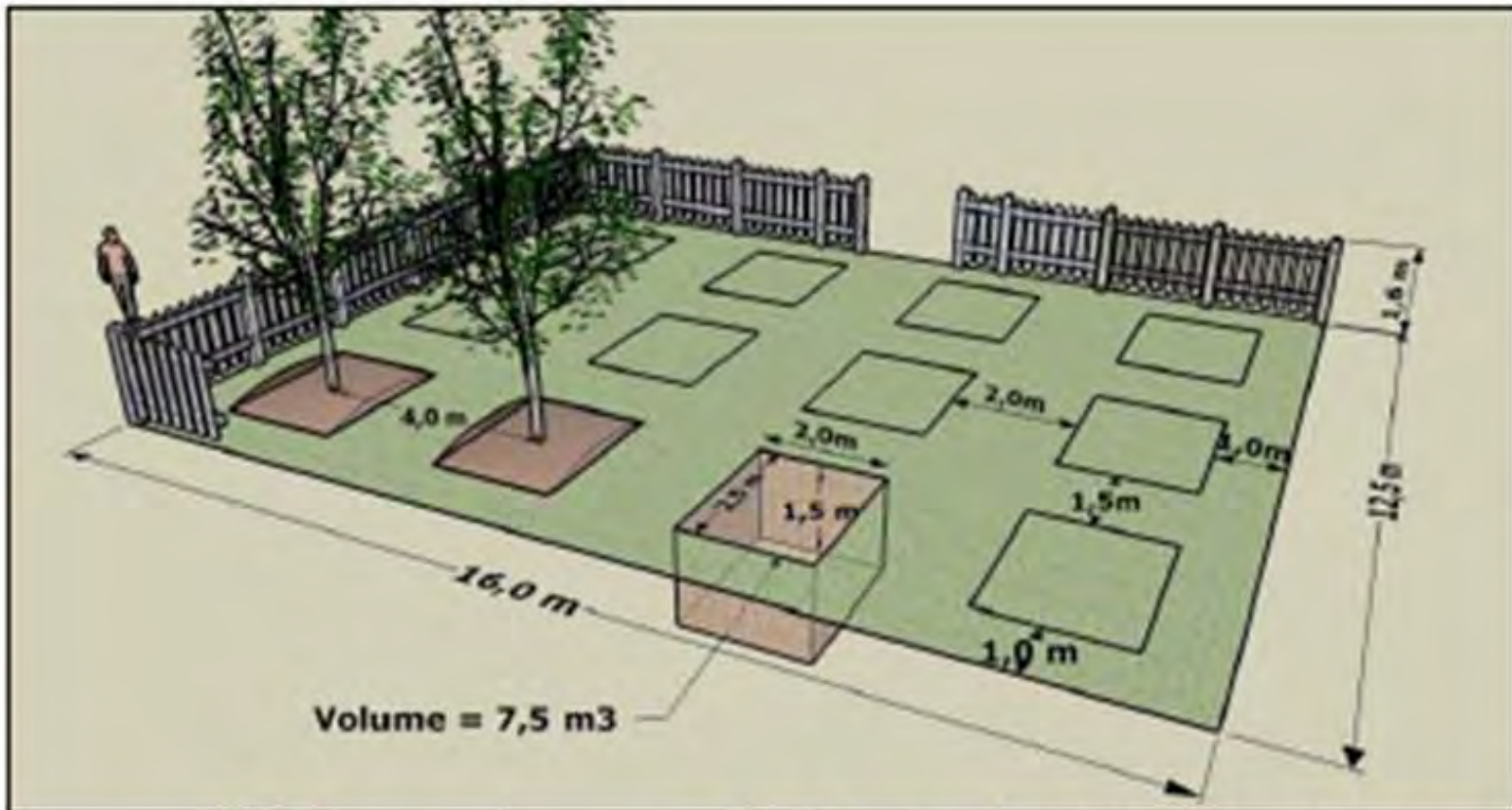

Volume = 7,5 m³



Burial site in Ambositra
Perspective view

PRACTICA

March 2011

Foundation

3

WASHplus
U.S. Agency for International Development
Bureau for Global Health
Office of Health, Infectious Diseases and Nutrition
1300 Pennsylvania Ave.
Washington, DC 20523

www.usaid.gov

www.washplus.org