

Guidelines for the Safe Carriage and Delivery of Drinking-water

Ministry of Health. 2008. *Guidelines for the Safe Carriage and Delivery of Drinking-water*. Wellington: Ministry of Health.

Published in June 2008 by the
Ministry of Health
PO Box 5013, Wellington, New Zealand

ISBN 978-0-478-31728-2 (print)
ISBN 978-0-478-31729-9 (online)
HP 4576

This document is available on the Ministry of Health's website:
<http://www.moh.govt.nz>



MANATŪ HAUORA

Contents

1	Tankered Drinking-water Carriers: Guidelines	1
1.1	Background	1
1.2	DWSNZ 2005 section 11: Tankered drinking-water compliance criteria	1
2	Scope and Administration of the Guidelines	3
3	Source and Class of Water	4
4	Registration of Carriers	5
4.1	The role of the drinking-water assessor	5
4.2	Registration process	5
4.3	Gaining tank approval	6
5	Operating Requirements	7
5.1	Operator	7
5.2	Vehicle	7
5.3	Tanks	7
5.4	Ancillary equipment	8
5.5	Loading water	8
5.6	Discharging water and customer care	9
5.7	Tank storage during winter	9
5.8	Civil emergency	10
6	Water Quality Monitoring	11
6.1	<i>E. coli</i> sampling	11
6.2	Analytical results	11
7	Documentation	12
7.1	Delivery dockets	12
7.2	Office records	13
7.3	Public health risk management plans	13
Appendices		
	Appendix 1: Glossary of Terms and Definitions	14
	Appendix 2: Forms	16
	Appendix 3: Cleaning Procedure Example	41
	Appendix 4: Tanker Disinfection and Residual Chlorine Tests	42
	Appendix 5: Delivery Docket Example	46
	Appendix 6: Tankered Drinking-water Carriers: Reference Guide to the Health (Drinking-Water) Amendment Act 2007	47
	Appendix 7: Customer Notification Example	59
	Appendix 8: Key Contacts (DWAs)	60
	Appendix 9: Example Public Health Risk Management Plan	63

List of Tables

Table 1:	Disinfection dosing rates using sodium hypochlorite (NaOCl) solution	43
----------	--	----

List of Figures

Figure 1:	Backflow prevention using air gap	9
Figure 2:	Sampling tap	11
Figure 3:	Example of chlorine test kit using a comparator and colour disc	44

1 Tankered Drinking-water Carriers: Guidelines

1.1 Background

Safe drinking-water that is free from contamination is vital to the wellbeing of everyone. Contamination could be chemical, radiological or microbiological but, generally, it is only microbiological contamination through bacteria, viruses or protozoa that will lead to rapid and widespread illness and that may sometimes be fatal. For this reason, protozoa and the bacterium *E. coli* are classified as Priority 1 determinands by the Ministry of Health. In other words, microbiology is the area that the Ministry of Health is most concerned about.

Over the years, the Ministry has developed and implemented a series of standards and guidelines designed to minimise the risk of supplying contaminated drinking-water.

The Ministry contracts the District Health Boards (DHBs) to employ drinking-water assessors (DWAs) who monitor compliance of drinking-water supplies. The Drinking-water Standards for New Zealand (DWSNZ 2005) provide standards for tankered water, and came into effect on 1 January 2006, superseding earlier standards. The DWSNZ 2005 sets minimum standards, but also encourages identification, management and minimisation of risks through adoption of a public health risk management plan (PHRMP). Tankered drinking-water carriers (TDWCs) are addressed in section 11 of DWSNZ 2005 because they are part of the water supply chain. Carriers of drinking-water in New Zealand must ensure that any water sold or supplied for potable purposes, that is, drinking and food preparation or personal hygiene, meets the requirements of section 11 and that the water is protected from contamination at all times during its loading, transit and delivery.

The Health (Drinking Water) Amendment Act 2007 (The Act) regulates that all practical steps must be taken to comply with the DWSNZ 2005. The Act contains specific compliance provisions and penalties for non-compliance with the legislation. Under section 69ZZQ of the Act, it is an offence if the water carrier transports more than five loads of raw water or drinking-water for more than five days in any 12-month period unless that carrier is registered or authorised to supply water by a medical officer of health.

The DWSNZ 2005 will be refined and superseded over time. Therefore, it is important to be aware of the latest standard, and its relevance and application to these guidelines.

1.2 DWSNZ 2005 section 11: Tankered drinking-water compliance criteria

A key point in section 11.1 of the DWSNZ 2005 is that TDWCs who provide drinking-water to customers must be on the Register of Community Drinking-water Supplies and Suppliers in New Zealand.

Section 11 also covers the procedures to be observed for transport of drinking-water by tanker, monitoring of the quality of the water for contamination, delivery information, documentation and record-keeping requirements.

These guidelines have been developed after consultation with TDWCs, the Ministry of Health and other interested parties to assist carriers to meet their legal requirements.

Adoption of the guidelines will not only meet the Ministry of Health's requirements for the drinking-water tanker industry, but will also minimise customer concerns regarding transportation of drinking-water.

2 Scope and Administration of the Guidelines

The scope of these guidelines is to provide a best practice framework to be used by all TDWCs in New Zealand. This will ensure that water of appropriate quality is tankered and maintained in the same condition during transit and delivery to the customer.

Appendix 1 defines terms used in these guidelines.

Where a tanker operator provides water taken from their own source, for example, a bore, they must also comply with the requirements of section 10 of the DWSNZ 2005: Small water supply compliance criteria. These source requirements are outside the scope of these guidelines. The guidelines that cover small water supplies are detailed in the *Guidelines for the Management of Drinking-water Quality in New Zealand*, issued by the Ministry of Health.

Tankered drinking-water is defined here as water delivered by tanker and not through a water reticulation system. It is preferably sourced from a registered drinking-water supply that complies with the current DWSNZ. It also covers road or rail water deliveries to the customer's storage facility on a commercial or voluntary basis.

In most cases, a water supplier will be a local government organisation, such as a territorial authority (TA), council controlled organisation (CCO), local council or a local authority trading enterprise (LATE), with the water taken from a reticulated supply. This is likely to be Class 1(a) water but may be Class 1(b) or Class 2; see section 11.2 of the DWSNZ 2005.

3 Source and Class of Water

The customer must be advised by written statement (for example, on the delivery docket, see section 7.1) of the source and class of water being delivered. Water delivered by tanker is categorised into two main classes. These classes represent the expected risk or quality of water being delivered to the customer.

- Class 1(a) water is water taken from a reticulated water supply that complies with the DWSNZ 2005 and is listed in the Register of Community Drinking-water Supplies and Suppliers in New Zealand. For example: reticulated council supply.
- Class 1(b) water is water that has been taken from an independent water source that has been approved by a DWA as complying with DWSNZ. For example: own bore with appropriate treatment.
- Class 2 water is water intended for drinking purposes and although it does not fit into the above two categories, has been approved by the DWA. An example is: river water with partial treatment (for example, chlorination).

The delivery statement must also contain information from the DWA, who may require the statement to include the source and class of water, and if necessary, a 'boil water' notice.

A water carrier should always use the highest standard of water available.

4 Registration of Carriers

4.1 The role of the drinking-water assessor

The DWA is the main point of contact for the TDWC. The DWA should be contacted to arrange your application for registration. Contact details for DWAs can be obtained from the local public health service of the DHB (see Appendix 8). TDWCs may operate across health board boundaries, but only one DWA contact is necessary. The TDWC should nominate which health district they wish to be registered in.

4.2 Registration process

Fill out a registration form (see Appendix 2) and send it to the DWA in your region. The key information required is the:

1. name of the legal business owner
2. company and trading name, address and contact details
3. name of the primary contact
4. DHB that the business is registered in
5. water suppliers or sources that will be used
6. 'prescribed' particulars relating to each vehicle (and associated equipment) used to transport water.

Permission to abstract water from the nominated sources should first be obtained from the owners of those supplies.

The DWA may wish to discuss details of the registration and may require tanks to be inspected by an independent qualified person (IQP) to determine whether they are fit for purpose.

Registration must be renewed annually. There is no charge for registration. Inform the DWA if there are any changes to your business during the 12 months for which you are registered.

The Ministry of Health will arrange the issue of a registration certificate to confirm your listing on the Register of Community Drinking-water Supplies and Suppliers.

Where a water carrier is also a member of the Tankered Drinking Water Carriers Association Incorporated (TDWCAI), that entity may also issue a certificate of membership to its members. This is independent from any Ministry of Health requirements.

4.3 Gaining tank approval

4.3.1 Networked (reticulated) supply source water

Most, but not all, reticulated water supplies should be Class 1(a).

Once TDWCs are registered on the Ministry of Health's Register of Community Drinking-water Supplies and Suppliers, they should approach the council or private water supplier to:

- seek approval for the delivery tanks
- obtain any local licence and conditions
- arrange a supply contract
- obtain details of all approved water filling points that the tanker operator is approved to use.

Some councils may issue tank certificates or stickers that may refer to a supply contract, registration or licence issued by the council, and whether the tanks are fit to take water from the water supply (for example, whether they have a suitable backflow prevention system). The council may require the backflow preventer to be tested by a council approved IQP at least once a year. This would be specific to the council concerned and separate from any Ministry of Health requirements.

Where the water filling points are metered, a TDWC may receive a monthly invoice, depending on the council.

4.3.2 Non-networked (non-reticulated) supply source water

This section refers to Class 1(b) or Class 2 water.

Water taken from a Class 1(b) or Class 2 water source will require the approval of a DWA prior to initial use. In addition, the DWA will require to see a 'water take' permission from the water supplier or regional council, which will include any conditions of take.

Contact the DWA in your region for details.

5 Operating Requirements

5.1 Operator

All tanker operators or drivers who collect and deliver water should hold a copy of these guidelines.

Drivers of all tankers used for transportation of drinking-water must carry an appropriate form of identification. This should be available on request.

Drinking-water is a food, so personal hygiene is important to prevent spread of germs. Therefore:

- do not work with water if you are feeling unwell or have a stomach upset
- wash hands regularly; carrying a bucket and soap or some liquid waterless cleanser is recommended
- cover open wounds.

5.2 Vehicle

Vehicles being used for transportation of drinking-water must:

- be maintained at all times to a standard befitting the drinking-water industry
- be marked clearly with the company name and nature of business; and
- comply with any local regulations and national standards set by Land Transport New Zealand.

5.3 Tanks

Tanks should be marked clearly as carrying drinking-water. Each tank should display any certification issued for that tank.

Operators of any vehicles used to transport drinking-water must ensure that all tanks and systems used for loading or unloading water have not been used previously for transporting any noxious, toxic or hazardous matter, non-food liquids or human or animal wastes, unless a DWA has certified them to be clean.

Operators must also ensure that the tank and contents are protected from contamination during loading, transportation and delivery.

5.3.1 Tank cleaning and maintenance

Cleaning and disinfection of the tank must be carried out before drinking-water is tankered and after any cargo other than drinking-water has been carried, such as non-potable water, milk, fruit juice or beer. The cleaning and disinfection process must be approved by a DWA before being used to transport drinking-water.

An example of a 'cleaning procedure' is provided in Appendix 3.

Stainless steel tanks are recommended for transportation of water because they are easiest to keep clean and less likely to rust or impair the taste of the water.

The water supplier or regional council may advise where the tank can be cleaned and where the cleaning water can be discharged. It may be a requirement of the TA to have a trade waste consent to discharge cleaning water within a TA system and that permission for making any discharge of cleaning waste should be obtained. This requirement may change to reflect local laws and regulations.

5.4 Ancillary equipment

Ancillary equipment, including hoses and couplings, must be stored in a separate well-ventilated storage locker in a secure and sanitary manner when not in use. Ensure hoses are as clean and dry as possible before storing for an extended time to prevent mould growth.

It is also recommended that:

- lie-flat hoses are used because water is excluded (and contamination potential is reduced) as the hoses are rolled
- rigid pipes and external pumps are plugged or capped during transit to prevent ingress of dirt
- mud is washed off the outside of hoses
- hoses are disinfected if not in use for more than 30 days
- footwear and wet weather gear is stored separately from hoses and pipes.

5.5 Loading water

When water is taken from a reticulated supply, the water supplier's requirements in respect of backflow prevention, metering, filling points and use of the water supplier's equipment must be complied with at all times.

The water supplier's approval is required to take water from filling facilities or filling points, for each supply being used. Failure to obtain such approval may be an offence under section 69ZZR 4(d) of the Health (Drinking Water) Amendment Act.

The approval should be in the form of a written agreement or supply contract to ensure that the water is not taken illegally. Carriers will nominate preferred filling points and will be authorised only for those points. Any changes must be authorised by the water supplier and approved by the DWA. Where it is intended to fill a tank from a mains supply that has no backflow prevention, a permanently mounted air gap of twice the nominal delivery pipe diameter, but no less than 25 mm, must be installed between the pipe outlet and the tank being filled, see Figure 1. Consult the water suppliers for appropriate backflow prevention.

Figure 1: Backflow prevention using air gap

Minimum 25 mm air gap

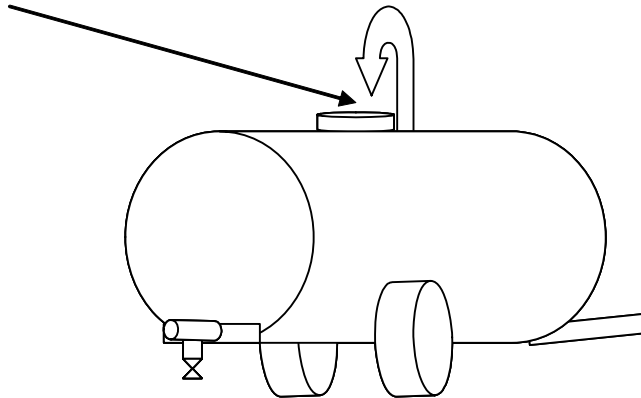

5.6 Discharging water and customer care

Take care to prevent contamination of the water while discharging into the customer's tank.

It is recognised that it is difficult to prevent re-suspending settled sludge when filling customers' water tanks. To reduce the length of time required for the water to settle after filling, it is useful to baffle the direct stream from the delivery hose or to aim the water to discharge along the side of the tank rather than directly into the tank. Reducing the flow into the tank will also reduce the amount of re-suspension, but this may not always be practical.

The time required for the water to settle and clear can be several hours. Therefore, it is recommended that a storage container (approximately 5 litres) of delivered water is left with the customer. This provides them with safe drinking-water while the water in the tank is clearing, and offers reassurance about the quality of the water delivered. Arrange for a container to be ready when delivering the water. If customers are not home when the water is delivered, store the container away from direct sunlight.

If delivering to a new customer or a customer who does not appear to be managing their drinking-water tank correctly, the water carrier should leave a Ministry of Health leaflet entitled 'Water Collection Tanks and Safe Household Water' Publication Code 10148, along with the delivery docket. Leaflets are available from the DWA free of charge and can also be ordered from the Ministry's website. In addition, an example of a 'Customer Notification' has been provided in Appendix 7.

5.7 Tank storage during winter

If the delivery tank is not intended to be used during winter or for any single period of more than 30 days:

- drain the tank and close all valves
- wash and clean hoses, cap the ends and store in a clean locker
- empty the pump and plug the ends.

Before delivering drinking-water again, clean and disinfect the tank according to the cleaning schedule (see Appendices 3 and 4). Arrange for an *E. coli* test with a Ministry of Health-recognised laboratory. A register of laboratories recognised by the Ministry for the purpose of testing drinking-water is published on the Ministry's website. For further information on laboratories contact the DWA or local council.

5.8 Civil emergency

Special dispensation exists for civil emergencies where drinking-water is required for such events. Consult the DWA for further information.

6 Water Quality Monitoring

6.1 *E. coli* sampling

Samples of water from the delivery tank must be collected for *E. coli* testing by a Ministry of Health-recognised laboratory, or another person that has been assessed as competent to carry out such field tests. This assessment of competency can be conducted by the local DWA. *E. coli* sampling needs to be conducted as per the following schedule:

- every third month, if the water being carried is Class 1(a) and contains at least 0.2 milligrams per litre (mg/L) free available chlorine (FAC) or equivalent at the filling point
- monthly, if the water being carried is Class 1(a) but is not chlorinated
- as specified by the DWA, if the water carried is from any other source, that is, Class 1(b) or Class 2.

Most reticulated water supplies will have residual chlorine content, but check with the council or supplier if in doubt.

Arrange sampling of the tank for *E. coli* with the DWA. This may incur a cost, although in some cases the local council may help with this expense. All water samples must be collected during the unloading or discharge process. A sampling tap on the outlet valve or pipe-work provides a convenient point for the sample collection, see Figure 2.

Figure 2: Sampling tap

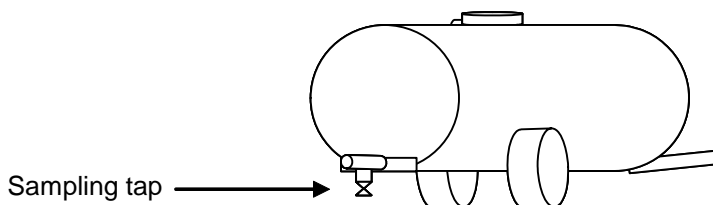

6.2 Analytical results

E. coli tests must be carried out by a Ministry of Health-recognised laboratory unless the Director general has approved in writing alternate procedures that may be used to analyse or test the raw water or drinking water (section 69ZZ (1)(b)). The results are sent to a centralised database managed by ESR on behalf of the Ministry of Health. Test results are forwarded to the person who requested them; this would usually be either the water carrier or the DWA. If the DWA requests the test then, normally, the carriers would not see the results, but they would be made available on request.

If a positive *E. coli* test is found and reported to the TDWC, it is the responsibility of the carrier to report this immediately to the DWA, who may require that no further water is to be transported from that source or in that tank until the reason for the positive test has been identified and dealt with to the satisfaction of the DWA. The DWA may also issue a 'boil water' notice.

7 Documentation

Keeping accounts and dockets will ensure traceability, should any contamination occur. It is important that the documentation is kept up to date. The DWA may wish to inspect this information at short notice, particularly if there is a problem with the supply. Falsifying or failing to keep records is an offence under sections 69ZZR 2(a) and 69ZZT of the Health (Drinking Water) Amendment Act.

The DWSNZ 2005 requires records to be kept for a minimum of 10 years. This is in order to provide historical trends of parameters, which may be prove to have health implications in the future. The records will allow the Ministry to look back over the years and to see how a particular parameter has affected a community's health. The 10-year retention period is a legal requirement under the Health (Retention of Health Information) Regulations 1996.

The information that must be kept is:

- date of delivery
- delivery address
- load transported (class and source)
- tanker cleaning schedule.

This information can be stored in electronic format, that is, taken from account records and stored on CD. However, be aware of changes in storage format; for example, do not store records on floppy disks because the data may be lost. Keep back up copies in case a disk is lost or is not readable in 10 years' time.

7.1 Delivery dockets

The customer must be informed of the source from which the water was taken, the class of water delivered and, where applicable, the grading of the treatment plant and distribution system (including the meaning of the grading). This can be a simple statement on the delivery docket. If the source and class is always the same this can be preprinted on the dockets. Grading information is available from the DWA.

If the water is supplied to non-residential premises, the statement must be displayed in a prominent location that allows all potential customers or users to read it. If the water is Class 2, the statement must also contain information from the DWA, who may require the statement to include a 'boil water' notice.

An example of an acceptable delivery docket containing a key message from the Ministry of Health is attached (Appendix 5). The notice from the DWA regarding Class 2 water will be in addition to this key message.

7.2 Office records

Office records of the tanker operation must include not only dates and details of deliveries and customer records, but also dates and details of deliveries of non-potable liquids, tank cleaning operations including quantities of disinfectant used and the sampling programme. Records also need to be maintained on when the tanker has been out of service.

7.3 Public health risk management plans

A public health risk management plan (PHRMP) is a proactive plan that seeks to protect the customer by identifying potential risks and putting programmes in place to mitigate such risks.

For example, there is a risk of backflow from a loaded tanker contaminating a public water supply. Backflow prevention mitigates this risk.

It is a requirement of the Health (Drinking Water) Amendment Act 2007 that water suppliers complete a PHRMP. This plan is required to be reviewed and revised on a regular basis. TDWCs are also required to complete a PHRMP in relation to their method of transporting water intended for drinking.

Contact the DWA for PHRMP information sources. An example of a simple PHRMP is attached as Appendix 8.

Appendix 1: Glossary of Terms and Definitions

Approved source is a source of drinking-water approved by a DWA.

Backflow is a flow that is contrary to the normal intended direction of flow. In this case, it would normally relate to flow from the tanker back into the water supplier's system.

Backflow prevention device is a device to prevent backflow and includes reduced pressure backflow devices, double check valves (testable and non-testable), dual check valves, vacuum breakers and air gap separation.

Boil water notice is a notice to customers of a water supplier or carrier that the water being supplied may be contaminated with pathogenic (harmful) organisms and should be boiled before using for drinking, food preparation, and brushing teeth.

Contaminant is any substance or organism in water that can cause undesirable health or aesthetic effects.

CCO means council controlled organisation.

Customer means an owner or occupier of premises or property to which the tankered drinking-water is supplied.

Determinand is constituent or property of water that is determined, or estimated, in a sample. An example of a microbiological determinand is total coliforms. A chemical determinand might be chloride. Examples of a physical determinand are turbidity and colour. One radiological determinand is radon.

DHB means District Health Board.

Disinfection residue is the amount of disinfectant that is present in drinking-water at any time.

Drinking-water is water used for human consumption, food preparation, utensil washing, oral and personal hygiene.

Drinking-water assessors (DWA) are assessors appointed under the Health (Drinking Water) Amendment Act.

Drinking-water Standards means the current and valid set of Drinking-water Standards for New Zealand to assess the quality of drinking-water.

DWSNZ 2005 means Drinking-water Standards New Zealand 2005.

***E. coli* (*Escherichia coli*)** is a bacterium used as an indicator that faecal contamination has almost certainly occurred and, therefore, there is a risk that pathogens (disease-causing organisms) are present.

ESR is the Institute of Environmental Science and Research Limited, a Crown research institute with major sites in Auckland, Wellington and Christchurch.

Filling point is the point at which ownership changes from the supplier, in this case, to the tanker operator's tanker.

Free available chlorine (FAC) is the concentration of chlorine present in water as hypochlorous acid or hypochlorite ion.

Guideline means a preferred course of action, process or procedure.

HTH is high test hypochlorite, a form of calcium hypochlorite.

IANZ means International Accreditation New Zealand.

Indicator organism means a determinand, for example, *E. coli* or faecal coliform, which is monitored to indicate the presence of faecal contamination.

IQP means an Independent Qualified Person who is accepted by the territorial authority as being appropriately qualified to undertake inspection and maintenance of the attribute concerned. This person must not have a financial interest in the outcome.

LATE means local authority trading enterprise.

Maximum acceptable value (MAV) means the concentration of a determinand below which the presence of the determinand does not result in any significant risk to the customer over a lifetime of consumption.

Networked supplier (reticulated) means a drinking-water supplier who supplies drinking-water from the place where the supply is to one or more other properties, by means of a pipe connecting those properties.

PHRMP means public health management plan.

Potable water means drinking-water that does not contain or exhibit any determinand to an extent that exceeds its maximum acceptable value (MAV) more frequently than allowed when water quality is measured as specified in the DWSNZ 2005.

Register of Community Drinking-Water Supplies and Suppliers in New Zealand is a list of drinking-water supplies and suppliers in New Zealand, published by the Ministry of Health. It contains each drinking-water supply's details about water sources, treatment plants, distribution zones, site identification codes, Priority 2 determinands and public health grading.

Reticulation means a network of pipes, pumps and service reservoirs that delivers drinking-water from the water treatment plant to the customer's boundary.

TA means territorial authority.

Tankered drinking-water is any water collected from an external source and delivered in a tank to a customer's drinking-water storage system.

Tankered drinking-water carrier (TDWC) means any individual drinking-water carrier or company registered with the Ministry of Health as a recognised carrier of drinking-water as defined under drinking-water above.

Tankered Drinking Water Carriers Association Incorporated (TDWCAI) is a recently established body that advocates on behalf of its tankered water carrier members.

Water take permission means permission from a supplier for a TDWC to take water from a source or supply

Wholesome water means potable water that does not contain any determinands that exceed the guideline values for aesthetic determinands in the DWSNZ 2005.

WINZ means Water Information New Zealand (WINZ), a database maintained by ESR on behalf of the Ministry of Health.

Appendix 2: Forms

- Form WC01: Application for Water Carrier Registration
- Form WC02: Advice of change of details
- Form WC03: Application for Water Carrier Registration Renewal
- Form WC04: Application to Medical Officer of Health to Operate as a Temporary Water Carrier (emergency management provisions will apply)
- Form WC07: Delivery docket
- Form WS01: Application for Water Supply Registration
- Form WS02 Application for Removal from Drinking-water Register
- Form WS03: Application to Medical Officer of Health to use Temporary Drinking-water Supply
- Form WS04: Application for authorisation of person(s) to perform drinking water analyses

Application for Water Carrier Registration

Health (Drinking Water) Amendment Act 2007, Section 69N

The Drinking Water Assessor (DWA) in your district can assist you with filling out this form.

Water carrier trading as:					
Water carrier owner: (may be a company/ organisation name)					
Name of person responsible: (must be a named individual)					
Position:					
Address:					
Phone:		Fax:		Email:	
Date form completed:	/	/	Office use only		
			Date registration entered:	/	/

Instructions

If you require help in completing this form, please contact the drinking water assessor at your local District Health Board.

- Fill in Part A of this form if you are obtaining water from a registered water supply owned by someone else.
- Fill in Part B of this form if you are using your own water supply.
- All water carriers to fill in Part C of this form.

Part A

If you are obtaining water from a registered water supply owned by someone else, fill in the table below.

- Up to three different water supplies can be entered, if you are using more than three please complete another form.
- The applicable names and registration codes can be found in the Drinking-water Register.
- If you are unsure what distribution zone you are filling from, contact the drinking-water supplier to confirm.
- If the drinking-water supply you are using is not registered, but is owned by someone else, a separate water supply registration form must be completed.

Water supply 1 Community name:	Source name:		Source code:	
	Treatment plant name:		Treatment plant code:	
	Distribution zone name:		Distribution zone code:	
Water supply 2 Community name:	Source name:		Source code:	
	Treatment plant name:		Treatment plant code:	
	Distribution zone name:		Distribution zone code:	
Water supply 3 Community name:	Source name:		Source code:	
	Treatment plant name:		Treatment plant code:	
	Distribution zone name:		Distribution zone code:	
Water supply 4 Community name:	Source name:		Source code:	
	Treatment plant name:		Treatment plant code:	
	Distribution zone name:		Distribution zone code:	

Part B

If you are using water from your own water supply, fill in the treatment plant and source tables below.

- Do not fill in the TPCode and SCode (this will be entered when registration is finalised).
- The source name should identify whether the source is a groundwater supply or a surface water supply (eg, Smiths Road Bore or Ashley River).
- The GPS should be in the NZTM seven digit grid reference system (eg, 2125670E, 5710600N).
- Up to three different treatment plants and sources can be entered on this form.
- Some treatment plants may have more than one source of water, enter the associated source waters underneath the treatment plant.

Treatment plant(s)					
TPCODE:		TPCODE:		TPCODE:	
Name:		Name:		Name:	
GPS:		GPS:		GPS:	
Location description:		Location description:		Location description:	

Source(s)					
SCODE:		SCODE:		SCODE:	
Name:		Name:		Name:	
GPS:		GPS:		GPS:	
Location description:		Location description:		Location description:	

SCODE:		SCODE:		SCODE:	
Name:		Name:		Name:	
GPS:		GPS:		GPS:	
Location description:		Location description:		Location description:	

Part C

All water carriers must fill in the tables below.

Vehicle / Vessel / Rail Wagon / Tanks (Enter separately all vehicles, trailers, demountable tanks. If registration number is not applicable, generate a permanent identification number that can be checked on the equipment)			
Description		Identification / registration #	
Description		Identification / registration #	
Description		Identification / registration #	
Description		Identification / registration #	
Description		Identification / registration #	
Description		Identification / registration #	
Description		Identification / registration #	
Description		Identification / registration #	

Hoses and Fittings						
Notes:						
1. Identify the type of hoses and fittings used, eg, solid moulded hose, lay-flat hose. Enter each type of hose or fitting on a new line.						
2. Circle either 'yes' or 'no' to state whether the type of hose or fitting is suitable for the purpose of delivering potable water.						
Type of hose or fitting used		Suitable for delivering potable water?	Yes		No	
Type of hose or fitting used		Suitable for delivering potable water?	Yes		No	
Type of hose or fitting used		Suitable for delivering potable water?	Yes		No	
Type of hose or fitting used		Suitable for delivering potable water?	Yes		No	
Type of hose or fitting used		Suitable for delivering potable water?	Yes		No	

Signed _____ (person responsible for water carrier)
 Name of DWA _____ Signed _____ DHB _____

Office use only	
Summary of action taken by DWA:	
Date form submitted to ESR:	/ /
Identification code #	

Change of Details to Water Carrier Registration

Health (Drinking Water) Amendment Act 2007, Section 69M

Form to be used only if you have made changes to your water supply source, tanker, hoses, fittings or other equipment since your last registration.

Water carrier trading as:					
Water carrier owner: (may be a company/ organisation name)					
Name of person responsible: (must be a named individual)					
Water carrier registration code: (from drinking-water register)					
Date form completed:	/	/	Office use only		
Date modification applies from:	/	/	Date registration amended:		/

1. Give details below of the change that needs to be made to the water carrier registration (if you are filling from a different registered drinking water supply, see question 2 below).

2. If you are filling from a different registered drinking-water supply, enter detail in the table below.

- The applicable names and registration codes can be found in the Drinking-water Register.
- If you are unsure what distribution zone you are filling from, contact the drinking-water supplier to confirm.

Water supply 1 Community name:		Source name:		Source code:	
		Treatment plant name:		Treatment plant code:	
		Distribution zone name:		Distribution zone code:	
Water supply 2 Community name:		Source name:		Source code:	
		Treatment plant name:		Treatment plant code:	
		Distribution zone name:		Distribution zone code:	

Signed _____ (person responsible for water carrier)

Office use only	
Summary of action taken by DWA:	
Date form submitted to ESR:	/ /

If you require help in completing this form, please contact the drinking water assessor at your local District Health Board.

Water Carrier Registration Renewal

Health (Drinking Water) Amendment Act 2007, Section 69L

The Drinking Water Assessor (DWA) in your district can assist you with filling out this form.

Water carrier trading as:					
Water carrier owner: (may be a company name)					
Name of person responsible: (must be a named individual)					
Position:					
Address:					
Phone:		Fax:		Email:	
Date form completed:	/	/	Office use only		
			Date registration entered:	/	/

- Please enter details of all vehicles, vessels, rail wagons and associated equipment (such as demountable tanks, hoses and fittings) used in association with the carriage of water in the tables below.**

Vehicle / Vessel / Rail Wagon / Tanks (Enter separately all vehicles, trailers, demountable tanks. If registration number is not applicable, generate a permanent identification number that can be checked on the equipment)			
Description		Identification / registration #	
Description		Identification / registration #	
Description		Identification / registration #	
Description		Identification / registration #	

Hoses and Fittings

Notes:

1. Identify the type of hoses and fittings used, eg, solid moulded hose, lay-flat hose. Enter each type of hose or fitting on a new line.
2. Circle either 'yes' or 'no' to state whether the type of hose or fitting is suitable for the purpose of delivering potable water.

Type of hose or fitting used		Suitable for delivering potable water?	Yes		No	
Type of hose or fitting used		Suitable for delivering potable water?	Yes		No	
Type of hose or fitting used		Suitable for delivering potable water?	Yes		No	
Type of hose or fitting used		Suitable for delivering potable water?	Yes		No	
Type of hose or fitting used		Suitable for delivering potable water?	Yes		No	

2. Have there been any changes or additions to water sources used, vehicle(s) or equipment since your registration was last renewed?

	Please tick (✓)
Yes	
No	

If yes, describe below.

If no, do you certify that all registration details relevant to the water carrier in the current version of the Drinking-Water Supply register are true and correct?

	Please tick (✓)
Yes	
No	

Renewal of water carrier registration requires a compliance certificate from a Drinking Water Assessor, no more than three months old. Please attach a copy of this certificate.

Signed _____ (person responsible)

If you require help completing this form, please contact the drinking water assessor at your local District Health Board.

Application to Medical Officer of Health for Authorisation to Operate as a Temporary Water Carrier

Health (Drinking Water) Amendment Act 2007, Section 69ZI

Name of person applying to operate as a temporary water carrier:			
Address:			
Phone:		Fax:	
E-mail:		Date:	

- 1. Enter details in the box below that will describe and uniquely identify the vehicle(s) / tank(s) / vessel(s) / rail wagon(s) to be used.**

Description	Registration / Identification #

- 2. Explain why there is a need for a temporary water carrier and where water will be delivered.**

- 3. Enter the duration of use of temporary water carrier.**

Expected start date:	/ /
Expected finish date:	/ /
Estimated population served:	

4. List all sources of water that will be used (where you be filling from) and comment on what is known about the quality of the water (attach copies of any test results you may have).

Name / description / location of water source <i>(it is helpful if you attach a map)</i>	Information on water quality

5. Will you treat the water in any way? If yes, please provide a description of the treatment.

6. Has the water tanker (or vessel used to carry the water) been used previously for transporting any noxious, toxic or hazardous matter, non-food liquids or human or animal wastes?

	Please tick (✓)
Yes	
No	
Don't know	

7. Describe any procedures used to clean and disinfect the tanker prior to use (include detail of chemicals used and dilutions).

8. Do you certify that the vehicle / tanker / vessel / rail wagon identified in this application is suitable for the purpose of delivering potable water? *(Please circle)*

	Please tick (✓)
Yes	
No	

Signed _____

(print name)

_____ (signature)

Office use only	DWA assigned Checked by DWA on (date) / / Signature (DWA)	
------------------------	---	--

If you require help in completing this form, please contact the drinking water assessor at your local District Health Board.

Tankered Drinking-Water Carrier

Water carrier address:					
Phone:		Fax:		Email:	
Water carrier registration number:				Tanker ID:	
Date:				Docket no:	
Customer address:					
For the supply of:					

Source	Volume of water	Class	Treatment plant grading*	Network grading*

Notice to commercial clients

Please display this statement in a prominent place where customers can read it.

District Medical Officer of Health's advice on roof collected water stored in tanks for drinking and household use.

Water contamination can cause illness (diarrhoea and vomiting) which can be particularly dangerous especially for infants, very old people or people with damaged immune systems. Water contamination can be from bird, possum or other animal droppings on the roof or dead animals and insects in the gutter and tank itself. Delivery of water by tanker will disturb the sediment lying in the bottom of the tank. Allow the water to settle and clear before using it for drinking or cooking.

To prevent contamination of the tank, install a gutter mesh and cover the tank openings to prevent animals, birds or other matter from entering. Roof areas should be kept clear of overhanging vegetation to prevent leaves and debris falling on to the roof and to help prevent rodents, cats and possums having access to the roof or to allow birds to roost nearby.

Tanks should be inspected annually and cleaned if necessary but tank cleaning should ideally be carried out by a tank cleaning contractor.

More information can be found in the Ministry of Health publication on "Water Collection Tanks and Safe Household Water" (Code: 10148) or contact you local council, Public Health Unit or Drinking Water Assessor.

Signed:		Date:	
----------------	--	--------------	--

Please note that this is not a tax invoice but issued as a requirement under the Drinking-water Standards for New Zealand 2005.

Gradings explained on reverse of form.

Source and treatment grading

Assessment based on source and treatment factors will result in a grade:

- A1** Completely satisfactory, negligible level of risk, demonstrably high quality
- A** Completely satisfactory, extremely low level of risk
- B** Satisfactory, very low level of risk when the water leaves the treatment plant
- C** Marginally satisfactory, low level of microbiological risk when the water leaves the treatment plant, but may not be satisfactory chemically
- D** Unsatisfactory level of risk
- E** Unacceptable level of risk

Distribution zone grading

Assessment based on reticulation condition, management and water quality will result in a grade:

- a1** Completely satisfactory, negligible level of risk, demonstrably high quality
- a** Completely satisfactory, extremely low level of risk
- b** Satisfactory, very low level of risk
- c** Marginally satisfactory, moderate level of risk
- d** Unsatisfactory level of risk
- e** Unacceptable level of risk

If you require help in completing this form, please contact the drinking water assessor at your local District Health Board.

Application for Water Supply Registration

(For Network, Bulk, Port/Airport and Self-supplies that elect to register)
 Health (Drinking Water) Amendment Act 2007, Section 69K

Please tick (✓).

- This is a new registration
- This is a modification to an existing registration

Name of supply:	
Supply owner: (may be a company/organisation)	

Name of person responsible: (must be a named individual)			
Position:			
Address:			
Phone:		Fax:	
Email:			

Name of contact person/organisation:			
Position:			
Address:			
Phone:		Fax:	
Email:			

Supply type/nature of supply (please tick ✓)

- | | | | |
|-------------------|--------------------------|-----------------------|--------------------------|
| Network supply | <input type="checkbox"/> | Port/airport | <input type="checkbox"/> |
| Bulk supply | <input type="checkbox"/> | Specified self supply | <input type="checkbox"/> |
| Prescribed supply | <input type="checkbox"/> | | |

Maximum daily volume supplied:		m ³ /day
---------------------------------------	--	---------------------

Community

Name:		C Code:	
Normal population:			
Seasonal changes in population:	Yes		No
Describe seasonal changes if any:			

Distribution zone(s)

DZ Code:		DZ Code:		DZ Code:	
Name:		Name:		Name:	
GPS:		GPS:		GPS:	
Population:		Population:		Population:	

Treatment plant(s) and source(s)

TP Code:		TP Code:		TP Code:	
Name:		Name:		Name:	
GPS:		GPS:		GPS:	
Location description:		Location description:		Location description:	

S Code*:		S Code*:		S Code*:	
Name:		Name:		Name:	
GPS:		GPS:		GPS:	
Location description:		Location description:		Location description:	

S Code*:		S Code*:		S Code*:	
Name:		Name:		Name:	
GPS:		GPS:		GPS:	
Location description:		Location description:		Location description:	

S Code*:		S Code*:		S Code*:	
Name:		Name:		Name:	
GPS:		GPS:		GPS:	
Location description:		Location description:		Location description:	

Signed _____ (person responsible for supply)

Office use only	
Summary of action taken by DWA:	
Date form submitted to ESR:	/ /

Notes to accompany water supply registration form

Use this form:

To register a new or modify an existing drinking water supply (except tankered water supply).

Codes:

Do not enter any codes unless you are modifying the structure of a supply that is already registered.

* Enter the source type as the first letter of the SCODE:

R = Rainwater source

S = Surface water source

G = Groundwater source

Instructions:

Registrations of new supplies must include all names, populations and grid references. Use multiple pages where there are more than three zones or plants in a community. Indicate all plant / zone connections by connecting the blobs.

Map references:

The GPS should be in the NZTM seven digit grid reference system (eg, 2125670E, 5710600N).

If you require help in completing this form, please contact the drinking water assessor at your local District Health Board.

Application for Removal from Drinking-water Register

Application to Director-General of Health under the Health (Drinking Water) Amendment Act 2007,
 Section 69N

Name of drinking water supply or water carrier:	
--	--

List all applicable registration codes (from Drinking-water Register, eg, the codes for community, source, treatment plant, distribution zone where applicable)

--

Owner of supply or water carrier (may be a company/organisation)	
---	--

Person making application to have name removed:			
Position:			
Address:			
Phone:		Fax:	
E-mail:			

Date form completed:	/	/	Office use only
			Date registration entered: / /

Please outline why you are applying to be removed from the Register (attach copies of documents related to closure of business and clearly specify date when water ceased to be provided, if applicable).

--

Please be aware that the Director-General may retain on the Register all relevant details relating to the water supply activities of a person whose name has been removed from the Register, if the fact of that removal is clearly noted on the Register.

Form completed by:				<i>(print name)</i>
Signature:		Date:		

Office use only					
DWA recommendation on removal from Register					
DWA:					<i>(print name)</i>
Signature:		Date:			
DHB:					
Date form submitted to ESR:					

If you require help in completing this form, please contact the drinking water assessor at your local District Health Board.

Application to Medical Officer of Health to use Temporary Drinking-water Supply

Health (Drinking Water) Amendment Act 2007, Section 69ZI

Name of person applying to use temporary drinking-water supply:			
Position:			
Address:			
Phone:		Fax:	
E-mail:		Date:	

Name or description of temporary drinking-water supply:	
---	--

Explain why this temporary drinking-water supply is required.

Duration of supply

Expected start date:	/	/	Expected finish date:	/	/
Estimated population served:					

List all sources of raw water that will be used for the temporary drinking-water supply and comment on what is known about the quality of the raw water (attach copies of any test results you may have).

Name / description / location of raw water source (it is helpful if you attach a map)	Information on raw water quality

Will you treat the raw water in any way? If yes, please provide a description of the treatment.

Signed:		(print name)		(Signature)
----------------	--	--------------	--	-------------

Office use only	
DWA assigned:	
Assessment form completed on (date):	/ /
Signed:	(DWA)

If you require help in completing this form, please contact the drinking water assessor at your local District Health Board.

Application for Authorisation of Person(s) to Perform Drinking-water Analyses

In circumstances where Ministry of Health recognised laboratory is not used.
 Health (Drinking Water) Amendment Act 2007, Section 69ZP(1)(h)

Person responsible for drinking-water supply:			
Address:			
Phone:		Fax:	
E-mail:		Date form completed:	

1 Please complete the table below.

Name(s) of individuals to be authorised	Drinking-water analyse(s) to be undertaken by this individual (there is a list at the end of this form of common analyses, enter the associated letter, eg, (A) or state determinand and measurement method/equipment used)	Drinking-water supplies where this individual will undertake the stated analyses (state name and drinking-water register code)
1.		1. 2. 3. 4. 5.
2.		1. 2. 3. 4. 5.
3.		1. 2. 3. 4. 5.

2. Please state reason why it is not practicable to use a Ministry of Health recognised laboratory for these analyses.

Form completed by _____
(print name) (signature)

Date / /

List of drinking water analyses and test method

- (A) E. coli testing by Coliert™
- (B) E. coli testing by Colitag™
- (C) E. coli testing by B2P
- (D) Chlorine testing by DPD Colorimetric method using photometer
- (E) Chlorine testing by iodometric electrode technique
- (F) Chlorine testing by amperometric titration method
- (G) Chlorine testing by syringaldazine (FACTS) method
- (H) Chlorine testing by polarographic sensor method
- (I) Chlorine testing by electrochemical sensor (eg, ChloroSense by Palintest)
- (J) pH testing by electrometric method
- (K) pH testing by colorimetric method
- (L) Turbidity by nephelometric method

Office use only	Date application received DWA assigned Summary of actions taken by DWA	/ /
------------------------	---	----------------

Appendix 3: Cleaning Procedure Example

Purpose

This document provides an example of a cleaning procedure that can be used by tankers that have previously carried non-potable water such as sea or river water.

The actual cleaning procedure used by the TDWC must be submitted to the DWA for approval.

Tanker wash facility

1. Reticulated or potable water should be used for cleaning.
2. Check with the local authority where the tanker can be washed and the cleaning water discharged.
3. If required, use only food grade approved cleaners at the stated concentrations.
4. Allow one to two hours for this procedure.

Washing instructions

1. Drain the tank thoroughly.
2. If possible, open the tank and visually check the inside to make sure nothing is adhering to the sides. Scrape or hose out until the tank looks clean.
3. Wash and rinse with chlorinated solution, or any other approved formula (see Appendix 4), all hoses, vents and other removable items.
4. If required, use a high-pressure jet washer with proprietary food grade chemical cleaner at the recommended level to remove staining.
5. Hose out the tank from top down until no cleaning solution is detected.
6. Reseal the tank.
7. Half fill with water.
8. Add the requisite amount of chlorine solution to give a minimum 5 milligrams per litre (mg/L). For a 10,000 litre tank, this is 1.25 litres of domestic strength bleach (sodium hypochlorite at 4 percent strength) – see Appendix 4.
9. Continue to fill tank to the top and allow to overflow for a few seconds.
10. Leave for a minimum of 30 minutes (or preferably overnight) to ensure sterilisation.
11. Drain the tank thoroughly.
12. Flush or hose out dregs with clean water.

The tank should now be ready for transporting drinking-water.

Important note: There are safety issues associated with cleaning in confined spaces. Please ensure that any cleaning of your tank is carried out in accordance with occupational safety and health guidelines.

Appendix 4: Tanker Disinfection and Residual Chlorine Tests

The method of disinfection of the tanker and fittings using sodium hypochlorite or calcium hypochlorite (HTH) is shown below, together with the method for determining the chlorine content of the cleaning formula.

Sodium hypochlorite solution

The guidelines require all tanks and fittings that have been out of service for more than 30 days to be disinfected with chlorine or another approved disinfectant before they are put back into service. For ease of handling and safety, it is recommended that sodium hypochlorite be used as the disinfectant. A readily available commercial product can be purchased from many industrial chemical suppliers. The strength of the sodium hypochlorite is known (typically 15 percent available chlorine) at the time of sale. However, there can be a reduction in strength over time. Decomposition is due to storage at high temperature, exposure to sunlight and contaminants in the original product. Temperature and exposure to sunlight can be controlled, but contaminants cannot. For this reason, the shelf life of sodium hypochlorite is limited. Note any use-by date. The limited shelf life means that more than the stated dose may be needed to obtain the 5.0 milligrams per litre (mg/L) residual chlorine value in the tank being disinfected.

Hypochlorite is a powerful oxidising agent, is caustic and must be used with caution. Protective gloves and goggles must be worn when using sodium hypochlorite. Any spillages should be diluted immediately with copious amounts of water. Chlorine compounds must not be washed into a waterway because they are extremely toxic to aquatic life. Read the safety data carefully before using it.

Dechlorination can be carried out using sodium thiosulphate (for further details, contact your local DWA). TDWCs are required to obtain local authority approval prior to discharging the chlorinated water into a sewer. An alternative could be to irrigate the chlorinated water on to gravelled ground (on a sunny day) where there is good soakage and no chance of direct runoff into a waterway, but check with the local council. The chlorine disinfection requirement is 5.0 mg/L.

An alternative sodium hypochlorite product is available in supermarkets and sold as household bleach. The strength of these products ranges from 3–4 percent available chlorine. For those bleaches in the 3 percent range, that is, 30 g/L of sodium hypochlorite, five times the volume of solution will be required to equal the strength of the commercial sodium hypochlorite solution. A 4 percent solution will require less than five times the volume of the commercial product as shown below. To get 5.0 mg/L of FAC (free available chlorine) in a tank see Table 1 below.

Table 1: Disinfection dosing rates using sodium hypochlorite (NaOCl) solution

Tank volume, litres (m ³)	Volume of 15% sodium hypochlorite	Volume of 4% sodium hypochlorite	Volume of 3% sodium hypochlorite
1,000 (1 m ³)	35 mL	125 mL	170 mL
2,000 (2 m ³)	70 mL	250 mL	340 mL
5,000 (5 m ³)	170 mL	625 mL	840 mL
10,000 (10 m ³)	335 mL	1,250 mL	1,675 mL
15,000 (15 m ³)	505 mL	1,875 mL	2,515 mL
20,000 (20 m ³)	670 mL	2,500 mL	3,350 mL

Volumes are in millilitres (mL) and have been rounded upwards.

For ease of measurement, a plastic measuring cylinder or a graduated jug can be used because most tanks will be in the higher capacity range.

Note that where tank volumes are outside the range in Table 1 above, add the appropriate values together to obtain the desired tank volume and chlorine dose required.

To ensure even distribution of the chlorine in the tank, the hypochlorite solution should be added during the tank filling process and left for a minimum of 30 minutes before being emptied. Once the chlorine solution has been added and thoroughly mixed, a chlorine test must be carried out in accordance with the FAC test procedure described below. If the test result is higher than 5.0 mg/L, leave the tank for the required 30 minutes. If the test is lower than the required 5.0 mg/L, add more sodium hypochlorite solution and mix thoroughly and test again. Repeat the process until the required value of 5.0 mg/L is obtained.

Calcium hypochlorite

Calcium hypochlorite, is supplied as a loose powder, granules or tablet form and can be used as an alternative to sodium hypochlorite solutions. Calcium

generally known as high test hypochlorite, or HTH,

A commercial brand of HTH powder used in the disinfection of swimming pools is satisfactory. The active chlorine content is normally approximately 70 percent.

The dosing rate of chlorine associated with swimming pools is provided on the product label. However, it should be noted that because clean water with a negligible chlorine demand is being chlorinated in this procedure, those dosage levels may be much higher than needed, and therefore should not be used.

Different commercial brands might have different percentage chlorine values to that given in the information above. Check before proceeding.

Based on data contained on the commercial product label, the following quantity of powder will be required to meet the 5.0 mg/L requirement of FAC.

A 20 cubic metre (20,000 L) tank would require approximately 180 g of powder to give a minimum 5 mg/L FAC. This is equivalent to 12 tablespoons or three-quarters of a cup using cooking equivalent measures.

A 10 cubic metre (10,000 L) tank would require half this amount and so on.

Add the powder early during the filling process (see Appendix 3). The agitation achieved during filling should ensure that the powder is dissolved.

Determination of free available chlorine

Chlorine measurement for water used to wash the tank can be variable because of dosing rates, but must be at least 5.0 mg/L (sometimes expressed as 5 g/m³ or 5 ppm) FAC.

Recommended procedure

An example of a chlorine test kit using a comparator, which is a simple and effective means for measuring FAC in tankered water, is shown in Figure 3.

Figure 3: Example of chlorine test kit using a comparator and colour disc



Instructions

Full instructions are included with the commercial test kits. In summary, reagents (DPD tablets for measuring free available chlorine) are added to a measured sample of water in the unit and the resulting sample colour is matched with the coloured disc to indicate the concentration of the chlorine.

Range

The usual working range for the test kits is 0–10 mg/L FAC. However, it should be noted that chlorine is a powerful oxidising agent and is used as a bleaching agent. Therefore, if the sample being tested is from water that has been dosed incorrectly, and the actual level is much higher than that required (greater than 5.0 mg/L) then the colour produced by the addition of the tablet may be bleached from the sample as well. If in doubt, dilute the sample by a known amount to reduce the chlorine content and re-measure. Adjust the result to take account of the dilution. For example, if the sample was diluted 10:1 then multiply the answer by 10.

There are many chlorine test kits available, but only approved test kits will be accepted by the DWA. Contact the DWA for advice.

Safe handling and storage

Refer to the safety data sheet for storage and handling of all chemical products, particularly chlorine-based products.

Appendix 5: Delivery Docket Example

Logo may be inserted here

Company name
Company address

Telephone
Fax

Tankered Drinking-Water Carrier Listed in the Ministry of Health's Register for Community Drinking-water Supplies and Suppliers

Registration No

Tanker ID

Date	12 December 2008	Docket no	122344
Customer address			
For the supply of	One (1) load of drinking-water		
Source	Class	Treatment plant grading	Reticulation grading
Waiomea DC	1(a)	B (Satisfactory)	b (Satisfactory)

Notice to commercial clients

Please display this statement in a prominent place where customers can read it.

District Medical Officer of Health's advice on roof-collected water stored in tanks for drinking and household use:

Water contamination can cause illness (diarrhoea and vomiting) that can be particularly dangerous, especially for infants, very old people or people with damaged immune systems. Water contamination can be from bird, possum or other animal droppings on the roof, or dead animals and insects in the gutter and tank itself. Delivery of water by tanker will disturb the sediment lying in the bottom of the tank. Allow the water to settle and clear before using it for drinking or cooking.

To prevent contamination of the tank, install a gutter mesh and cover the tank openings to prevent animals, birds or other matter from entering. Roof areas should be kept clear of overhanging vegetation to prevent leaves and debris falling on to the roof and to help prevent rodents, cats and possums having access to the roof or to allow birds to roost nearby.

Tanks should be inspected annually and cleaned if necessary, but tank cleaning should ideally be carried out by a tank cleaning contractor.

Further information can be found in the Ministry of Health publication 'Water Collection Tanks and Safe Household Water' (Code: 10148) or contact your local council or public health unit.

Signed.....

Date.....

Please note that this is not a tax invoice but issued as a requirement under the Drinking-water Standards for New Zealand 2005.

Appendix 6: Tankered Drinking-water Carriers: Reference Guide to the Health (Drinking-Water) Amendment Act 2007

Introduction

The Drinking-water Standards for New Zealand (currently DWSNZ 2005), which provide standards for tankered water, came into effect 1 January 2006, superseding earlier standards. The DWSNZ 2005 sets out minimum standards, but also encourages the identification, managing and minimising of risks by adopting a public health risk management plan (PHRMP). Tankered drinking-water carriers are addressed in Section 11 of DWSNZ 2005 as they are part of the water supply chain. Carriers of Drinking-water in New Zealand must ensure that any water sold or supplied for potable purposes, that is, drinking, food preparation or personal hygiene, meets the requirements of this section and that the water is protected from contamination at all times during its loading, transit and delivery. The Health (Drinking Water) Amendment Act 2007 stipulates that all practical steps must be taken to comply with the DWSNZ 2005, with penalties for non-compliance.

This document provides easy-to-follow guidance of the important and specific parts of the legislation that will affect tankered drinking-water carriers. The guide has been divided into nine key areas:

1. The register for tankered drinking-water carriers
2. Duties of tankered drinking-water carriers
3. Public Health Risk Management Plans
4. Record keeping
5. Temporary supplier
6. Role of the drinking-water assessor
7. Offences
8. Penalties
9. Emergencies.

The relevant sections of the legislation are identified and summarised for those areas with words taken directly from the act. Ellipses '...' indicate where words have been omitted and brackets () indicate where words have been inserted, to help clarify each point. What this means for the carrier has been summarised alongside those sections.

1 The Register for Tankered Drinking-water Carriers

Sections of the Act

- 69G – Interpretation
- 69J – Drinking-water register
- 69K – Applications for registration
- 69L – Renewal of registration by water carriers
- 69M – Duty to update details on register
- 69N – Removal from register

Summary of the legislation

Drinking-water supplier means a person who supplies drinking water to people in New Zealand or overseas from a drinking-water supply, and – (a) includes that person's employees, agents, lessees and subcontractors while carrying out duties in respect of that drinking-water supply; and (b) includes (without limitation) – (i) a networked supplier; and (ii) a water carrier ...

The Director-General of Health must maintain a register of persons who are water carriers. All existing water carriers must be recorded on the register by 1 July 2008. It is an offence to supply or transport water if not registered for more than five days in any 12-month period.

The following particulars must be recorded in the register in respect of every drinking-water supplier registered as a water carrier:

- (a) the name and contact address (including the electronic address, if available) of the carrier
- (b) the date on which the water carrier was registered and the date of each renewal of that person's registration
- (c) the source or sources of raw water or drinking water that is transported by the water carrier
- (d) prescribed particulars relating to each vehicle, ... (and any associated equipment such as demountable tanks, hoses and fittings) used by a water carrier to transport raw water or drinking-water
- (e) any other particulars that may be required ...

On the form provided by the Director-General of Health every person registered as a water carrier must apply in each 12-month period for a renewal of registration as a water carrier. The application must be accompanied by (a) a certificate, from a drinking-water assessor, no more than three months old, stating that the drinking-water assessor has assessed the practices and procedures of the water carrier and certifies that those practices and procedures comply and (b) the prescribed particulars for each vehicle and any associated equipment such as demountable tanks, hoses and fittings.

The Director-General of Health may refuse to renew the registration of a person as a water carrier if the Director-General of Health is satisfied that the water carrier has failed, or is unable, to comply with the requirements.

A water carrier who intends to cease operation as a carrier or to change any particulars that are recorded in respect of that person or in respect of any vehicle or vessel, including any associated equipment such as demountable tanks, hoses and fittings, for the purposes of water transportation must notify the Director-General of Health, in writing as soon as practicable, of the change and the proposed date of the change.

- (1) The Director-General of Health must remove a person's name from the drinking-water register if –
 - (a) that person is registered as a water carrier and applies to the Director-General of Health, in writing, to have that person's name removed from the register; and
 - (b) the Director-General of Health is satisfied that the person has ceased to carry on business as a water carrier.
- (2) The Director-General of Health may remove the name of any person registered as a water carrier from the drinking-water register if the Director-General of Health is satisfied that the water carrier:
 - (a) has failed to comply with the requirements of this Part; or
 - (b) is unable to comply with the requirements of this Part.
- (3) Despite subsections (1) and (2) of section 69N, the Director-General of Health may retain on the register all relevant details relating to the water-supply activities of a person whose name has been removed from the register, if the fact of that removal is clearly noted on the register to avoid any confusion.

What it means and what to do

From 1 July 2008, in order to carry water for more than five days of the year, the carrier must be registered. See section 4 of the guidelines for further information.

Contact your local drinking-water assessor as soon as possible to arrange the process for assessment and registration. Drinking-water assessors can be contacted at the local public health unit of your District Health Board. They will give you a form to complete. The registration form will require a list of the equipment used such as tank and pipe and fittings as well as your details. Fill it in and return to the drinking-water assessor as early as possible before 1 July 2008. The Director General of Health will then write to you confirming that you are registered and issue you with a certificate.

You need to renew your registration every year. Contact your drinking-water assessor up to three months before the registration certificate runs out. Obtain a renewal form from the drinking-water assessor and reapply for registration. The drinking-water assessor will visit you and reassess your operation.

Carriers also need to keep the drinking-water assessor informed of any substantial changes to their operation such as replacing trucks or tanks or if they stop trading.

A carrier may also be removed from the register if they fail to comply with the legislation.

2 Duties of the Tankered Drinking-water Carriers

Sections of the Act

69T – Duties where risk to water is actual or foreseeable

69V – Duty to take all practicable steps to comply with Drinking-water Standards

69W – Duty to take reasonable steps to supply wholesome drinking water

69Y – Duty to monitor drinking-water

69ZF– Duty to take remedial action if Drinking-water Standards breached

Summary of the legislation

69T If any drinking-water supplier considers that its ... supply of drinking water is or may be at imminent risk for any reason, it must – '(a) notify the medical officer of health ...'

69V(1) Every drinking-water supplier must take all practicable steps to ensure that the drinking-water supplied by that supplier complies with the current and valid drinking-water standards.

69V(1A) A drinking-water supplier complies with subsection 69V(1) if the supplier implements those provisions of the supplier's approved public health risk management plan relating to the drinking-water standards.

69V(2) Subsection 69V(1) applies to each drinking-water supplier subject to any exemption or variation that has been granted to that supplier ... (ie, in an emergency).

69W Every drinking-water supplier must take reasonable steps ensure that the drinking-water supplied by that drinking-water supplier is wholesome.

69Y (A drinking-water supplier) ... must monitor the drinking water supplied to determine whether it complies with the drinking-water standards ... and detect and assess public health risks generally. Monitoring must be carried out in accordance with the drinking-water standards.

69ZF Every drinking-water supplier who becomes aware that the drinking water supplied by ... a water carrier, is not meeting the drinking-water standards must – (a) take all practicable steps to carry out the appropriate remedial action set out in the drinking-water standards to correct the problem; or (b) if no remedial action is set out in the drinking-water standards, take all practicable steps to correct the problem.

What it means and what to do

Under the legislation, carriers have duties or obligations including the duty to monitor the drinking-water quality and to implement a risk management plan (see section 7.3 of the guidelines).

If the water being carried is from a chlorinated reticulated supply, carriers must have the water tested for *E. coli* every third month. See section 6.0 of the guidelines.

Carriers must take all practicable steps to ensure that the drinking-water supplied complies with the drinking-water standards and reasonable steps are taken to supply wholesome drinking-water. 'Practical' and 'reasonable' steps used in law are subject to interpretation, but do include an element of affordability.

3 Public Health Risk Management Plans

Sections of the Act

- 69Z – Duty to prepare and implement public health risk management plans (PHRMP)
- 69E – The date by which a water carrier must comply
- 69ZB – Duration of plans
- 69ZC – Review and renewal of plans
- 69ZG – Duty to provide reasonable assistance to drinking-water assessors, designated officers and medical officers of health

Summary of the legislation

Every drinking-water supplier must:

- ... on or before the date on which this section begins to apply, prepare in writing ... in the case of a drinking-water supplier who is a water carrier, a PHRMP in relation to that water carrier's method of transporting raw water or drinking water
- ... identify mechanisms for preventing public health risks; and reducing and eliminating those risks if they do arise; ... and sets out a timetable for managing the public health risks that have been identified as being associated with that method of transportation; and (v) comply with any additional requirements imposed by the Director-General by notice in writing given to the water carrier as to the content and format of public health risk management plans (including, without limitation, any requirement contained in a model plan issued by the Director-General)
- ... public health risk management plan must be submitted by the drinking-water supplier to a drinking-water assessor for approval.

A drinking-water assessor ... must, within 20 working days after receiving a PHRMP ... decide to approve or disapprove it; or require its alteration within a specified period; or require the provision of further information within a specified period. If a drinking-water assessor does not approve a PHRMP, the assessor must notify the drinking-water supplier and give reasons for the non-approval.

Every drinking-water supplier or temporary drinking-water supplier must, at all reasonable times, provide reasonable assistance to a medical officer of health.

Every drinking-water supplier or temporary drinking-water supplier who is required to prepare a PHRMP must ... keep records that contain sufficient information to enable a drinking-water assessor to ascertain whether or not that drinking-water supplier or temporary drinking water supplier is complying with the requirements of – (i) this part; and (ii) the drinking-water standards; and (iii) that drinking-water supplier's or temporary drinking-water supplier's PHRMP; and (b) keep records of any other risk management plan relevant to that supplier's supply.

What it means and what to do

Carriers are required to prepare and implement a PHRMP. See Section 7.3 of the guidelines for further details. A sample template is appended to the guidelines.

There is a timeframe by which you must have a PHRMP and comply with drinking-water standards, particularly with reference to sampling. This is dependent on your water supplier. The larger the supplier the sooner they need to comply. Check with your water supplier to find out when you need to comply. If you are not sure, contact your drinking-water assessor.

The PHRMP must be submitted to the drinking-water assessor for approval, who has specific timeframes to work within (20 days). Implementation of the PHRMP needs to start within one month after it has been approved.

The PHRMP, once approved and implemented, remains in force for the period stated in the plan or for a maximum duration of five years if there are no major changes identified.

For renewals, you must submit revised plans no later than two months before the plan is due to expire.

4 Record keeping

Sections of the Act

- 69ZD – Duty to keep records and make them available
- 69ZE – Duty to investigate complaints
- 69ZZ – Compliance tests must be carried out by recognised laboratory

Summary of the legislation

In the case of a water carrier, the records kept must include –

- (a) details of the steps taken by the water carrier to protect from contamination any raw water carried and to protect from contamination any drinking water before or during transportation;
- (b) details of the monitoring of that raw water or drinking water;

- (c) details of any complaints received in relation to that raw water or drinking water, and the actions taken in relation to those complaints; and
 - (d) all the information required to be kept by regulations made under this Act for each vehicle, vessel or rail wagon used to transport water.
- (4) Records kept under this section must be made available to a drinking-water assessor, on request. Every drinking-water supplier who receives a complaint about the quality (including the wholesomeness) of the drinking water supplied by that supplier, or, transported by that supplier in the supplier's capacity as a water carrier, must investigate that complaint and, –
- (a) if the complaint relates to the wholesomeness of the drinking water and is upheld, take all reasonable steps to improve the wholesomeness of that drinking water; or
 - (b) if the complaint relates to a failure to meet the drinking-water standards and is upheld, take the appropriate remedial action specified in section 69ZF.

What it means and what to do

In addition to the delivery dockets outlined in section 7 of the guidelines, details of complaints received must be recorded.

If the carrier becomes aware that the quality of the water is not meeting the standards – the supplier must take all practicable steps to correct the problem.

All water samples must be analysed by a Ministry of Health recognised laboratory. All recognised laboratories are registered on the Ministry of Health and ESR website.

5 Temporary supplier

Sections of the Act

69ZI – Temporary supplier to notify medical officer of health of source and quality of raw water

69ZJ – Powers of medical officer of health relating to temporary drinking-water suppliers

Summary of the legislation

69ZI(1) Every temporary drinking-water supplier must advise the medical officer of health, in writing, of –

- (a) each source of raw water to be used by that supplier to supply drinking water; and
- (b) the quality of the raw water taken from that source.

(2) The advice referred to in subsection (1) must be given –

- (a) as early as practicable before the supplier begins to supply drinking water from raw water taken from the source; or

- (b) as soon as practicable after the supplier has begun supplying raw water taken from the source as drinking water if, due to an unforeseen event, it is necessary, as a matter of urgency, to supply drinking water that was raw water taken from the source.

69ZJ(1) A medical officer of health may, by notice in writing, impose reasonable requirements on a temporary drinking-water supplier to monitor the drinking water supplied by that supplier.

(2) A medical officer of health may, by notice in writing, prohibit a temporary drinking-water supplier from supplying drinking water from a particular source.

(3) A temporary drinking-water supplier must comply with a notice issued to that supplier under subsection (1) or subsection (2).

What it means and what to do

Drinking-water assessors may impose certain requirements on a temporary drinking-water supplier, for example, at music festivals, or other large gatherings.

6 Role of the drinking-water assessors

Sections of the Act

69ZP – Powers of drinking-water assessors and designated officers

69ZQ – Ancillary powers

69ZR – Restrictions on exercise of powers

69ZU – Drinking-water assessors and designated officers must produce identification

69ZW – Review of decisions of drinking-water assessors

Summary of the legislation

A drinking-water assessor or designated officer may ... enter ... inspect ... records ... and require a drinking-water supplier to supply any information ... relating to ... compliance with the drinking-water standards; and implementation of that drinking-water supplier's PHRMP; and require, by notice in writing, any person who has possession or control of information, records, or documents ... to supply to the drinking-water assessor or the designated officer, in a manner specified in the notice, all or any of that information, or all or any of those records or documents; and ... conduct inspections investigations, direct any drinking-water supplier to conduct any inspections, that are reasonably necessary; and take samples; and) take steps to verify the competence of persons who have performed tests ... provide information obtained from drinking-water suppliers under this part to the Director-General of Health.

When entering land, a drinking-water assessor or designated officer may – be accompanied and assisted by any other person; and take on to the land or into the building, vehicle, vessel or rail wagon, any appliances, machinery and equipment reasonably necessary to carry out the drinking-water assessor’s functions or the designated officer’s functions, as the case may be. Any person who accompanies or assists a drinking-water assessor or designated officer under this section may act only under the supervision or in accordance with the instructions of the assessor or officer.

The Director-General of Health must provide an identity card to each drinking-water assessor and each designated officer ... designated officer must, on request, produce the identity card or other means of identification for inspection. Whenever a drinking-water assessor or designated officer enters any land, building, vehicle, vessel, or rail wagon ... and is unable, despite reasonable efforts, to find any person apparently in charge, he or she must before leaving that place leave a written notice stating – (a) his or her identity; and ... (b) an address where he or she may be contacted; and (c) the date and time of entry and (d) his or her reasons for entering.

- (1) A drinking-water supplier may request a review by the Director-General of Health of any of the following decisions by a drinking-water assessor (a) a finding, assessment, or recommendation in relation to the compliance of that drinking-water supplier with the requirements of this part, that drinking-water supplier’s public health risk management plan, or the drinking-water standards; or (b) a refusal to approve that drinking-water supplier’s public health risk management plan, or to certify its implementation.
- (2) Any request for a review made under this section must be forwarded to the Director-General of Health within two months after the date when the decision of the drinking-water assessor is made known to the drinking-water supplier.
- (3) The Director-General of Health must, after seeking any advice that he or she considers necessary, confirm, vary, or reverse the decision of the drinking-water assessor.

What it means and what to do

Drinking-water assessors have the right to inspect the records and require information to ensure that the standards are being complied with.

Carriers may request a review by the Director-General of Health of any decision made by the drinking-water assessor within two months of the decision made.

7 Offences

Sections of the Act

- 69ZZQ – Offence to supply or transport water
- 69ZZR – Offences against sections in this part
- 69ZZT – Offences involving deception

Summary of the legislation

69ZZR(1) Every person commits an offence who contravenes, any of the following: (a) section 69U (duty to protect source of drinking water); (b) section 69V (duty to take all practicable steps to comply with drinking-water standards); (c) section 69Y (duty to monitor drinking-water); (d) section 69Z (duty to prepare and implement public health risk management plan); (e) section 69ZA(5) (duty of certain drinking-water suppliers or temporary drinking-water suppliers to prepare and implement a PHRMP if required to do so); (f) section 69ZF (duty to take remedial action if drinking-water standards breached); (g) section 69ZZD(3) (duty to comply with requirements of a designated officer acting under emergency powers).

69ZZR(2) Every person commits an offence who contravenes, or permits a contravention of, any of the following: (a) section 69ZD (duty to keep records and make them available); (b) section 69ZG (duty to provide reasonable assistance to drinking-water assessors, designated officers, and medical officers of health); (c) section 69ZZI (compliance with compliance order).

69ZZR(3) Every person commits an offence who contravenes, or permits a contravention of, any of the following: (a) section 69K (applications for registration); (b) section 69L (renewal of registration by water carriers); (c) section 69M (duty to update details on register); (d) section 69S (duty of suppliers in relation to provision of drinking water); (e) section 69T (duties where risk to water is actual or foreseeable); (f) section 69X (duty to test new water sources); (g) section 69ZI (duty to notify medical officer of health of source and quality of raw water).

69ZZR(4) Every person commits an offence who, without reasonable excuse, takes any water from a fire hydrant, unless ... has the written approval of the drinking-water supplier who supplies water to the hydrant.

- (1) Every person commits an offence who, with intent to deceive, – (a) makes any false or misleading statement or any material omission in any communication, record, or return for the purpose of this part or the drinking-water standards; or (b) destroys, cancels, conceals, alters, obliterates, or fails to provide, any document, record, return, or information that is required to be kept or communicated under this part or under the drinking-water standards; or (c) falsifies, removes, suppresses, or tampers with any samples, test procedures, test results, or evidence taken by a drinking-water assessor in the exercise of that drinking-water assessor's functions or powers under this part; or (d) falsifies, removes, suppresses, or tampers with any samples, test procedures, or test results taken under, or for the purposes of, – (i) the drinking-water standards; or (ii) a drinking-water supplier's PHRMP.

- (2) Every person who commits an offence against subsection (1) is liable to the penalty set out in section 69ZZV(1).

What it means and what to do

It is an offence to carry water for more than five days of the year if you are not registered except in an emergency, or to take practicable steps to comply with the drinking-water standards.

Amongst others, it is also an offence to take water, for example, from a fire hydrant without written permission.

Use the Tankered Drinking-water Guidelines to help you to comply with the legislation.

It is an offence to mislead any designated officer or to provide any false material or statements.

8 Penalties

Sections of the Act

69ZZV – Penalties

69ZZW – Additional penalty for certain offences for commercial gain

Summary of the legislation

Every person who commits an offence against section 69ZZR(1) or 69ZZT is liable to summary conviction to a fine not exceeding \$200,000 and, if the offence is a continuing one, to a further fine not exceeding \$10,000 for every day or part of a day during which the offence continues.

Every person who commits an offence against section 69ZZR(2) is liable on summary conviction to a fine not exceeding \$10,000 and, if the offence is a continuing one, to a further fine not exceeding \$1,000 for every day or part of a day during which the offence continues.

Every person who commits an offence against section 69ZZR(3) or (4) is liable on summary conviction to a fine not exceeding \$5,000.

The continued existence of any thing, or the intermittent repetition of any action, that constitutes an offence under section 69ZZR is a continuing offence for the purposes of this section. If a person is convicted of an offence producing a commercial gain, in addition to any other penalty the court may order that person to pay an amount not exceeding – (a) three times the value of any commercial gain resulting from the commission of the offence; (b) if the person is a body corporate, and the value of any gain cannot be readily ascertained, 10 percent of the turnover of the body corporate and all of its interconnected. 1) In any prosecution for an offence under section 69ZZQ or 69ZZR, it is not necessary to prove that the defendant intended to commit the offence.

What it means and what to do

The penalty for not being registered but carrying water for more than five days of the year is up to \$10,000 and then \$1,000 for each day the offence continues.

Other penalties range up to \$200,000 depending on the offence.

9 Emergencies

Sections of the Act

69ZO – Ability of designated officers to take actions to protect public health

69ZZA – Minister may declare drinking-water emergency

69ZZD – Special powers of designated officers during drinking-water emergency

Summary of the legislation

A designated officer ... (who) ... believes, on reasonable grounds, that there is a serious risk to public health arising from the drinking water supplied to those people, or from a lack of drinking water available to those people; may exercise ... powers ... (and) ... may take immediate action, or to require any person to take immediate action, to prevent, reduce, or eliminate any risk to public health arising from a drinking-water supply: require any drinking-water supplier to stop supplying drinking-water that has not been treated to make it potable: require all persons within a specific area to use an alternative drinking-water supply: for the purpose of protecting the public, publish statements relating to the serious risk of harm to health or safety, including, without limitation, statements about the boiling of water.

A designated officer must take all practicable steps to consult with affected drinking-water suppliers before exercising a power referred to ... and ... in every case, take all reasonable steps to comply with rules relating to health and safety at any place in each situation.

If the Minister believes, on reasonable grounds, that there is a serious risk of harm to the health or safety of any people arising from the drinking water supplied to those people, or from a lack of drinking water available to those people, the Minister may declare a drinking-water emergency in relation a drinking-water supply.

A designated officer may ... grant to any drinking-water supplier or other person a conditional or unconditional exemption from the duty to comply with all or any of the provisions of this part or the drinking-water standards during the period of the drinking-water emergency.

What it means and what to do

The designated officer can stop the supply of drinking water if there is a serious risk to public health.

Alternatively, in an emergency, the designated officer can exempt carriers from the duty to comply with the drinking-water standards, allowing carriers to supply water.

Appendix 7: Customer Notification Example

(LOGO)

NOTE TO CUSTOMERS AND CUSTOMERS

Date:

Dear Customer

Delivery of your latest order for drinking-water has now been completed.

During the filling process, it was observed that the contents of your tank became discoloured when the new drinking-water was added. The water delivered today meets the New Zealand Drinking-water Standards for New Zealand and may have become contaminated with matter that was in your tank at the time of filling.

Any discolouration or sediment that you may observe at your tap will be a result of sediment and other matter in your tank mixing with the drinking-water that has been delivered to you.

Because roof water can become contaminated with a variety of chemicals and micro-organisms, some of which may cause illness, it is recommended that you either flush your tank before the next fill or obtain the services of a specialised contractor who can do this job for you and who may also be able to advise you on the best method of future maintenance of your tank.

It is important that, wherever possible, dirt and debris be diverted from tanks and sludge not be allowed to accumulate. It is recommended that all new tanks are fitted with suitable drain valves to enable any accumulated sludge or solids to be removed on a regular basis.

This note is being left for you in the best interests of your family's health. It is in no way a directive because we are only the carriers of drinking-water.

For further information, please contact the local public health unit at your District Health Board and ask to speak to the Drinking-water Assessor who can provide guidance on what steps you should take to ensure that your roof-tank drinking-water supply is safe to drink.

Appendix 8: Key Contacts (DWAs)

Northland District Health Board

Community Dental and Public Health Services
Ground Floor, Dairy House
Porowini Avenue
PO Box 742
WHANGAREI
Tel: (09) 430 4100

Auckland District Health Board

Auckland Regional Public Health Service
Cornwall Complex – Building 15
40 Claude Road
Greenlane
Private Bag 92605 Symonds Street
AUCKLAND 1035
Tel: (09) 623 4600

Waikato District Health Board

Health Waikato
Level 4 Hugh Monckton Trust Building
Cnr Rostrevor and Harwood Street
HAMILTON
PO Box 505
Hamilton
Tel: (07) 838 2569

Bay of Plenty District Health Board

Toi Te Ora Public Health Unit (servicing Bay of Plenty and Lakes District Health Boards)
Corner Garaway and Stewart Streets
PO Box 241
WHAKATANE
Tel: (07) 306 0847

Tairāwhiti District Health Board

Public Health Unit
3rd Floor, Morris Adair Building
Gisborne Hospital
421 Ormond Road
Private Bag 7001
GISBORNE 4040
Tel: (06) 867 9119

Taranaki District Health Board

Public Health Unit
Barratt Building
Tukapa Street
Private Bag 2016
NEW PLYMOUTH 4620
Tel: (06) 753 7799

MidCentral District Health Board

Public Health Unit
Community Health Village
Palmerston North Hospital
PO Box 2056
PALMERSTON NORTH
Tel: (06) 350 9110

Hawkes Bay District Health Board

Public Health Unit
Napier Health Centre
76 Wellesley Road
PO Box 447
NAPIER
Tel: (06) 834 1815

Hutt Valley District Health Board

Regional Public Health Service
Level 1, Community Health Building
Hutt Hospital
Private Bag 31 907
LOWER HUTT
Tel: (04) 570 9002

Nelson–Marlborough District Health Board

Nelson Public Health Unit
36 Franklyn Street
PO Box 647
NELSON
Tel: (03) 546 1537

Canterbury District Health Board

Community and Public Health Service
Datacom House
76 Chester Street East
PO Box 1475
CHRISTCHURCH
Tel: (03) 379 9480

Otago–Southland District Health Board

Public Health South
Te Wakahauora
57 Hanover Street
PO Box 5144
Moray Place
DUNEDIN
Tel: (03) 474 1700

Appendix 9: Example Public Health Risk Management Plan

EXAMPLE

Tankered Drinking Water Carriers

**PUBLIC HEALTH RISK
MANAGEMENT PLAN**

for

[insert name of carrier]

This document was prepared by.....

This document was prepared on

This document is due for revision

This document was approved by Water Supply Owner

ORGANISATION DETAILS

1 **Supply owner/organisation name:**

Contact person:

Postal address:

Contact: phone number:

Contact fax number:

Contact email address:

2 **Operator(s):**

Contact person:

Postal address:

Contact: phone number:

Contact fax number:

Contact email address:

3 **Water supply information:**

Water supply to be used:

INTRODUCTION

- Purpose of PHRMP.
- Review of PHRMP information and frequency.
- Business information, eg, size of business, number of tankers, number of drivers, where tankers kept, description of tankers, frequency of operation.
- Proposed filling points (including community code, if not registered supply them this must be done), also local authority approval.
- Aim to comply with section 11 of DWSNZ 2005 and section 69E of H(DW)AA.
- Identification of three main risk areas of operation (water collection, transport and delivery).

STEP 1: WATER SUPPLY DESCRIPTION

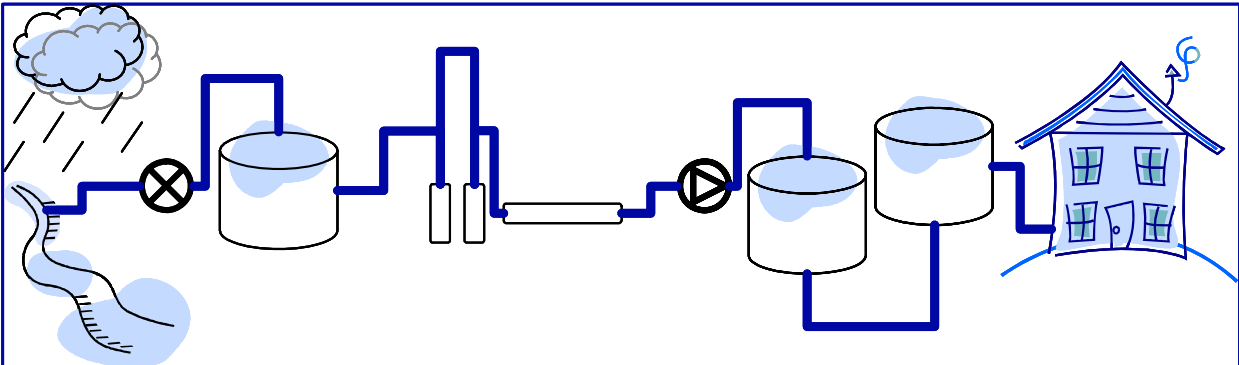

A good description of your water supply starts the process of identifying what could cause the water to become unsafe to drink.

The description should include a flow or schematic diagram of the physical water supply system, including the catchment, intake, transfer to the treatment plant, the treatment process, storage facilities and distribution. The description should also include an outline of what the various people and organisations do in managing, operating and maintaining the water supply. Also record the volume and quality requirements of consumers.

You can refer to other documents such as maps and technical drawings to avoid duplication. The use of photographs to illustrate key features is a good idea.

The blank flow charts on the following pages may be a useful way to record your description. Walk the supply and check that you have a good description.

Flow chart – final version

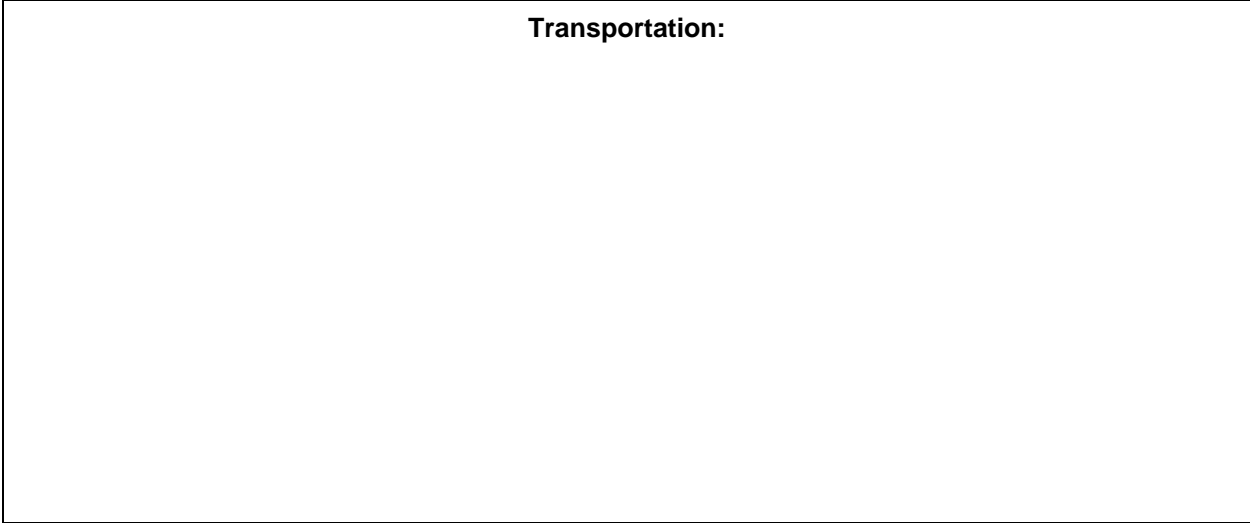

STEP 2: PRIORITISING WHAT NEEDS ATTENTION

This section helps you to prioritise what needs attention, because you usually cannot deal with everything at once. In general, priority should be given to the events that will make people sick and will more than likely happen.

Your notes in the previous section - *Water Supply Assessment* - will help you. **Write the events that could cause the water to become unsafe to drink (including not enough water) in the first column of the tables in this section. Then fill in the rest of the tables.**

Some of these events will already be adequately managed by routine inspections and maintenance. Other events will be “an accident waiting to happen” with no plan in place of how to improve the situation. Some of these events will be more likely to happen than others, and some are more likely than others to make people sick.

The tables over the page may be useful to judge priorities – follow steps 1 then 2 then 3. Alternatively, your gut feeling may be an OK way to judge priorities.

Judging priorities

1. For each event, decide on the **likelihood** of it happening.

Likelihood score	Possible descriptions
Almost certain	<ul style="list-style-type: none">• Occurs like clockwork.• Occurs every week, month, or season.
Likely	<ul style="list-style-type: none">• Has occurred more than once before.• Expected to occur every year.
Possible	<ul style="list-style-type: none">• Has occurred before.• Expected to occur every 2–5 years.
Unlikely	<ul style="list-style-type: none">• Has never occurred before, but expected to occur every 5–10 years.
Rare	<ul style="list-style-type: none">• Has never occurred before, and expected to occur less than once every 10 years.

2. For each event, decide on the **consequence** to people's health if it did happen.

Consequence score	Possible descriptions
Insignificant	<ul style="list-style-type: none"> No illness expected in the community.
Minor	<ul style="list-style-type: none"> Very few of the community ill.
Moderate	<ul style="list-style-type: none"> Some of the community ill
Major	<ul style="list-style-type: none"> Most of the community ill.
Catastrophic	<ul style="list-style-type: none"> All of the community ill. Anticipate some deaths.

3. For each event, look up the **likelihood** and **consequence scores** in this table to find the corresponding **priority**.

Likelihood	Consequence				
	Insignificant	Minor	Moderate	Major	Catastrophic
Almost certain	Medium	Medium	High	High	Very high
Likely	Medium	Medium	Medium	High	High
Possible	Very low	Low	Medium	High	High
Unlikely	Very low	Very low	Low	Medium	High
Rare	Very low	Very low	Low	Medium	Medium

Collection of water

Describe what could cause water to become unsafe to drink (including not enough water)	Is this under control now? If so, describe how it is being controlled.	If not, judge whether the PRIORITY for attention is VERY HIGH, HIGH, MEDIUM, LOW or VERY LOW. Make a comment to justify the priority.
1. Source of water is likely to be contaminated	Use of registered sources only with current grading known DWA approved source Currently disinfect water in tankers	
2. Contamination through filling mechanism	Dedicated hoses Good cleaning procedures Dedicated filling points (drafting points or upstands)	
3. Tank not cleaned out prior to use	COP outlines cleaning frequency and procedure	
4. Inadequate backflow at filling points	Use only local authority approved filling points or fill tank using air gap separation	
5.		
6.		

Transportation

Describe what could cause water to become unsafe to drink (including not enough water)	Is this under control now? If so, describe how it is being controlled.	If not, judge whether the PRIORITY for attention is VERY HIGH, HIGH, MEDIUM, LOW or VERY LOW. Make a comment to justify the priority.
7. Inadequately fitting lids, seals etc allow contamination	Checking to ensure all openings are well closed Regular maintenance	
8. Mixing/tainting with residuals in the tanker	Good SOP regarding clean between loads (COP outlines this) Dedicated drinking water only tankers Stainless steel tanks	
9. Water in tanker in the sun or delivery time too long between filling and delivery.	Ensure water is not stored in tanker for long periods of time	
10.		
11.		
12.		

Delivery

Describe what could cause water to become unsafe to drink (including not enough water)	Is this under control now? If so, describe how it is being controlled.	If not, judge whether the PRIORITY for attention is VERY HIGH, HIGH, MEDIUM, LOW or VERY LOW. Make a comment to justify the priority.
13. Disturbing debris in clients tank	Good filling technique including use of baffles or filling along the side of the tank Advise customer to leave water container for filling so tank contents can settle	
14. Mixing with water already in the tank	Noted on delivery docket as 'partial load'	
15. Tank in poor condition which allows potential for on-going contamination	Note on docket Provide info for customer such as MoH pamphlet water collection tanks	
16. Difficulties in access to allow good practice when filling	Note on docket Longer delivery hoses	
17. Dual tank which also collects rainwater which offers potential to contaminate delivered water	Note on docket Provide information for customer such as MoH pamphlet water collection tanks	
18. Backflow from tank into tanker	Collapsible hose Air gap separation when filling	

Other

Describe what could cause water to become unsafe to drink (including not enough water)	Is this under control now? If so, describe how it is being controlled.	If not, judge whether the PRIORITY for attention is VERY HIGH, HIGH, MEDIUM, LOW or VERY LOW . Make a comment to justify the priority.
19. Inexperienced drivers	Training in good practice given prior to drinking water deliveries	
20. Non-registration as a tankered water carrier	Must be registered if delivering on more than five days in any 12-month period	
21. Poor general hygiene practices by drivers	Std operating procedures re hand washing (including while 'on the road' – ie, carry water/soap or waterless cleaner), not working if ill, covering wounds etc Refer MoH COP	
22. Poor maintenance and storage of ancillary equipment (hoses, couplings etc)	Good storage practices including sterilisation, hose caps, storage away from boots, wet weather gear etc Refer MoH COP	
23. Water sampling procedure not followed	Have appropriate sampling procedure including training Refer MoH COP	
24. Sabotage	Ensure tanker is stored in an area not accessible to the public, locked tanker lids	

STEP 3: PLANNING TO MANAGE WHAT NEEDS ATTENTION

Now that you have decided what needs priority attention so the water does not become unsafe to drink, you need to think about what improvements will fix the problem. Some improvements will be a simple adjustment of something you are already doing. Some improvements will cost very little, and others could be more major.

Even for those improvements you cannot fix straight away the risk of people getting sick remains. So, you should be thinking about temporary actions for these. It might be something like issuing a boil water notice, or manually shutting off the intake.

You also need to find some sign/indicator/trigger that things are going wrong and that you need to take this temporary action.

Copy all of the events that need some attention from the previous section into the corresponding four tables in this section. Then fill in the rest of the tables.

Collection of water

<p>Copy all of the events that need some attention from the <i>Prioritising What Needs Attention</i> section.</p> <p>Note the priority for attention.</p>	<p>IMPROVEMENT SCHEDULE: How can you fix the problem?</p> <p>More detail can be recorded in the <i>Improvement Plan</i> section.</p>	<p>Until fixed, how will you know when this is actually causing unsafe drinking-water?</p> <p>More detail can be recorded in the <i>Monitoring and Inspection Plan</i> section.</p>	<p>What action will be taken if things go wrong?</p> <p>More detail can be recorded in the <i>Emergency and Incident Plan</i> section.</p>
<p>1. Source of water is likely to be contaminated</p>	<p>Investigate alternative sources that are registered well graded supplies. Get source approved by DWA as suitable.</p>	<p>Ungraded water supply, history of non-compliance, odour or dirty looking water.</p>	<p>Advise customer of water source and that water will need to be boiled if used for human consumption. Chlorination of filled tank.</p>
<p>2. Contamination through filling mechanism</p>	<p>Follow procedures in MoH COP.</p>	<p>Odour or dirty looking water.</p>	<p>Advise customer that water will need to be boiled if used for human consumption. Chlorination of filled tank.</p>
<p>3. Tank not cleaned out prior to use</p>	<p>Follow procedures and frequency in MoH COP for tank cleaning.</p>	<p>Odour or dirty looking water.</p>	<p>Advise customer that water will need to be boiled if used for human consumption. Chlorination of filled tank.</p>
<p>4. Inadequate backflow at filling points</p>	<p>Use only local authority approved filling points that have backflow prevention or fill tank using air gap separation.</p>	<p>Backflow noticed while filling, low pressure system.</p>	<p>Advise customer that water will need to be boiled if used for human consumption. Chlorination of filled tank.</p>

Transportation

<p>Copy all of the events that need some attention from the <i>Prioritising What Needs Attention</i> section. Note the priority for attention.</p>	<p>IMPROVEMENT SCHEDULE: How can you fix the problem? More detail can be recorded in the <i>Improvement Plan</i> section.</p>	<p>Until fixed, how will you know when this is actually causing unsafe drinking-water? More detail can be recorded in the <i>Monitoring and Inspection Plan</i> section.</p>	<p>What action will be taken if things go wrong? More detail can be recorded in the <i>Emergency and Incident Plan</i> section.</p>
<p>7. Inadequately fitting lids, seals etc allow contamination</p>	<p>Renewal/replacement of lids etc</p>	<p>Regular checks of lids to ensure that they are tight fitting</p>	<p>Advise customer that water may need to be boiled if used for human consumption Chlorination of filled tank</p>
<p>8. Mixing/tainting with residuals in the tanker</p>	<p>Dedicated drinking water tanks. Clean as per the MoH COP if non potable water or other liquids are transported</p>	<p>Taste and odour</p>	<p>Empty tanker and clean as per the MoH COP</p>
<p>9. Water in tanker in the sun or delivery time too long between filling and delivery</p>	<p>Ensure water is not stored in tanker for long periods of time</p>	<p>Taste and odour or water visually dirty</p>	<p>Empty old water and refill Chlorination of filled tank</p>

Delivery

<p>Copy all of the events that need some attention from the <i>Prioritising What Needs Attention</i> section. Note the priority for attention.</p>	<p>IMPROVEMENT SCHEDULE: How can you fix the problem? More detail can be recorded in the <i>Improvement Plan</i> section.</p>	<p>Until fixed, how will you know when this is actually causing unsafe drinking-water? More detail can be recorded in the <i>Monitoring and Inspection Plan</i> section.</p>	<p>What action will be taken if things go wrong? More detail can be recorded in the <i>Emergency and Incident Plan</i> section.</p>
<p>13. Disturbing debris in clients tank</p>	<p>Good filling technique. COP Advise customer to leave water container for filling so tank contents can settle. Leave MoH pamphlet</p>	<p>The water will be visibly dirty and have suspended sediments.</p>	<p>Advise customer to leave water container for filling so tank contents can settle.</p>
<p>14. Mixing with water already in the tank</p>	<p>Note on delivery docket that tanker water mixed with current water. Leave MoH pamphlet.</p>		<p>Advise customer to leave water container for filling so tank contents can settle.</p>
<p>15. Tank in poor condition which allows potential for ongoing contamination</p>	<p>Note on delivery docket about state of tank. Leave MoH pamphlet.</p>	<p>Tank in poor condition, visually inspect tank.</p>	<p>Advise customer that water may need to be boiled if used for human consumption.</p>
<p>16. Difficulties in access to allow good practice when filling</p>	<p>Note on delivery docket on difficult access. Longer filling hoses. Do not deliver until access is better.</p>	<p>Cannot safely deliver water. Individual health and safety and assessment of access by driver.</p>	<p>Do not deliver until access is better.</p>
<p>17. Dual tank which also collects rainwater which offers potential to contaminate delivered water</p>	<p>Note on delivery docket that tanker water mixed with current water and may be contaminated. Leave MoH pamphlet.</p>		<p>Advise customer that water may need to be boiled if used for human consumption</p>
<p>18. Backflow from tank into tanker</p>	<p>Collapsible hose. Air gap separation when filling.</p>		<p>Advise customer that water may need to be boiled if used for human consumption</p>

Other

<p>Copy all of the events that need some attention from the <i>Prioritising What Needs Attention</i> section. Note the priority for attention.</p>	<p>IMPROVEMENT SCHEDULE: How can you fix the problem? More detail can be recorded in the <i>Improvement Plan</i> section.</p>	<p>Until fixed, how will you know when this is actually causing unsafe drinking-water? More detail can be recorded in the <i>Monitoring and Inspection Plan</i> section.</p>	<p>What action will be taken if things go wrong? More detail can be recorded in the <i>Emergency and Incident Plan</i> section.</p>
19. Inexperienced drivers	Driver training. Ensure all drivers are familiar with the MoH COP.	Taste, odour and visually dirty water.	
20. Non-registration as a tankered water carrier	Must be registered if delivering more than five tanker loads in any one year period. Provide registration process details.	Tanker or company not registered.	Register as tankered water carrier.
21. Poor general hygiene practices by drivers	Driver training. Ensure all drivers are familiar with the MoH COP. Sickness policy.	Illness associated with water delivered from specific tanker or driver.	
22. Poor maintenance and storage of ancillary equipment (hoses, couplings etc)	Good storage practices including sterilisation, hose caps, storage away from boots, wet weather gear etc. Refer MoH COP.	Equipment noticeably dirty, taste and odour.	Don't use dirty equipment, clean equipment.
23. Water sampling procedure not followed	Have appropriate sampling procedure including training. Refer MoH COP.	Unusual water sample results.	Take additional samples, advise customer to boil water if appropriate and results received in time.
24. Sabotage	Secure trucks and ensure lids can be locked.	Visual inspection of truck before filling.	Clean tanker as per MoH COP.

IMPROVEMENT PLAN

This section helps you to think about detailed planning for the improvements that you have identified in the *Planning to Manage What Needs Attention* section.

You should focus on the improvements identified as the highest priority for attention. But it's also satisfying to complete improvements that take very little time and money, even if these are lower priority.

For each improvement, the plan should cover:

- a breakdown into significant practical steps, eg, gather quotes, obtain approval
- estimated costs and people/expertise needed
- a named person responsible for ensuring progress on the improvement
- the timeframe for the improvement.

It may be helpful to prepare a plan that organises the improvements into categories such as:

- improved operations and maintenance
- preparing documentation, such as standard operating procedures, emergency and incident plans
- investigations, such as a catchment assessment or a new source
- training for key staff or back-up people
- minor purchases
- major infrastructure purchase.

MONITORING AND INSPECTION PLAN

Monitoring and inspection of the drinking water supply is a critical part of managing what can cause the water supply to become unsafe to drink. The results of monitoring and inspection can demonstrate that parts of the supply continue to be well managed, or that something needs attention. Monitoring and inspection results can trigger temporary action when things go wrong.

Important monitoring and inspections (observations) for your supply have already been identified in:

- *Prioritising What Needs Attention* section, under the column *Is this under control now? If so, describe how it is being controlled.*
- *Planning to Manage What Needs Attention* section, under the column *Until fixed, how will you know when this is actually causing unsafe drinking-water?*

It may be helpful to prepare a plan that organises these identified monitoring and inspections into daily, weekly, monthly, and annual requirements. The plan should include:

- what you are looking for (eg, observations like stock access, or monitoring results)
- the trigger for immediate action
- what immediate action you will take, including who needs to know and how urgently
- a place for a tick/signature to say the monitoring/inspection has been done.

It is important to keep records of monitoring and inspection results and any actions that have been taken in response to the results. Periodically, someone should look over the results for signs of anything changing that relates to the water to become unsafe to drink, eg, a gradual increase over the months or years in a chemical contaminant like nitrate, or a seasonal occurrence of algae.

EMERGENCY AND INCIDENT PLANS

You have identified some important public health risks to your water supply. You know that addressing some of these risks will take some time, and in the *Planning to Manage What Needs Attention* section you have worked out early warning signs to alert you to take some temporary action in the meantime.

This section helps you to think about detailed planning of these temporary actions.

Incident plans bring the water supply back under control before it causes a major public health problem. These plans should be used when the early warning signs of routine monitoring and inspection alert you.

Emergency plans help you to respond when the water supply has gone seriously out of control. These typically need to be used with little to no warning. Examples include major microbiological or chemical contamination as a result of acts of nature such as earthquakes, floods, cyclones, volcanic activity.

Both levels of response plans require prompt action. This requires pre-arranging, so that everyone involved is aware of the plan and their roles.

Emergency plan responses often require rapid decisions to be made without a complete understanding of the situation. Someone needs to be responsible for making these decisions.