



THE BANGA PINOY

A DESIGN AND CONSTRUCTION MANUAL
FOR WIRE-REINFORCED FERROCEMENT JARS

THE BANGA PINOY

A DESIGN AND CONSTRUCTION MANUAL FOR WIRE-REINFORCED FERROCEMENT JARS

Jose Carmelo Gendrano
Christopher Hillbruner

with
Michelle Neukirchen

Illustrations by Fred Zinn



Finalized through a participatory community-based training
in Barangay Saloy, Calinan District, Davao City, Philippines July 27–August 1, 2005
in partnership with CRS/Philippines and the Josefa Segovia Foundation

APRIL 2006

TABLE OF CONTENTS

LIST OF ILLUSTRATIONS	III
PHOTOGRAPH AND ILLUSTRATION CREDITS	IV
INTRODUCTION	1
PART A - GENERAL INSTRUCTIONS FOR CONSTRUCTING A WIRE-REINFORCED JAR	5
I. Determining Tank Size	5
II. Determining Tank Shape	5
III. The Form	5
Tools and Materials	5
Vertical Pieces	6
Horizontal Pieces	7
Constructing the Form.....	9
IV. Constructing the Tank - Day 1	12
Tools and Materials	12
Building the Tank Base	13
Starting the Tank	17
V. Constructing the Tank - Day 2	22
Attaching the Vertical Wire Supports.....	22
Horizontal Wire Reinforcement	24
Building the lid.....	28
VI. Constructing the Tank - Day 3	30
Finishing the Tank	30
VII. Building Larger Tanks	32
PART B - CONSTRUCTING A 5,000 LITER WIRE-REINFORCED JAR	35
I. Determining Tank Size	35
II. Determining Tank Shape	35
III. Building the Form	36
Tools and Materials	36
Vertical Pieces	36
Horizontal Pieces	37

IV. Constructing the Tank - Day 1	38
Tools and Materials	38
Building the Tank Base	38
Starting the Tank	40
V. Constructing the Tank - Day 2	43
Vertical Wire Supports	43
Horizontal Wire Reinforcement	45
Building the lid.....	47
VI. Constructing the Tank - Day 3	48
Finishing the Tank	48
APPENDICES	51
Appendix A - Tank Materials Cost Comparison	51
Appendix B - Determining Tank Shape	52
Determining Tank Shape	52
Determining Tank Shape II	53
Appendix C - Calculating Horizontal Wire Spacing.....	58
Appendix D - Sample Designs.....	63
3,000 Liter Wire-Reinforced Jar.....	64
5,000 Liter Wire-Reinforced Jar.....	66
7,500 Liter Wire-Reinforced Jar.....	68
10,000 Liter Wire-Reinforced Jar.....	70
20,000 Liter Wire-Reinforced Jar.....	72
Appendix E - Drawing Water Directly from the Tank.....	74
A Raised Foundation	74
Other Options	75
Appendix F - CD-ROM Notes	76
Workbook 1: Tank volume estimator	76
Workbook 2: Form and Tank material estimator	76
Appendix G - Further Resources	77

LIST OF ILLUSTRATIONS

Figs. 1-3: Ferrocement water tank, Ferrocement house, and Ferrocement boat	1
<i>Fig. 1 Credit: Centre for Technology and Development, New Delhi</i>	
<i>Fig. 2 Credit: Peter Epperson, Pacific Gunite</i>	
<i>Fig. 3 Credit: J.J. Lambot, 1848</i>	
Figs. 4-5: Cylindrical ferrocement tanks	2
Figs. 6-9: Construction of a Thai Jar.....	2
<i>Figs. 4-9 Credit: Development Technology Unit, University of Warwick</i>	
Figs. 10-11: The Sri Lankan Pumpkin Tank	3
<i>Figs. 10-11 Credit: T. Ariyananda</i>	
Fig. 12: The Wire-Reinforced Jar - a 30,000 liter tank in Camotes, Cebu, Philippines.....	3
<i>Fig. 12 Credit: Kristopher Dodge</i>	
Fig. 13: Waist diameter	6
Fig. 14: Bending rebar for the tank form.....	7
Fig. 15: Bending the horizontal hoops.....	8
Fig. 16: Marking welding points on form.....	8
Fig. 17: Rebar form.....	9
Figs. 18-19: Top view of form (with cutting location marked), and Cutting the form	10
Fig. 20: Adding optional vertical supports.....	10
Fig. 21: Form pieces covered with a) wire, and b) newspaper.....	11
Fig. 22: The completed form.....	11
Fig. 23a: Constructing the base, Step 1 (front and section view)	13
Figs. 23b: Constructing the base, Step 2 (front and section view)	14
Fig. 23c: Constructing the Base, Step 3 (front and section view).....	15
Fig. 24: The completed base (front and section view)	16
Fig. 25: Starting the tank.....	17
Fig. 26: The first layer	19
Figs. 27-28: Adding rebar to plumbing fixtures and Plumbing fixture placement.....	20
Fig. 29: The rim form.....	20
Fig. 30: Jar after first layer of mortar with pipe fittings and rim form.....	21
Fig. 31: Second coat of cement mortar	22
Fig. 32: Roof wire reinforcement placement	23
Fig. 33: Top view - correct vertical wire reinforcement placement.....	23
Figs. 34a-d: Top view - Adding vertical wire reinforcement	23
Fig. 35: Jar after completion of vertical wire reinforcement	24
Fig. 36: Example of horizontal wire spacing for a 5,000 L tank	25
Fig. 37: Jar after completion of horizontal wire wrapping	26
Fig. 38: Applying the final coat of mortar.....	27
Figs. 39-40: The completed rim	27
Figs. 41a-e: Constructing the lid.....	28

Fig. 42: Removing the form.....	31
Fig. 43: Applying a final layer of mortar inside the tank	31
Fig. 44: Wall thickness of a 30 m ³ wire-reinforced ferrocement jar	32
Fig. 45: Tank with roof cap	33
Fig. 46: Shape of a 5,000 liter tank.....	35
Figs. 47-48: Completed form pieces.....	37
Fig. 49-50: Excavating the base and Adding gravel.....	39
Fig. 51: Adding base reinforcement.....	39
Figs. 52-53: Pouring cement and The completed base.....	40
Figs. 54-55: Assembling the form.....	40
Fig. 56: The completed form.....	41
Fig. 57: Plastering the first layer	42
Figs. 58-59: Attaching pipe fittings.....	42
Fig. 60: Plastering the second layer	43
Figs. 61-62: Wire placement in relation to the rim, and Connecting the wire to the tank base	44
Fig. 63: Completed vertical wire reinforcement	44
Fig. 64: Wire wrapping for a 5,000 liter tank (h = 1.9 m)	45
Fig. 65: Marking horizontal wire placement.....	45
Fig. 66: Horizontal wire reinforcement	46
Fig. 67: Applying the final layer.....	46
Fig. 68: Forming the rim	47
Figs. 69a-d: Constructing the lid.....	47
Fig. 70: Removing the form.....	48
Fig. 71: Plastering the inside of the tank.....	48
Fig. 72: Completed tank.....	49
Fig. 73: Completed Tank with lid, valve box and optional splash-pad for erosion prevention	49
Fig. 74: Cylinder	52
Fig. 75: Tank shape, top - Step 1	54
Fig. 76: Tank shape, top - Step 2.....	54
Fig. 77: Tank shape, top - Step 3.....	55
Fig. 78: Tank shape, bottom -Step 1	55
Fig. 79: Tank shape, bottom -Step 2	56
Fig. 80: Tank shape, bottom - Step 3	56
Fig. 81: Final tank shape.....	57
Fig. 82: The water pressure triangle.....	58
Fig. 83: Determining horizontal wire wrapping density.....	59
Fig. 84: Building a raised foundation	75
Fig. 85: Sump hole.....	75

Remaining Photos and Illustrations Credit: F. Zinn and C. Hillbruner

NOTES

INTRODUCTION

What is ferrocement?

Ferrocement consists of metal reinforcement sandwiched between thin layers of cement mortar. Different types of reinforcement are used, including wire, wire mesh and steel bar. Aside from its strength and flexibility, it is a useful technology in the developing world for a variety of reasons. The required materials are widely available; the skills needed for ferrocement construction can be easily acquired; heavy machinery is not required; ferrocement structures are easy to repair; and, because ferrocement is labor-intensive, it is relatively inexpensive in developing countries (Mullins, 1988). Ferrocement tank life can exceed 50 years if proper materials are used and tanks are constructed carefully (Watt, 1978).



Figs. 1-3: Ferrocement water tank, Ferrocement house, and Ferrocement boat

Ferrocement can be used to construct a wide range of structures including boats, houses, and grain silos. One particularly popular use for ferrocement is water tank construction. Ferrocement resists cracking very well and, due to its thinness, uses very little cement. This results in a lighter, less expensive tank than traditional poured concrete tanks, while still being comparably strong (Turner, 2000). Ferrocement tanks are also more durable, more hygienic, need less upkeep and are often cheaper than metal water tanks (Watt, 1978 and Mullins, 1988).

Are there different types of ferrocement water tanks?

Yes, there are a variety of different designs. The oldest and most common design is a cylindrical tank. Tanks with this shape are constructed by using a removable form, constructed of corrugated galvanized iron (GI) sheets. Reinforcement is provided by a combination of wire mesh and heavy steel wire (2.5 mm). A concrete floor is poured and the framework is plastered with a number of thin layers of cement mortar. The tank is completed with the construction of a flat or domed lid (Watt, 1978). Cylindrical tanks can also be constructed without a form. In this case, a framework of steel bar and wire mesh is constructed and then plastered with mortar. Cylindrical tanks are also referred to as *singly curved* tanks because while they are round horizontally, they are straight along the vertical axis (Turner, 2000).

Other ferrocement tank styles include the “Thai Jar”, the “Sri Lankan Pumpkin Tank”, and the “Wire-Reinforced Jar.” All three of these designs are referred to as *doubly curved* tanks, because they are rounded both horizontally and vertically (Turner, 2000). Research has shown that doubly curved tanks have a number of benefits. First, they are stronger than singly curved tanks. Second, tanks with doubly curved walls utilize less material and therefore can be less expensive. Finally, doubly curved walls help to prevent cracking, especially at the bottom of the tank where the walls meet the base (Turner, 2000).



Figs. 4–5: Cylindrical ferrocement tanks

The Thai Jar design was developed in the 1980s (see figures 6-9). This design is typically used for smaller, individual household tanks ranging in size from 400 L to 3,000 L. Rather than using a metal mold or form, the tank is constructed around a specially sewn cloth or plastic bag that has been filled with sand or rice husks. Layers of cement are plastered onto this form. Once the cement has dried, the sand is removed from the sack, the sack is removed from the tank and cement slurry is applied to the inside (Rees and Whitehead, 2000). Because Thai Jar tanks are usually small, they don't always need wire or mesh reinforcement between the layers of mortar. Technically, tanks without such reinforcement are not ferrocement. This design is often the simplest and most cost-effective option for very small tanks (less than 0.8 m³).

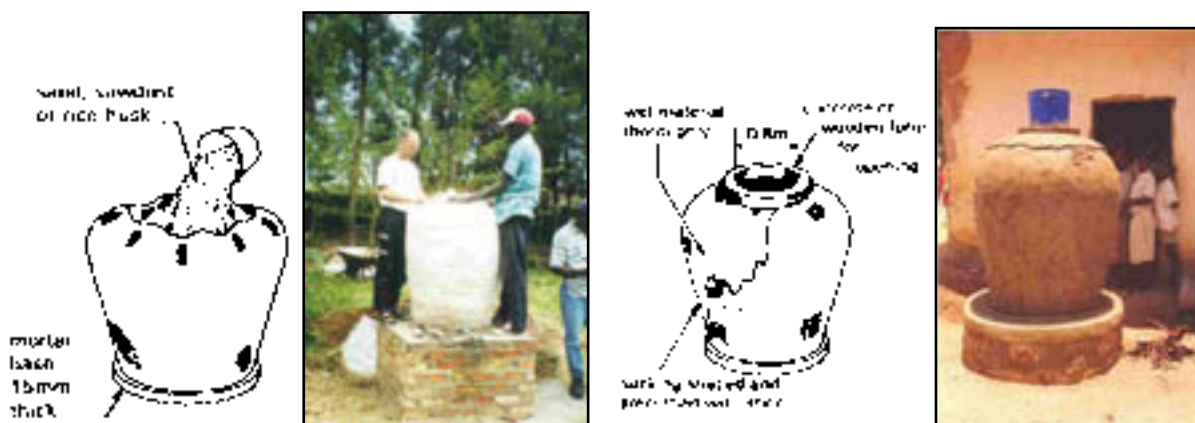

Figs. 6–9: Construction of a Thai Jar

The Pumpkin Tank was developed in Sri Lanka during the mid-1990s as part of a rainwater catchment promotion program (see figures 10-11). Its design and construction techniques are in many ways similar to the cylindrical tank. However, unlike cylindrical tanks, it has doubly curved walls and is constructed using a removable steel bar framework. Because the form is removed, it can be reused for multiple tanks, thus lowering the overall cost of tank construction (Ariyananda, 1999 and 2004).

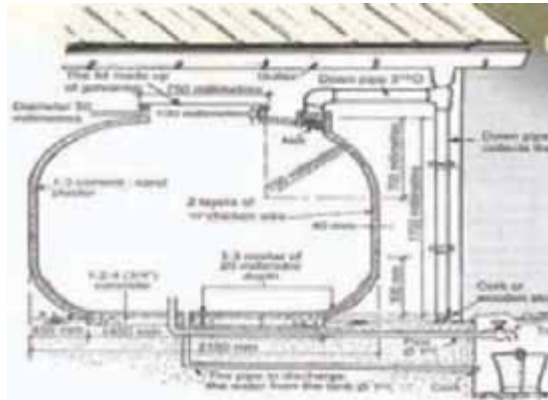

Figs. 10–11: The Sri Lankan Pumpkin Tank

Finally, there is the Banga Pinoy or Wire-Reinforced Jar design (see figure 12), developed in Philippines, also in the mid-1990s, by Jose Carmelo Gendrano. Like the Pumpkin Tank, it utilizes curved walls and a removable and reusable steel bar form. However, it is different from other tank designs because it uses thin wire wrappings for reinforcement and not wire mesh, steel bar or heavy steel wire. It also uses less cement than other doubly curved tank designs. These differences can result in significant cost savings. In addition, while the Pumpkin Tank does use a removable form, it must be rebuilt, piece-by-piece, each time a tank is constructed. Not only is this time consuming, but a proper alignment is also more difficult to achieve. The Wire-Reinforced Jar design uses a welded form that has been cut into manageable pieces. Form setup is faster and a more consistent tank shape can be easily achieved.

The Wire-Reinforced Jar design can be constructed in a wide range of tank sizes. In the Philippines, this method has been used for tanks as large as 40,000 L. Therefore, it can be used for a variety of applications, from single-family rainwater catchment systems to large, piped water system reservoirs.



Fig. 12: The Wire-Reinforced Jar — a 30,000 liter tank in Camotes, Cebu, Philippines

Who Can Use This Manual?

This manual is designed to aid in the construction of a wire-reinforced, jar-shaped ferrocement water tank. This method is well-suited for tanks with a volume of 600 L or more. It was written for people without extensive engineering or construction experience. Therefore, certain tasks, such as determining the shape of the tank, have been simplified. For those with more experience, or more interest, the full design processes are explained in the appendices.

The manual will be most effective when used as part of a ferrocement tank construction training or as a reference by someone who has built a tank before and needs a refresher. If you have never built a tank before, this book can still be a helpful resource. However, you may want to get expert advice from someone with more experience.

How Can This Manual Be Used?

The manual includes specific guidance on constructing tanks up to 20,000 L. Tanks larger than 20,000 L can be built using similar methods. However, a few adjustments would need to be made during design and construction (See Section A.VII - Building Larger Tanks). Part A of this manual offers general guidance for constructing a jar-shaped, wire-reinforced ferrocement tank. Part B details the specific steps and calculations for building a 5,000 L jar.

Ferrocement Tank Resources:

<p>Philippine Center for Water and Sanitation</p> <p>P3 Minnesota Mansion, 267 Ermin Garcia Street, Cubao, Quezon City, Philippines 1109 Manila Philippines</p> <p>Phone: +632 912-0531 +632 421-9470 Fax: +632 911-5783</p> <p>E-mail: itnphil@compass.com.ph</p> <p>Website: www.itnphil.org.ph</p>	<p>Catholic Relief Services (CRS)</p> <p>Megaroopan Jeganathan</p> <p>Program Quality and Support Dept. 209 W. Fayette Street Baltimore, MD 21201 USA</p> <p>Phone: 410-625-2220</p> <p>Website: www.crs.org</p>
<p>Jose Carmelo Gendrano</p> <p>E-mail: bojig@yahoo.com</p>	<p>Christopher Hillbruner</p> <p>E-mail: hillbrun@hotmail.com</p>

PART A

GENERAL INSTRUCTIONS FOR CONSTRUCTING A WIRE-REINFORCED JAR

This section will provide a general description of how a Wire-Reinforced Ferrocement Jar is constructed. The tools and techniques described below can be used for any size tank. Please refer to Section VII - Building Larger Tanks, for additional guidance on constructing tanks larger than 20,000 L. Following the general instructions, Part B will detail the construction process for a 5,000 L (5m³) tank.

I. Determining Tank Size

Choosing a size for the water tank depends on a number of factors. These include: the purpose of the tank (rainwater catchment or piped system); the number of people using the tank; and the volume of water available for collection (i.e., spring flow, rainfall, or pump output). Many issues are involved in determining tank size and a comprehensive explanation of how to determine tank size is beyond the scope of this manual. However, the CD-ROM included with this manual features spreadsheets for estimating tank size, both for rainwater catchment and piped systems. For more detailed information on designing water systems and estimating reservoir volume please refer to Appendix G - Further Resources.

II. Determining Tank Shape

After determining the tank size based on storage volume needed, the next step is to design the tanks' shape. To calculate the dimensions of a specific tank shape, please refer to Appendix B - Determining Tank Shape. This section details the process and mathematical steps to follow when designing a tank from scratch. Alternatively, refer to Appendix D, which contains sample designs in a range of sizes.

III. The Form

In order to support the ferrocement while building the tank, construct a form out of reinforcing bar and wire mesh. This form will be removed once the tank has dried, and can be used again in constructing future tanks.

Tools and Materials

The following tools and materials are needed to construct the form:

Materials

reinforcing bar (rebar)	paint
½" wire mesh	newspaper
#18 (1.4 mm) steel wire	cassava or laundry starch
welding rod	

Tools

hacksaw	nail and string
tape measure	wire cutters
hammer	welding machine
pieces of scrap lumber	paintbrushes
chalk	

Forms for jar-shaped tanks can be built from either 6 mm, 8 mm or 10 mm steel bar. The smaller-size bar is cheaper and easier to bend into shape. Forms made from the smaller bar are also more flexible and therefore are more easily removed at the completion of tank construction. But these forms are less durable than those using larger sizes of rebar and also more quickly bend out of shape (10 mm forms will be stronger, but they are more expensive and more difficult to build). Generally, forms should adhere to the following guidelines:

Tank Size (L)	Steel Rebar Thickness (mm)
2,000–5,000	6
6,000–15,000	8
15,000 and larger	10

Vertical Pieces

Begin by cutting and shaping the vertical rebar pieces.

1. Determine the tank's circumference at its widest point, the waist. Based on the tank design and chosen height, the diameter (ϕ) can be determined. The waist circumference of the tank (C) can be found by multiplying the diameter (ϕ) by π (3.14), as in example 1.

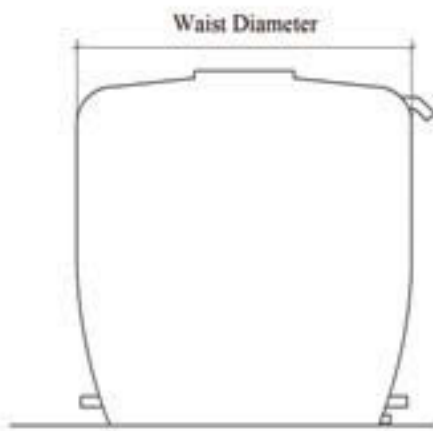

Example 1:

$$\phi = 2 \text{ m}$$

$$\pi = 3.14$$

$$C = \phi \times \pi$$

$$C = 2 \times \pi = 6.28$$

Fig. 13: Waist diameter

2. One vertical piece is needed every 20 cm or less along the waist circumference of the tank. Later in the construction process, the form will be cut into sections, and additional vertical pieces will be needed. To determine the number of vertical pieces needed, multiply the circumference by 6.66 (see example 2).

Example 2:

$$\text{Circumference } (C) = 6.28 \text{ m}$$

$$\# \text{ of verticals} = 6.66C = 6.66 \times 6.28 = 41.83 = 42$$

Multiplying by a factor of 6.66 is a simplification of the following equations.

$$\frac{C}{0.2} = 5C = \text{number of vertical pieces needed, assuming 20 cm spacing}$$

$$\frac{C}{0.6} = 1.66C = \text{number of extra pieces needed assuming the form is cut into 60 cm sections. (60 cm is used assuming a manhole diameter of at least 65 cm.)}$$

$$5C + 1.66C = 6.66C$$

- Cut a piece of steel bar, of the proper length, for each vertical piece needed. Draw the shape of the vertical pieces on a flat concrete or wooden surface. (To determine the length and shape of the vertical pieces refer to the sample designs in Appendix D or the form design instructions in Appendix B). Then, using a hammer and the pieces of scrap lumber, bend the steel bar into the proper shape (see figure 14).

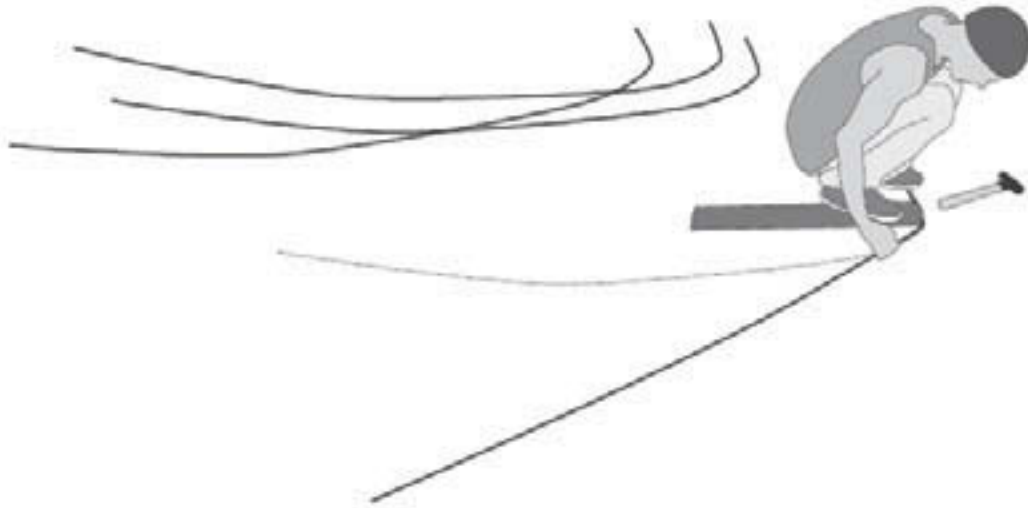

Fig. 14: Bending rebar for the tank form

Horizontal Pieces

- One horizontal hoop is needed for every 37.5 cm or less of height. Example 3 shows how to determine the number of horizontal hoops and spacing necessary for each.

Example 3:

Height (h) = 2.1 m

$$\# \text{ of horizontal hoops} = N_{\text{hoops}} = \left(\frac{h}{0.375} \right) + 1 = \left(\frac{2.1}{0.375} \right) + 1 = 6.6 \approx 7$$

$$\text{Location of Hoops} = \frac{h}{(N_{\text{hoops}} - 1)} = \frac{2.1}{6} = 0.35\text{m}$$

Starting from the base, the tank in this example would need 7 horizontal hoops, one every 0.35m along the vertical axis

Note: The equation accounts for one additional hoop that is needed at the top of the tank.

2. The horizontal pieces will be ring shaped and most of them will equal the circumference (C) in length. Please note that because the form curves, the steel bar hoops at the bottom and the top will be slightly smaller than those in the middle.
3. Use a nail, string and chalk to draw circular patterns for the horizontal hoops on a flat concrete or wooden surface. Then bend pieces of steel bar into hoops of the proper size using the same method used for the vertical pieces (figure 15).

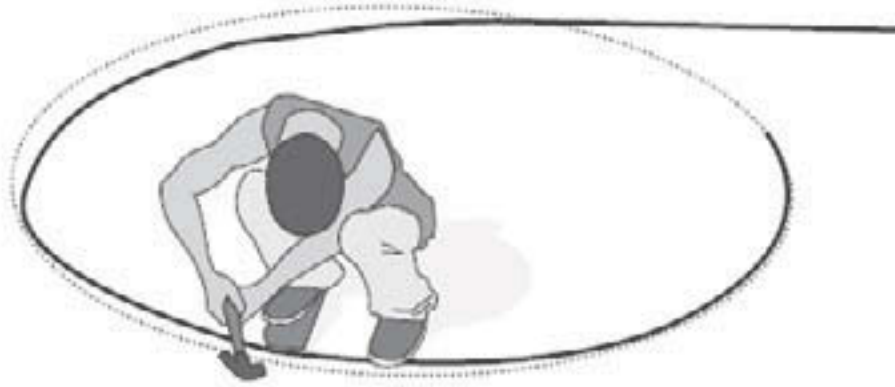

Fig. 15: Bending the horizontal hoops

4. Once all of the pieces are cut and bent, take the largest hoop and mark it every 20 cm (or less, depending on the spacing of your vertical pieces). This will show you where the vertical pieces will be welded. Mark an X on the ground and lay the hoops on the ground, centered on this mark. Then, using a length of rebar, the center point and the markings on the largest hoop, mark the welding locations on the remaining hoops (figure 16).

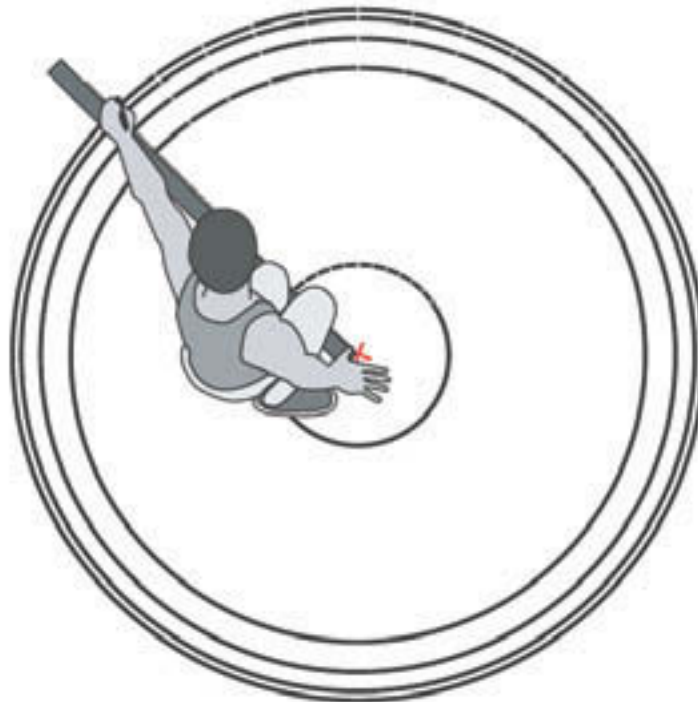

Fig. 16: Marking welding points on form

Constructing the Form

1. Take the vertical and horizontal pieces to a welding shop and have them welded together, following the markings you made on the horizontal hoops (see figure 17). Remember, the horizontal hoops should be on the *inside*, and the vertical pieces on the outside. Then, take the remaining vertical pieces and weld one next to every third vertical, creating a series of “double verticals.”

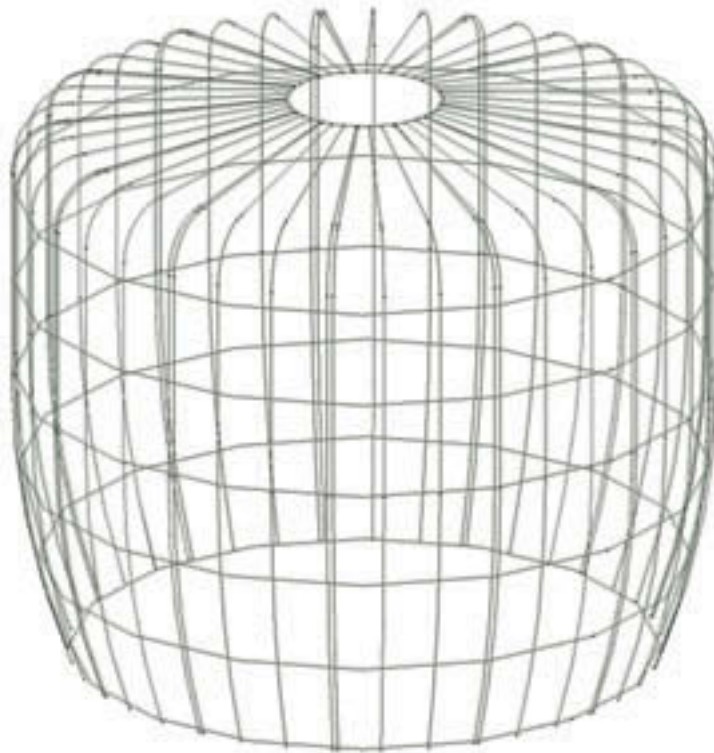
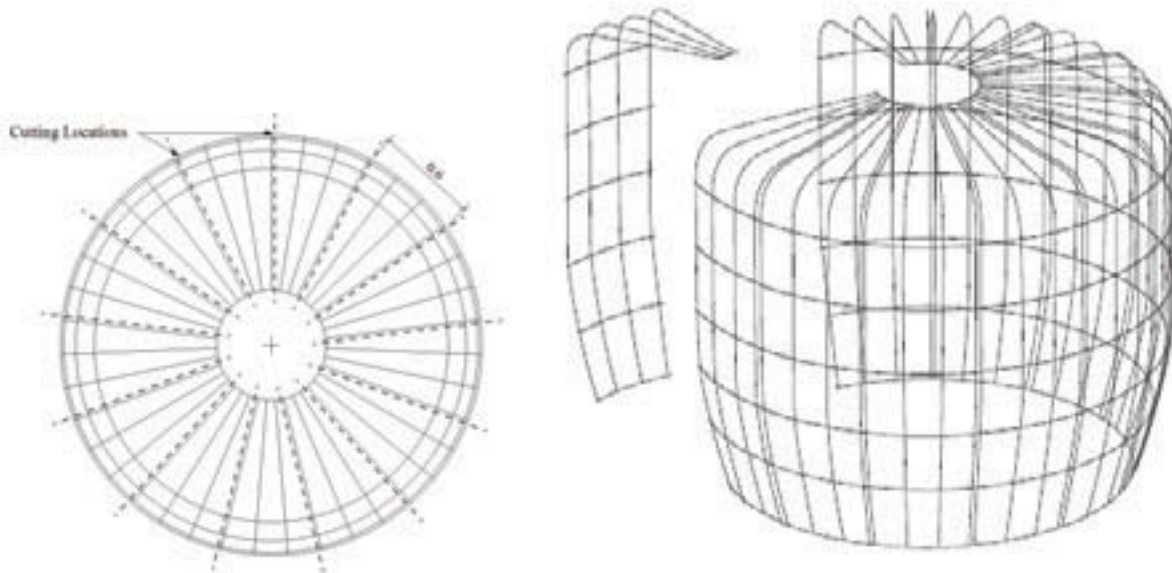

Fig. 17: Rebar form



Figs. 18–19: Top view of form (with cutting location marked), and Cutting the form

2. Separate the form into pieces by cutting between each of the double verticals (figures 18-19). (Remember: Each of these pieces should be approximately 60 cm wide and small enough to fit through the finished manhole of the tank. If the manhole will be smaller than 60 cm, the placement of the extra verticals may need to be modified.) Once the form has been cut apart, vertical supports can be added by welding additional pieces of rebar to the form sections (figure 20). These help the form maintain its shape during construction. However, adding these vertical supports is expensive and can make it more difficult to transport the form pieces. An alternative option is to add wooden posts at the construction site to support the roof (as in figure 22).

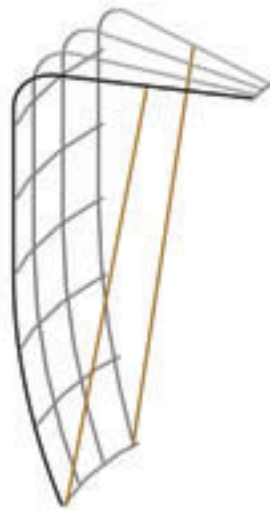

Fig. 20: Adding optional vertical supports

3. Finally, cover each piece with ½” wire mesh. Be sure the mesh is stretched tightly across the frame and tie it to the form with wire (figure 21a). Paint the form to prevent corrosion.

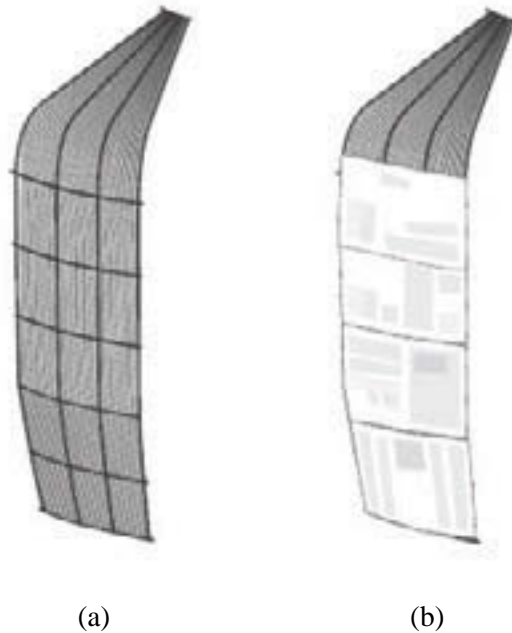

Fig. 21: Form pieces covered with a) wire, and b) newspaper

4. The form can be transported in pieces. Then, at the worksite, cover the wire mesh with three layers of newspaper. The first two layers should be dipped in a mixture of one part cassava starch (or flour) and eight parts water (figure 21b). The final layer should not be dipped in the starch mixture, just laid over the wet newspaper. This will prevent the paper from sticking to the cement and make the form pieces easier to remove. Let the paper dry completely. Alternatively, the form pieces can be covered with woven plastic (e.g., rice or cement sacks).
5. Before construction, assemble the pieces by climbing inside and tying the pieces together with #18 steel wire (figure 22).

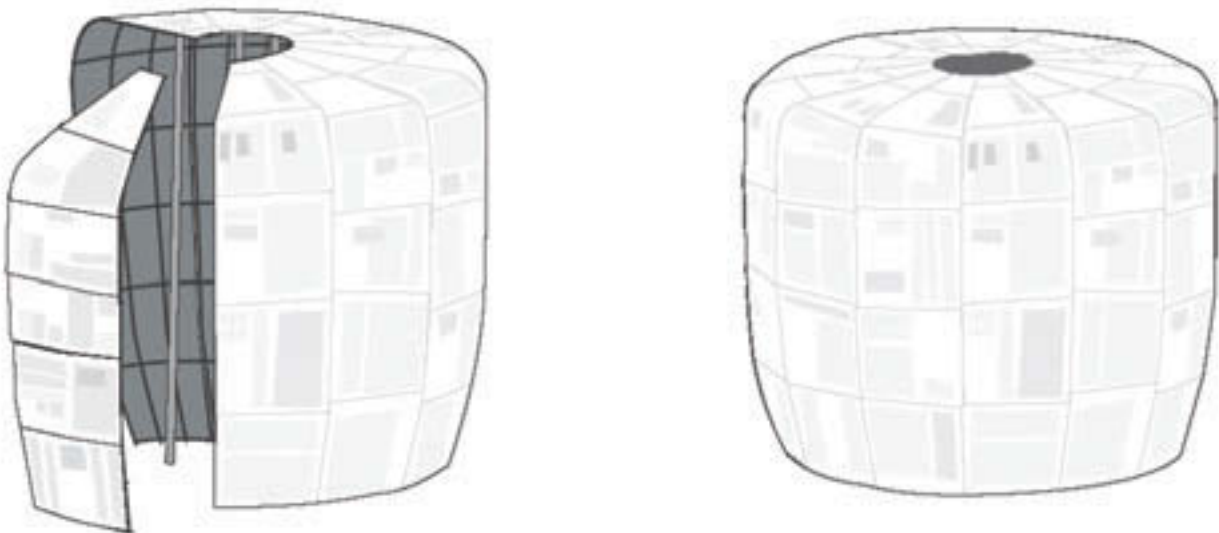

Fig. 22: The completed form

IV. Constructing the Tank - Day 1

Tools and Materials

Materials

screened, non-calcareous sand (m³)
gravel (m³)
Portland cement (40 kg bags)
waterproofing compound (1 kg bags)
#18 (1.4 mm) steel wire (kg)
8 mm rebar (6 m)
pipe fittings of appropriate size (1 inlet, 1 outlet, 1 overflow, 1 cleanout)
flat galvanized iron sheet (0.8 m x 2 m pieces)
tank form

*Note: If any materials cannot be found, please consult with an experienced individual before substituting.
Most materials cannot be interchanged.*

Tools

wire cutters
hacksaw
shovels
buckets
tin snips
pliers
measuring box (for measuring sand and gravel, and mixing cement)
spirit level (carpenter level)
tape measure
screen or sand sieve
masonry trowels and floats
extra cement sacks or newspapers

Choosing Good Sand

Sand for ferrocement should be non-calcareous, meaning that it does not come from limestone or broken-down coral. These types of sand tend to cause a lot of cracking. Generally, avoiding calcareous sand means using river sand and not beach sand.

If calcareous sand is the only option, use a richer mix of cement for the tank, 1:2 cement:sand for the first layer and 1:2.5 cement:sand for subsequent layers. To see if a usable mix has been achieved, apply a thin coat of mortar and let it dry. If it only has a few cracks and does not crack further upon the application of a second coat, the mix should be fine. Additionally, a pozzolan cement can be used for the final inner layer of mortar, or paint the inside with natural or acrylic latex to further prevent cracking and leaking.

All sand, regardless of its source, should have good size distribution (i.e., a range of fine to coarse sand). The gradation in sand size will minimize the spaces between sand particles and result in a need for less cement. However, it is important not to have any gravel in the sand mixture. Therefore, sieve the sand before using.

For more information on mixing cement, see page 16.

River Sand - To determine whether river sand needs washing, use one of the following field tests:

1. “Rub a moist handful between your palms. Suitable sand will leave hands only slightly dirty.” (Hasse, 22)

2. “Fill a clear glass container 100 mm high with sand. Then fill with water. Shake the glass vigorously, place it on level ground and let it sit undisturbed for 1 hour. The sand settles immediately and any silt and clay settle as a dense layer on top. This layer is a different color than the sand, often darker, and should not be more than 6% of the entire thickness of the sand. If 100 mm of sand was used, a 6 mm upper layer is acceptable, but if it is more, the sand should be cleaned.” (Hasse, 22)

Calcareous (Beach) Sand — All beach sand should be washed thoroughly.

Building the Tank Base

1. Make sure the area is clean, level and solid. Ensuring a solid foundation is a key factor in building a successful tank. If the site is very soft or swampy, additional work will need to be done in order to ensure a strong foundation (Usually a “raft” of boulders is tamped 60 cm deep into the ground).
2. The diameter of the base should be 3–5 cm larger than the diameter of the bottom of the form. Mark out the location of the base with rebar stakes every 10–15 cm. Using the ring of stakes as a guide, dig a circular hole, 0.05 m (5 cm) deep (figure 23a).

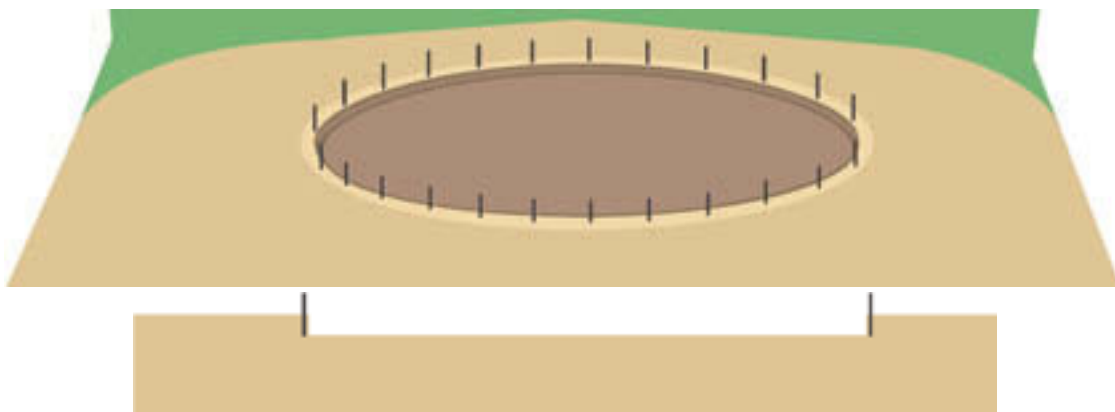
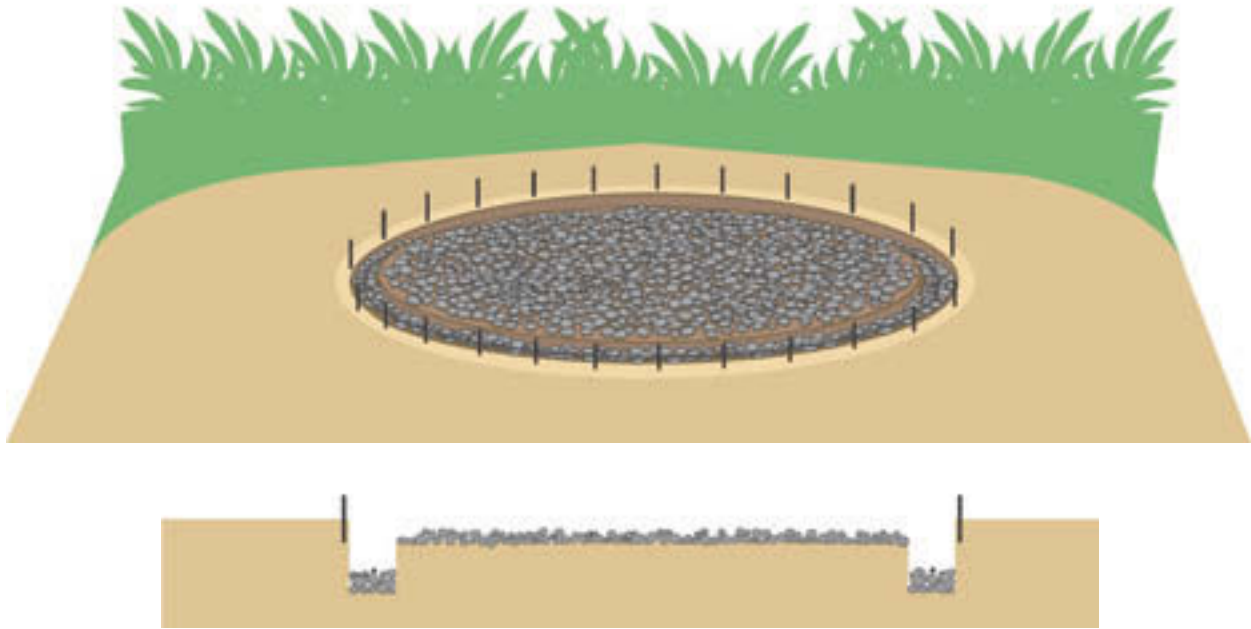

Fig. 23a: Constructing the base, Step 1 (front and section view)

3. Around the inner edge of this hole, dig a trench 0.1 m (10 cm) wide and 0.1 m (10 cm) deep. Line the bottom of the hole with large gravel, tamping down the stones so that they are anchored in the soil (figure 23b). This outer circular trench is important because it provides additional support for the tank. Without it, the outer edge of the base might experience fatigue cracking or failure.



Figs. 23b: Constructing the base, Step 2 (front and section view)

4. To strengthen the base, form a hoop out of rebar that is slightly smaller than the foundation. Mix a batch of concrete (1:2:4 cement:sand:gravel) and fill the outer trench halfway. Place the rebar hoop in the concrete and fill the trench the rest of the way.
5. Next, lay wire reinforcement across the base every 0.1–0.15 m. Then, add a second layer of wires, again every 0.1–0.15 m. The wires in this second layer should be placed perpendicular to the wires in the first layer, creating a mesh. The higher the tank, the denser the wire reinforcement needs to be. Use 0.1 m spacing for a tank height of 2.1 m. **Be sure to leave 0.15 m (15 cm) of excess wire hanging off on both sides** (to be used later when attaching vertical reinforcement wires). See figure 23c for demonstration of wire placement.
6. Once the reinforcement is in place, line the foundation with strips of sheet metal 0.05 m high, Mix a batch of concrete (1:3:5 cement:sand:gravel) with waterproofing compound and pour the concrete onto the base. Make sure the excess wires are not covered by concrete. Let the base cure overnight. The next day, remove the rebar stakes, the rebar hoop and the strips of sheet metal. See figure 24 for image of completed tank base.

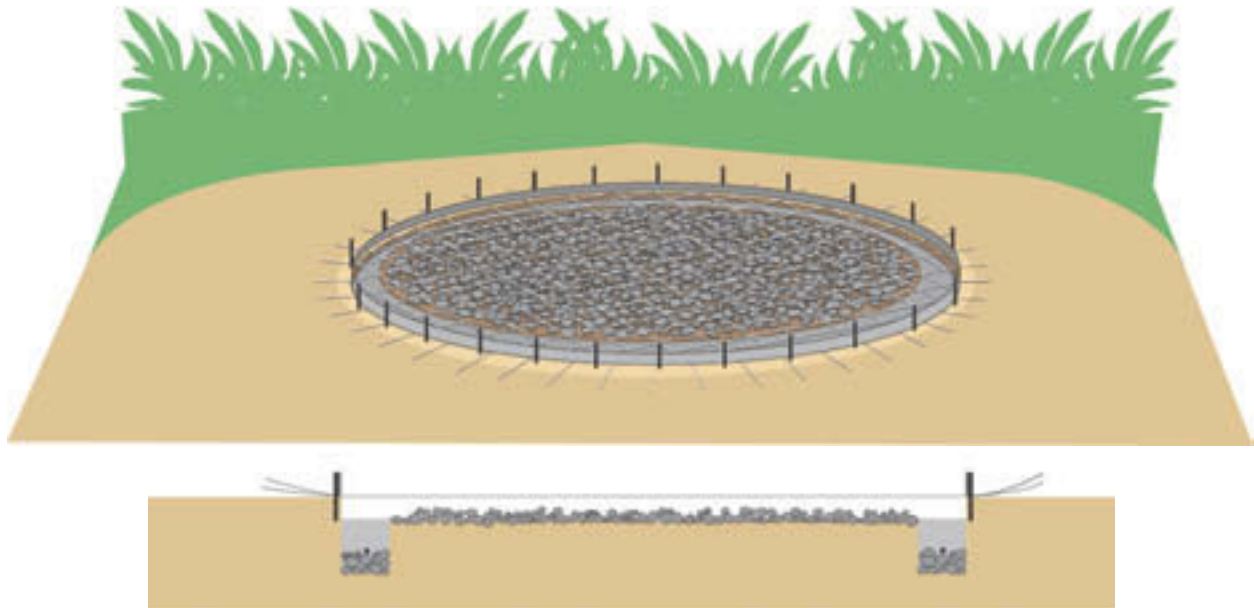

Fig. 23c: Constructing the Base, Step 3 (front and section view)

Mixing Cement

Mixing cement mortar properly is a crucial step in building a ferrocement tank. Use the following guidelines to ensure proper mixing.

1. Mix on a clean, smooth surface that is large enough for the quantity of cement you are mixing. Galvanized iron sheets or mixing boxes are best.
2. Tools should all be clean and have no mortar from previous mixing on them.
3. All materials should be ready before any mixing begins.
4. Use buckets or boxes to measure cement and sand, shovels are too inaccurate. Cement:sand ratios vary by process step. Pay particular attention to the proper ratio while building the tank.
5. Don't forget to add waterproofing compound (e.g., Sahara) if indicated.

*Note: Do **not** add too much water! This significantly weakens the cement. Just enough water should be added to make the mix workable. The cement should spread easily, but not fall off the form while plastering. The ideal ratio is approximately 26.5 liters of water per 40 kg bag of Portland cement.*

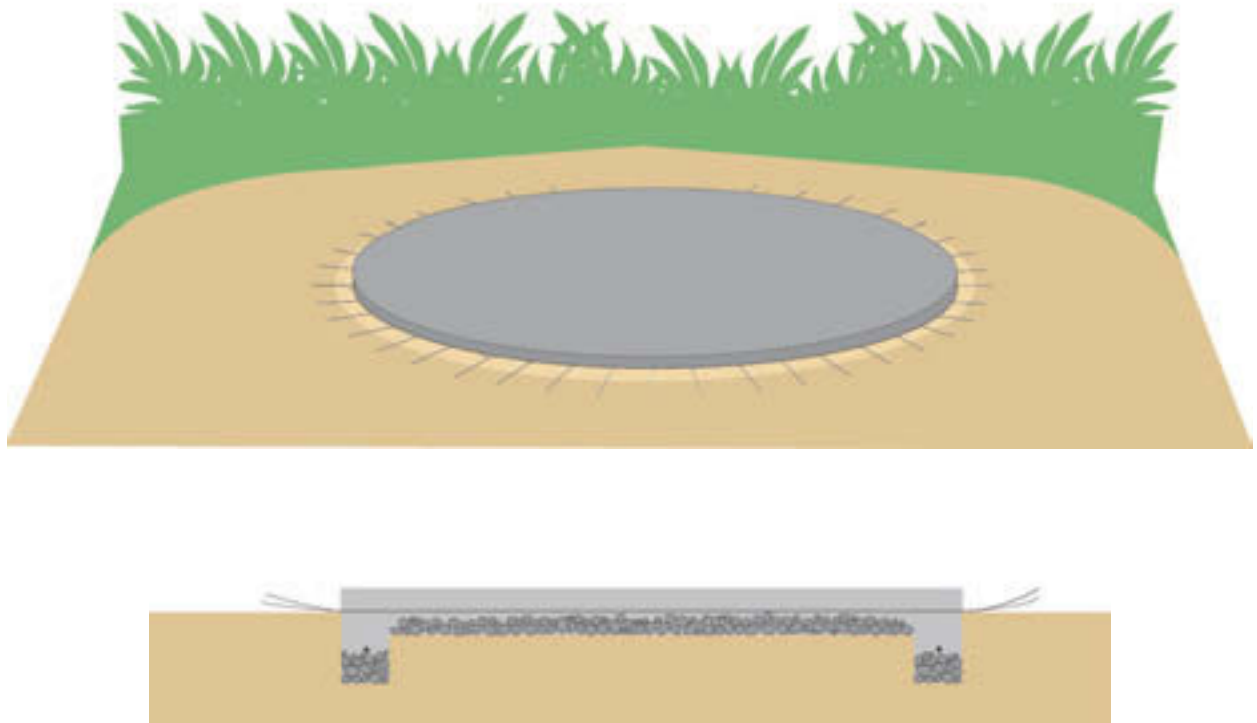

Fig. 24: The completed base (front and section view)

Starting the Tank

1. When the base is dry, tie the steel bar form together (figure 25). Putting the form together on the base or another flat surface is crucial to achieving proper form alignment. Be sure that the wires sticking out from the base are not caught under the frame. Place bags of rocks or sand against the inner wall of the form. This will prevent the form from moving while plastering the first layers of mortar. Wrap the form horizontally in #18 steel wire about every 10 cm. This will help hold the form together and give the first layer of mortar something to “grab” onto.

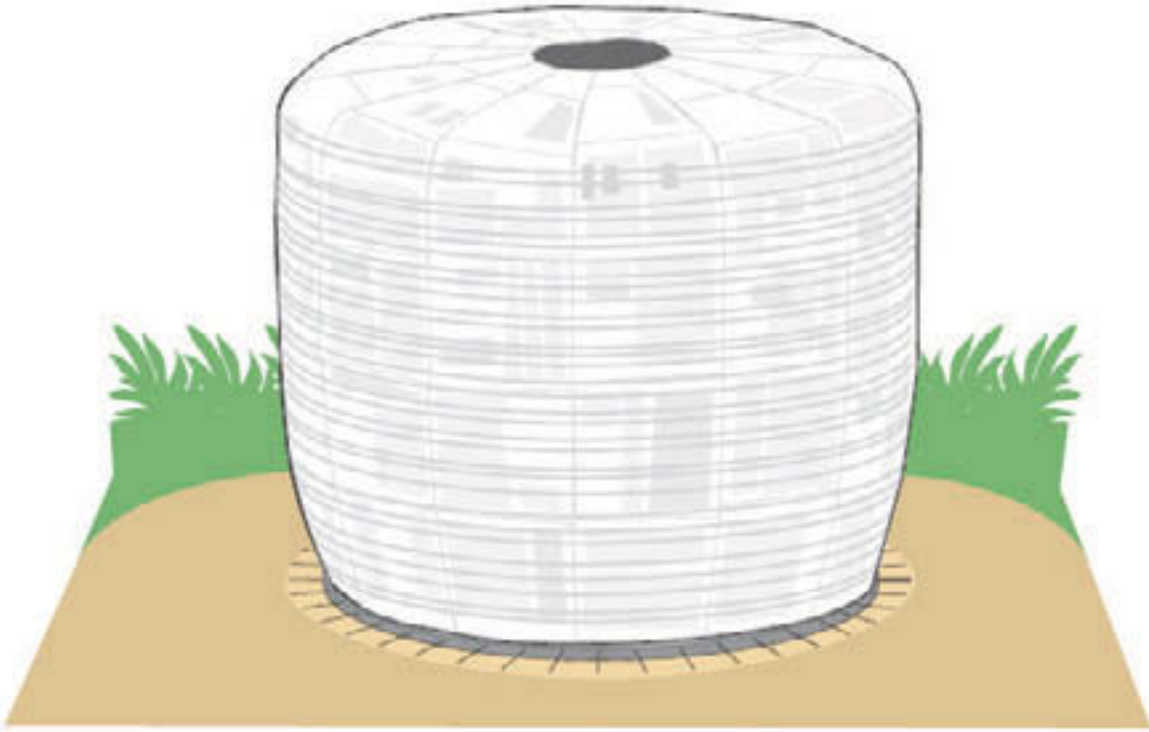

Fig. 25: Starting the tank

Sizing of Pipe Fittings

Inlet - Rainwater catchment

Water comes directly from a catchment area (e.g., sloped roof), and is directed into an opening on top of the tank, or into an inlet pipe. The amount of water collected depends on the area of the catchment surface and the amount of rainfall on any particular day, month, or year. The inlet pipe or downspout should be sized to handle peak rainfall during the rainy season. To calculate pipe size, refer to the resources listed in Appendix G - Further Resources.

Note: Rainwater catchment inlets should be screened to prevent debris or organisms from entering the tank.

Inlet - Piped water system

A piped water system will be designed to carry a specific flow from a water source to the water tank. The diameter of the tank inlet should therefore be equal to the diameter of the transmission pipeline where the pipeline meets the tank.

Outlet pipe

The outlet pipe diameter will depend on the demand placed on the system. The outlet pipe is usually larger in diameter than the inlet pipe in order to accommodate peak water demands. The outlet pipe should be located at least 100 mm above the bottom of the tank to prevent sediment from entering the water supply. The pipe should be located at higher points in the tank if the water is more turbid. If the water tank outlet is a single tapstand located at the base of the tank, the outlet pipe should be a ½ - 1" in diameter.

Overflow pipe

The overflow pipe provides an outlet for any excess water. The diameter of the overflow pipe must be **greater than or equal to the diameter of the inlet pipe**. To avoid eroding the soil beneath the tank, be sure that the overflow water will fall on a concrete splash pad or pile of rocks and be carried away from the tank.

Note: Overflow pipes should also be screened to prevent organisms from entering the tank.

Cleanout pipe

The cleanout pipe is located on the bottom of the tank and is used to drain the tank for disinfection or sediment removal. The drainpipe should be 1½ -2" in diameter in order to handle large particles that may have been caught in the water tank.



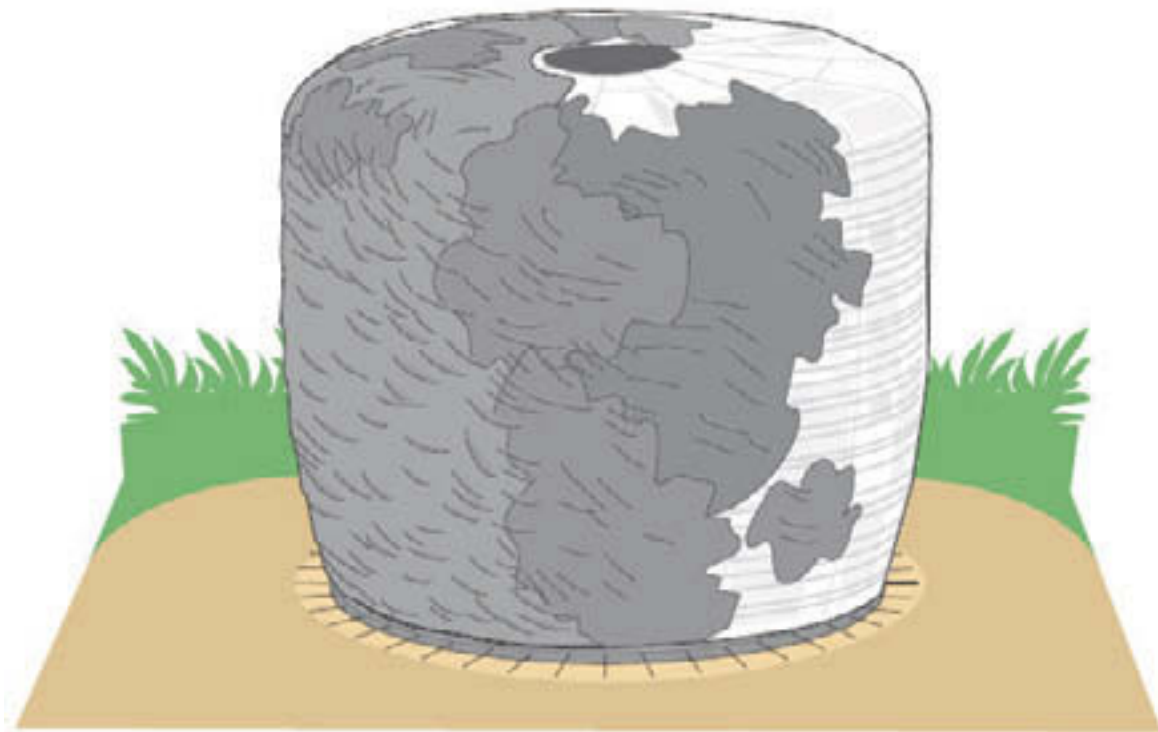
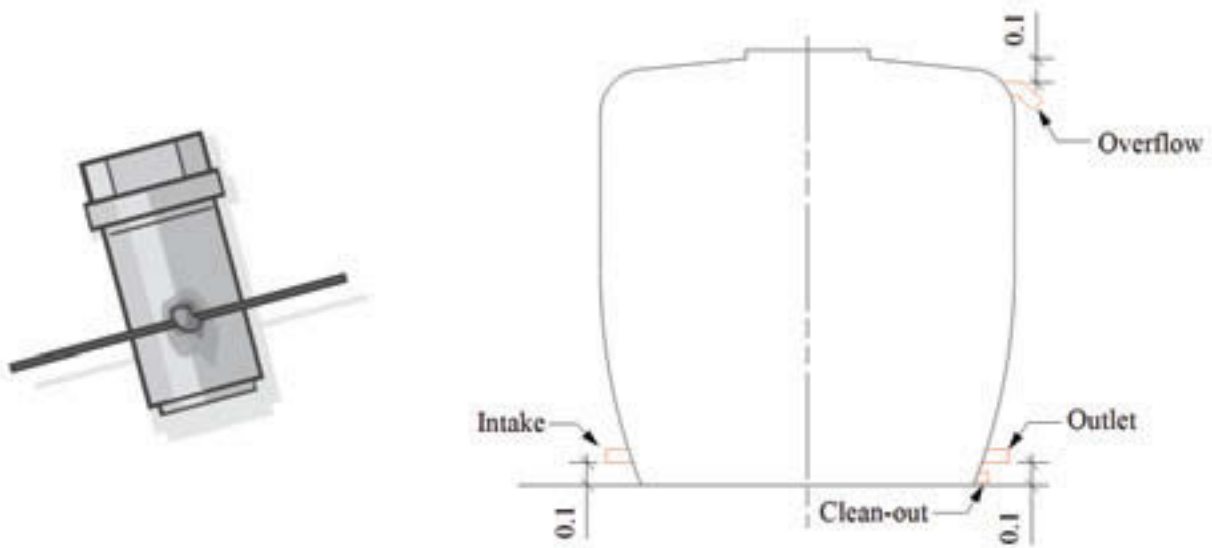

Fig. 26: The first layer

2. Mix a batch of rich cement with screened sand (no gravel) and waterproofing compound. The ratio of cement to sand should be 1:2.5 if the sand is good, otherwise use a ratio of 1:2.
3. Spread a thin rough layer of mortar (approximately 6 mm thick) over the whole tank. The purpose of this first layer is to form the rigid shell over which the subsequent layers can be applied (figure 26). Therefore, when applying the mortar, do not pass the trowel over the mortar repeatedly. Overworking the mortar in this way can cause the layer of newspaper to rip and the mortar to fall off the tank.
4. If the paper rips off, staple new paper over the tear and wait until the next day before plastering over the area. If the mortar slumps off, but the paper is intact, throw some dry cement on the area, wait until the next day, and re-plaster the area.
5. Using wire, attach the fittings for the tank to the frame. Welding a short piece of steel bar to each fitting will ensure that they are properly anchored to the tank wall (figure 27). For a piped system, there should be a cleanout pipe flush with the tank bottom, an intake 10 cm from the bottom, an outlet 10–15 cm from the bottom (depending on water turbidity) and an overflow 10 cm from the top. The intake and outlet should be located on opposite sides of the tank, especially if the water in the tank will be chlorinated. This will ensure that water is effectively treated before exiting the tank (see figure 28 for location of pipes). If the tank is part of a rainwater catchment system, the downspout should be located at the top of the tank. Water can also be fed into a hole placed in the tank lid.



Figs. 27-28: Adding rebar to plumbing fixtures and Plumbing fixture placement

6. Construct the form for the tank rim. This form should be ring shaped, with an outer diameter of at least 60 cm and a height equal to 5 cm plus the estimated thickness of the tank's roof. Once the first layer of mortar has been applied (step 4), center the form over the tank opening (figures 29 and 30).

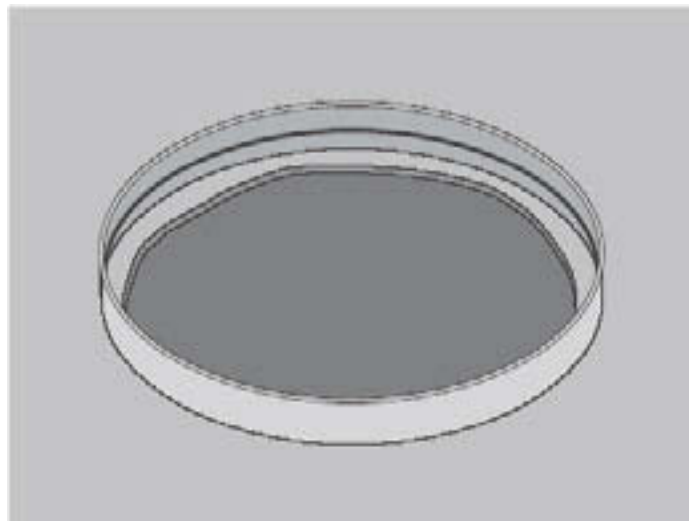

Fig. 29: The rim form

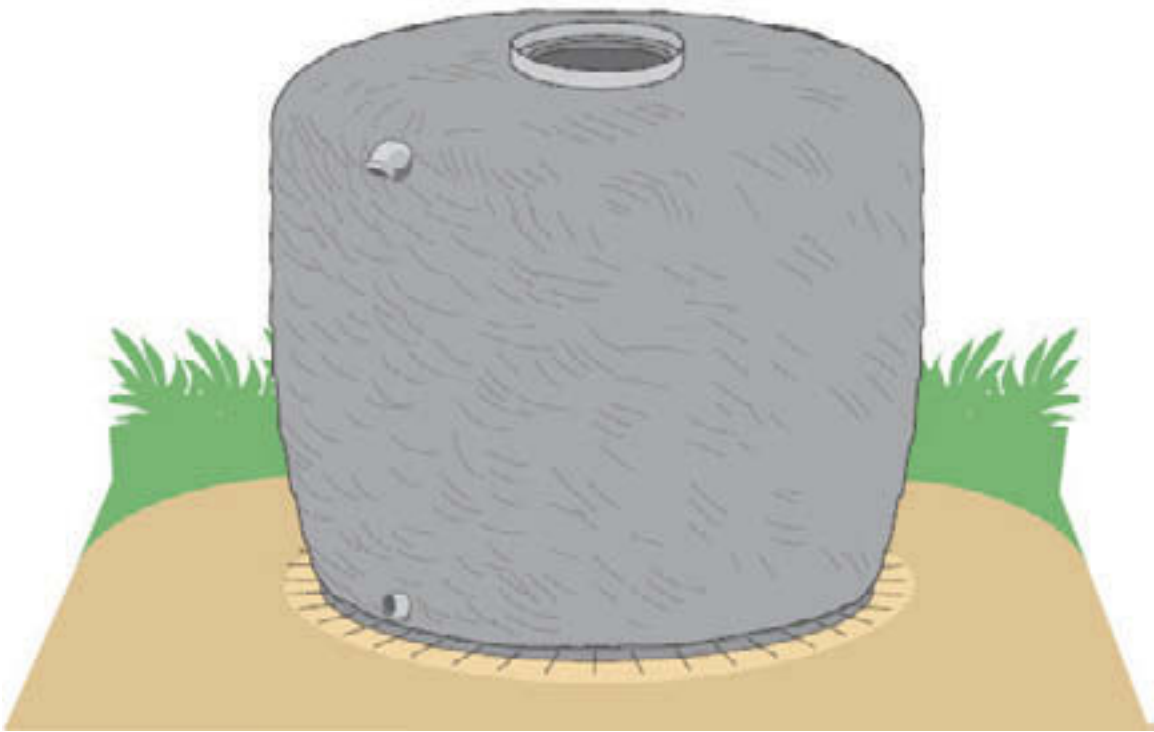

Fig. 30: Jar after first layer of mortar with pipe fittings and rim form

V. Constructing the Tank - Day 2

Attaching the Vertical Wire Supports

These wires connect the tank walls to the base. They also help strengthen the tank against sway stress, which can be caused by earthquakes and high winds.

1. Mix another batch of cement mortar using a 1:3 cement:sand ratio. Plaster another thin layer (6–8mm) over the outside of the tank, filling in the unevenness of the first layer. This second layer should cover the walls and shoulder of the tank but not the entire roof (from the outer edge of the roof to $0.8 \times \text{radius}$ from the roof center; see figure 31). Let the mortar set.



Fig. 31: Second coat of cement mortar

Note: Vertical wires will be attached from the tank bottom, over the roof, to the opposite side of the tank. These wires, in combination with the cement roof, act as a reinforced slab. The wires are most effective if they are located near the bottom of the roof slab, which is why no cement is added to the roof when plastering the second layer (see figure 32).

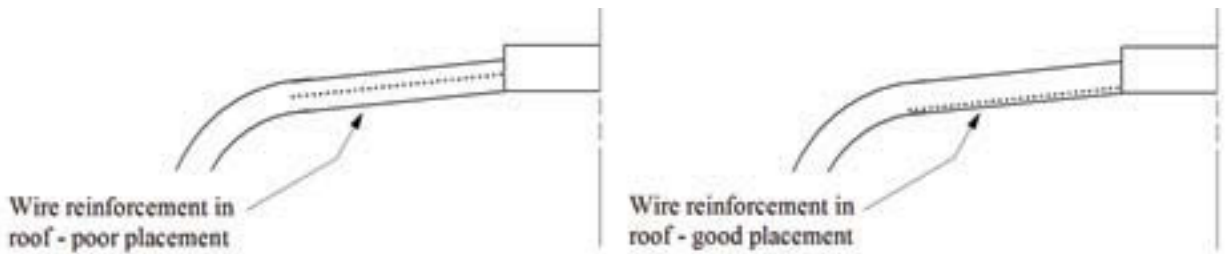

Fig. 32: Roof wire reinforcement placement

2. Attach the end of a spool of #18 wire to one of the wires at the base of the tank. Run the wire up and over the top of the tank. The wire should just touch the edge of the rim form (see fig. 33). Continue running the wire down the other side of the tank and attach it to the nearest set of base wires. Count the number of wires between the first and second connection point; this will be the wire spacing.

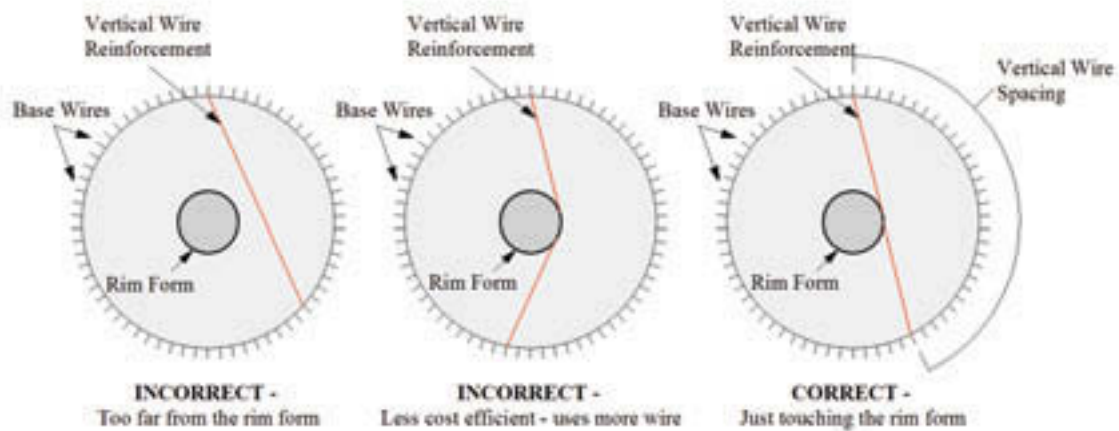
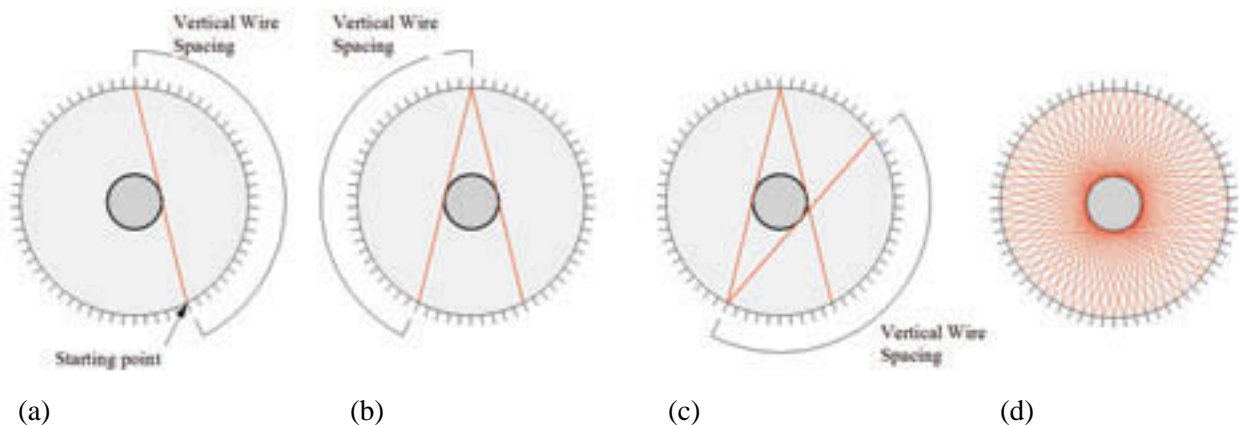

Fig. 33: Top view — correct vertical wire reinforcement placement

3. Once the first wire is in place (figure 34a) use this same spacing to run the wire up and over the tank and attach it to a third set of base wires (figure 34b) and then to a fourth (figure 34c). Continue running the wire over the tank and attaching to base wires until no attachment points are left (figures 34d and 35).



Figs. 34a-d: Top view – Adding vertical wire reinforcement

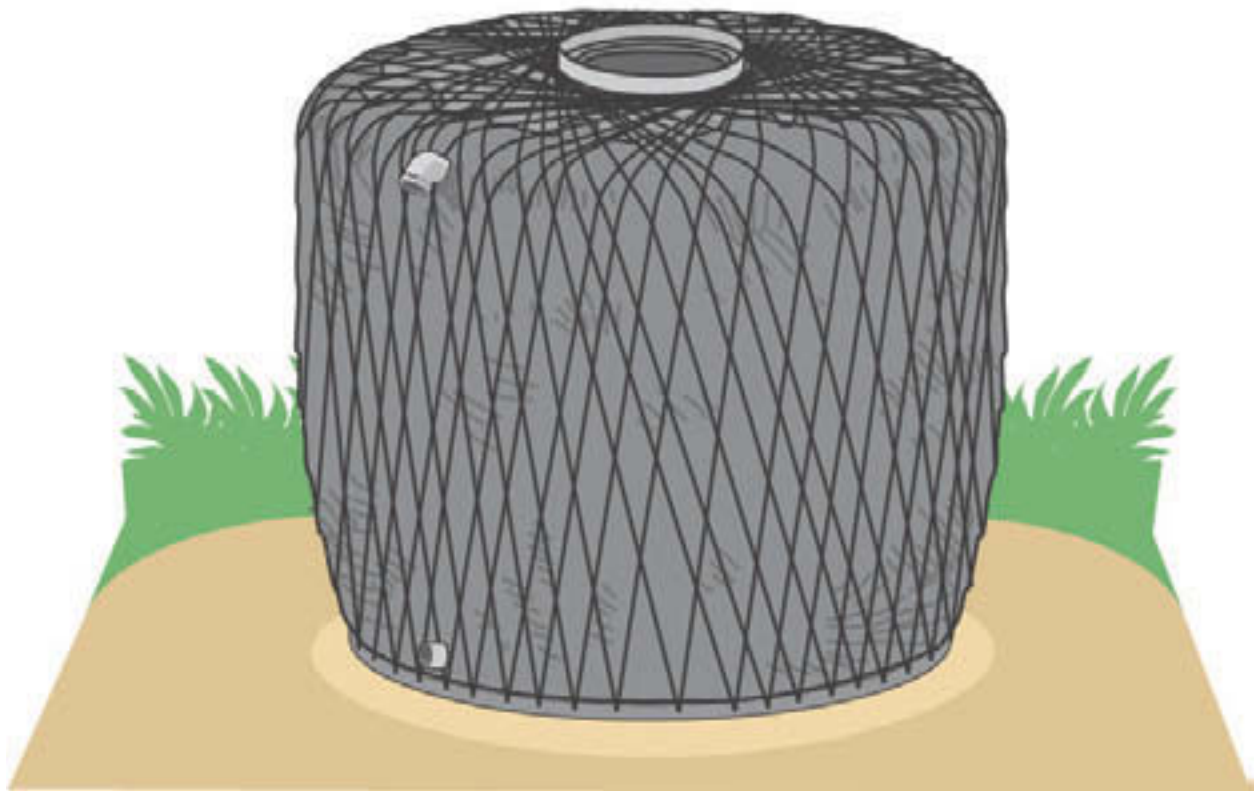

Fig. 35: Jar after completion of vertical wire reinforcement

Horizontal Wire Reinforcement

In order to help support the walls, horizontal wiring must be wrapped around the tank. These wires should be placed *directly over* the vertical wires. Placing horizontal wires in contact with the vertical wires and immediately before the final layer of mortar has several benefits: 1) maximizing the load transfer between the two sets of wire reinforcement by pressing the verticals as close to the mortar as possible, 2) enhancing the effectiveness of the horizontal wires, and 3) minimizing the possibility that water might seep through the cement walls and undermine the tank by causing the wires to rust.

Water in a tank does not exert equal pressure on the sides of the tank. There is less pressure near the top and more pressure towards the bottom. Therefore, the density of wire wrapping is highest towards the bottom of the tank and lowest towards the top. The tanks' planned use also influences the density of wire reinforcement. The cyclic stressing and relaxing caused by filling and emptying can lead to steel fatigue. Thus, tanks that cycle more often have to be stronger. Jars for piped systems empty and load more frequently (several times daily) than rainwater catchment tanks (monthly or even yearly) and therefore need denser reinforcement. Using a series of mathematical equations, the most cost-effective density of wire wrapping can be determined. Details regarding this method can be found in Appendix C: Calculating Horizontal Wire Spacing. A worksheet which calculates wire spacing using this method can be found on this manual's companion CD-ROM.

Horizontal wire placement

1. Using the equations in Appendix C or the Tank Materials Estimator Worksheet on the enclosed CD-ROM, calculate the necessary wire spacing for your tank based on tank volume and height.
2. Using a tape measure, mark the wire spacing on the tank in three or four places, by scoring the cement with a nail. These "spacing guides" will make it easier to maintain consistent spacing.

3. Wrap one end of a roll of #18 wire around the base of the tank and tie it snugly to itself. Then take the rest of the roll and wrap it tightly around the tank following the spacing guidelines you marked. See figure 36 for an example of horizontal wire spacing.

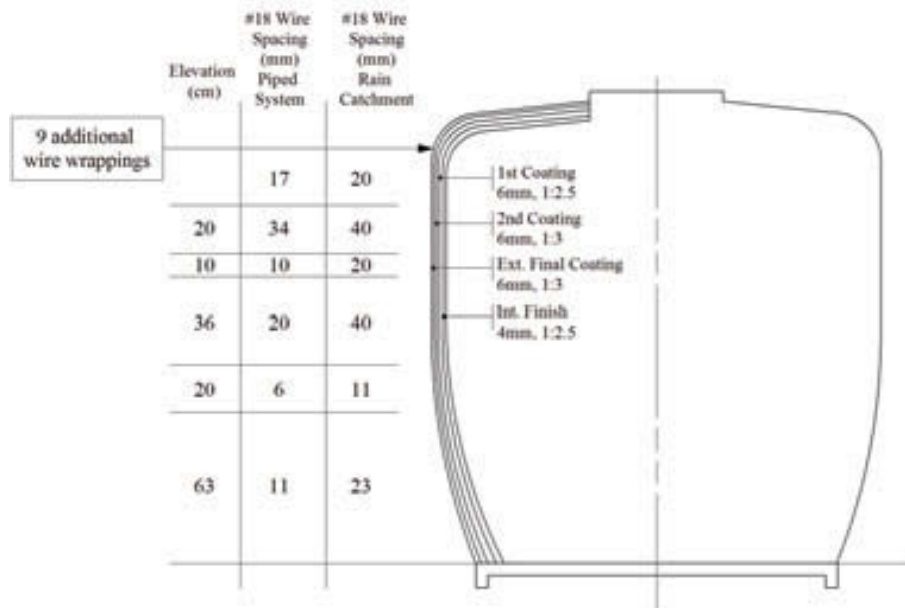

Fig. 36: Example of horizontal wire spacing for a 5,000 L tank

4. When one roll of wire runs out, tie the end to a new roll or tie off the end to itself and start a new roll the same way you began at the bottom. Continue wrapping the tank until the wire begins to slip due to the curve of the tank roof. At this point extra wrappings are needed to counteract thermal expansion of the roof. To determine the number of wire wrappings needed, refer to Appendix C: Calculating Horizontal Wire Spacing.



Fig. 37: Jar after completion of horizontal wire wrapping

5. Once the wrapping is completed, plaster the entire tank with a third layer of mortar (1:3 cement:sand) 6–8 mm thick (figure 38). Add extra mortar to the roof until it has reached its required thickness: 3 cm if the roof has a diameter up to 180 cm, proportionally thicker if roof diameter is larger.

Diameter of roof (cm)	Required roof thickness (cm)
<150	2.5
180	3.0
210	3.5
240	4.0
270	4.5
300	5.0
330	5.5

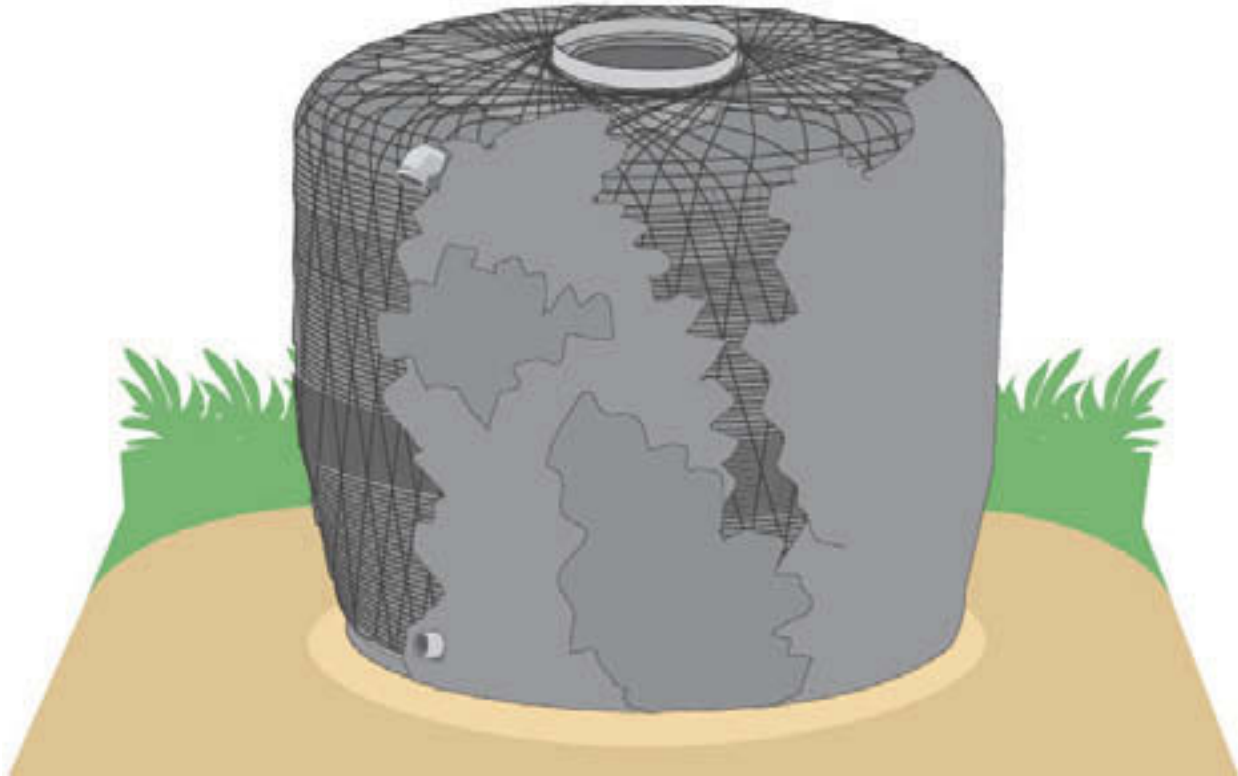
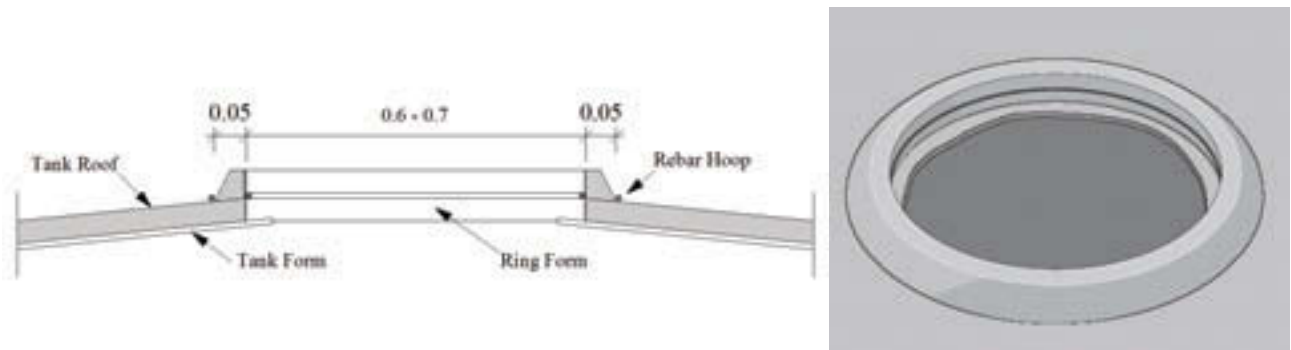

Fig. 38: Applying the final coat of mortar

6. Finally, complete the rim of the tank. To ensure the lid has a good fit, the outside of the rim should slope down towards the roof of the tank (see figures 39–40). Form an steel bar hoop with a radius which is 10 cm larger than the rim form. Later this hoop will be used as part of the lid. In the meantime, it is a guide for constructing the rim. Place the hoop on top of the tank, centered on the rim form. Mix a batch of concrete (1:3 cement:sand) and place the concrete against the rim form. Using a trowel, form a rim that slopes down towards the rebar hoop.



Figs. 39–40: The completed rim

7. Let the tank dry overnight.

Building the lid

The lid of the tank is a shallow ferrocement dome that rests on the tank roof, not the tank lip. The purpose is to prevent rainwater or other contaminants from running off the underside of the lid into the tank.

1. On a clean, level surface (e.g., cement sack, piece of plywood, galvanized iron sheet) build up a clay/sand mound with a height of about 20 cm (figure 41a). This mound will serve as an inner form for the lid. The mound's diameter should be slightly smaller than the rebar hoop used for constructing the rim. Make sure that the slope of the mound is steeper than the slope of the tank's outer rim. When the mound is complete, place rebar stakes around the mound, leaving 3 cm between the stakes and the base of the mound.

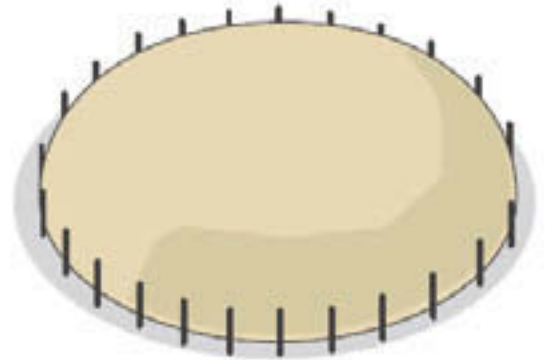

(a)

2. Construct an outer form using sheet-metal strips placed against the inside of the rebar stakes (figure 41b). The diameter of the sheet-metal ring should be about 6 cm larger than the diameter of the sand mound. Cover the mound with wet newspaper; this will prevent the sand from sticking to the lid.

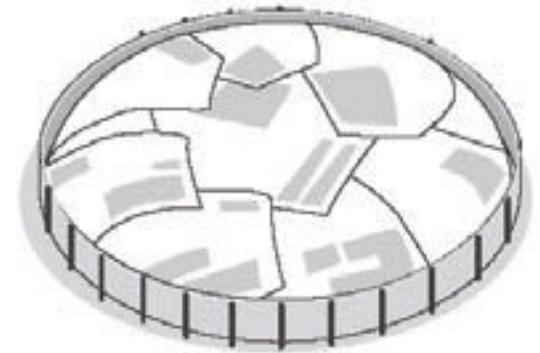

(b)

3. Next, cover the mound with a layer of 1/2" wire mesh. Lay the rebar hoop over the mesh. Form two handles out of 8mm rebar and then lay them over the mesh and tie them to the hoop (figure 41c).



(c)

4. Plaster with a 20 mm layer of cement mortar (1:3 cement:sand). Let the mortar set (figure 41d). Once the mortar has hardened, cover the lid with sacking and keep the lid damp to promote proper curing of the cement. To minimize cracking, the lid should be allowed to cure for at least two days before it is moved.

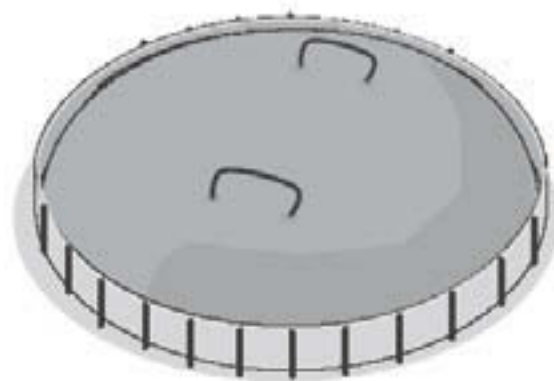

(d)

5. After two days, remove the lid from the forms and remove any excess newspaper with a wire brush. Finish the underside of the lid with a thin coating of cement slurry (1:2.5 cement:sand).

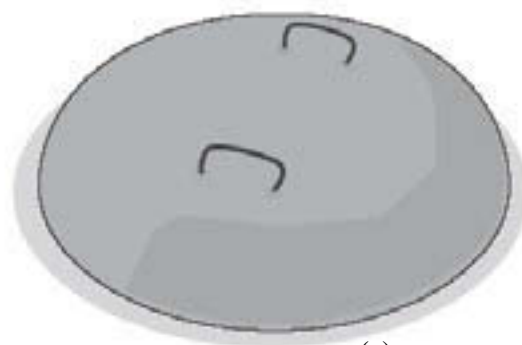

(e)

Figs. 41a-e: Constructing the lid

VI. Constructing the Tank — Day 3

Finishing the Tank

1. Remove the rim form from the top of the tank.
2. Climb inside the tank and cut the wires holding the form pieces together.
3. Remove the form pieces and as much newspaper as possible (Fig. 42). Use a wire brush to remove any paper that will not peel away.
4. Apply a final layer of cement (1:2.5 cement:sand ratio) with waterproofing compound on the inside floor and walls (see figure 43), then let the entire tank cure for at least one week.

Alternatives for Finishing

Plastering the inside walls with a thin layer of cement mortar and waterproofing compound is the most common way to finish the tank. There are also two alternative methods. First, a pozzolan cement can be used for the final inner layer of mortar. Materials in the pozzolan cement will react with lime to form compounds which make the cement more watertight and crack resistant. Using pozzolan cement for this final layer can help reduce leaking if calcareous sand was used. Second, once the tank has cured, the inside can be painted with natural or acrylic latex paint.

5. While the tank cures, keep it wrapped in sacking or plastic.
6. Twice a day, morning and evening, remove the covering and wet the tank down with water, inside and out. Once the cement dries out, it stops hardening. Therefore, in order to have the strongest tank possible, the mortar must be kept wet for at least one week
7. After one week, begin filling the tank. On the first day, fill it to a depth of 30 cm. On each subsequent day, add 15 cm of water until the tank is full.
8. If any leaks develop, simply drain the tank and patch the cracks with mortar.



Fig. 42: Removing the form

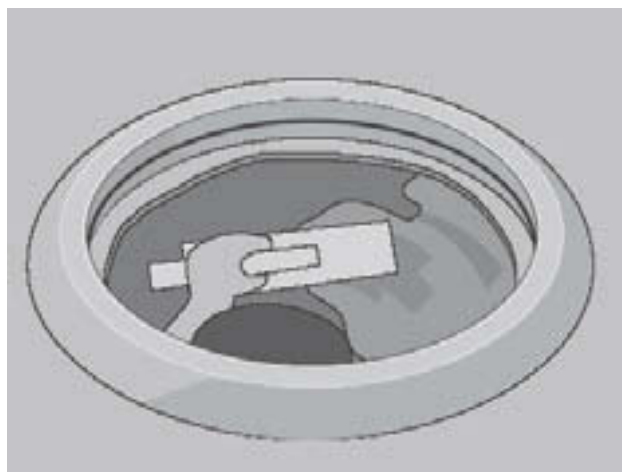

Fig. 43: Applying a final layer of mortar inside the tank

VII. Building Larger Tanks

When the volume of wire-reinforced jars exceeds 20,000 L, certain aspects of the construction and design process must be modified in order to maintain structural integrity. There are also modifications that are not required, but that can help to reduce costs.

Required

- To address increasing weight and pressures, the base should be thicker than it would be for smaller tanks. For example, when constructing a 30,000 L tank, the base will rest on a pad of packed gravel 7 cm thick and will have a total thickness of 10 cm, including the final inner layer of cement mortar. The base would also include two layers of wire reinforcement.
- The base of the tank walls also needs to be thicker for a large tank. For a 30,000 L tank, an additional set of horizontal wire wrapping and an additional layer of cement mortar are added to the bottom 90 cm of the tank (figure 44).

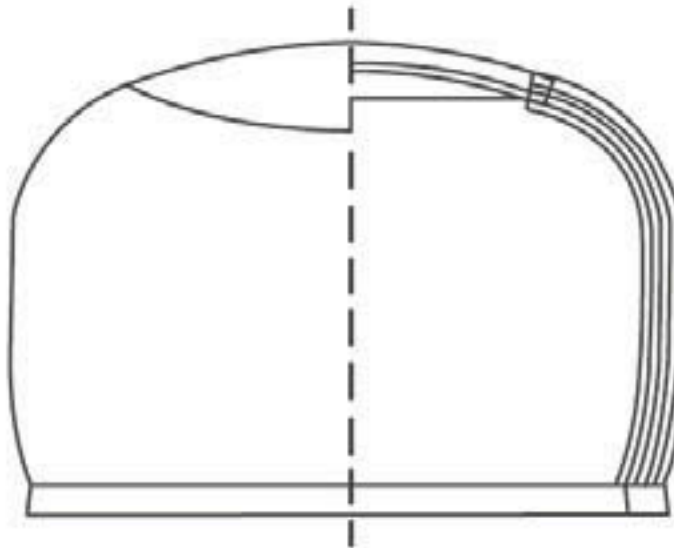

Fig. 44: Wall thickness of a 30 m³ wire-reinforced ferrocement jar

Optional

- Particularly when constructing tanks with a height greater than 1.80 m, it may be helpful to construct scaffolding over the tank.
- As the tank gets larger, its roof span and diameter also increase. The roof, if cast as a single piece, would need to be thicker, and for larger tanks this can be expensive. An alternative that uses less material is to cast only the shoulder of the tank (60–135 cm from the edge of the tank, depending on size) integral with walls, but not the entire roof. The wide hole left open can be closed by a domed cap cast over the roof, which rests on the tank's shoulder and is not connected by reinforcing wires (figure 45). A second advantage of two-piece roof construction is that it minimizes scaffolding. The roof edges (shoulders) can first be cast with the walls. Then the cap mold is assembled, fastened to the tank, and the cap cast by people crouching on the roof edge.

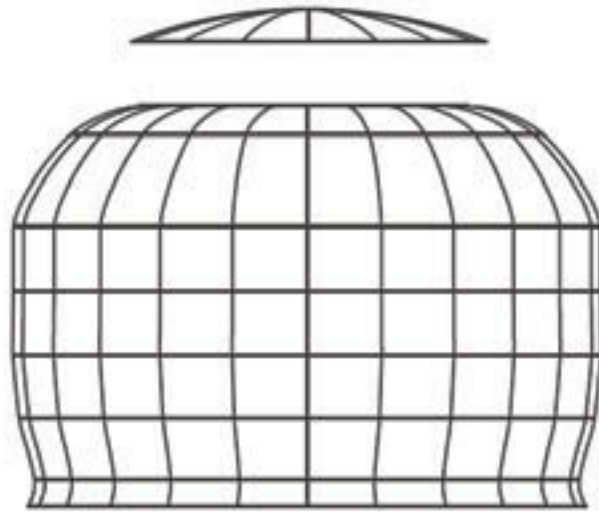

Fig. 45: Tank with roof cap

- In tanks with two-piece roofs, the manhole can be cast on the roof edge, instead of at the center. This placement makes it easier to construct the manhole plus people having to enter the tank do not need to walk near the middle of the roof, where their weight would necessitate a thicker roof cap.

NOTES

PART B

CONSTRUCTING A 5,000 LITER WIRE-REINFORCED JAR

I. Determining Tank Size

As an example, the following section will detail the construction process for a 5,000 L (5 m^3) tank. Please note that, while the techniques are broadly applicable to a range of tank sizes, measurements and calculations are specific to a 5,000 L tank and would be different for other sizes.

II. Determining Tank Shape

Figure 46 illustrates the shape used for the 5,000 L ferrocement tank. The design was created using the steps in Appendix B - Determining Tank Shape, through which the curvature of the upper and lower portions of the tank was determined. The design is also one of the samples included in Appendix C. From the sample design, vertical pieces were measured to be 2.47 m long and 7 horizontal hoops ranging in diameter from 0.55 m to 1.90 m were needed (see Appendix D).

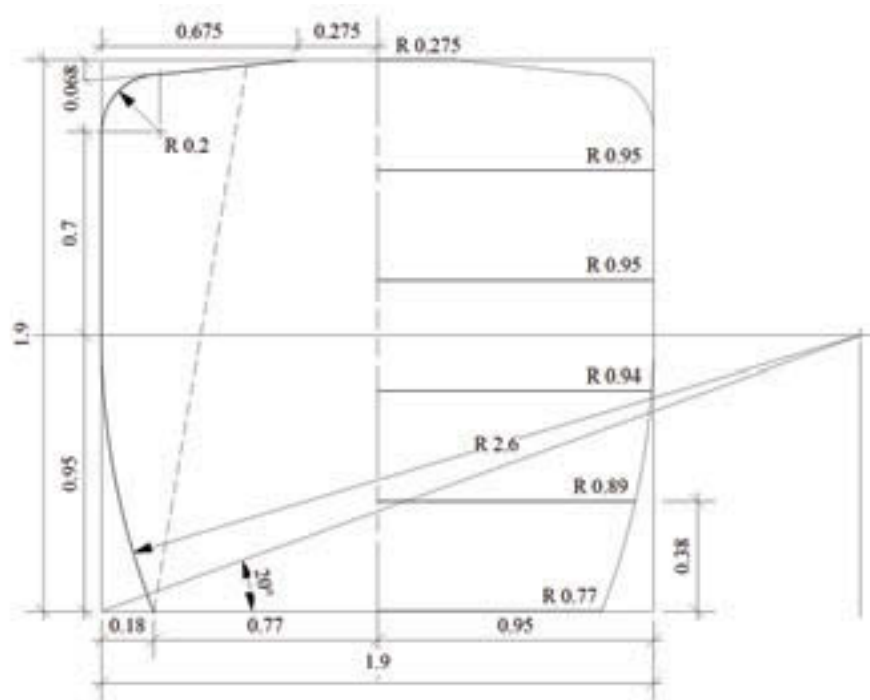

Fig. 46: Shape of a 5,000 liter tank

III. Building the Form

Tools and Materials

The following tools and materials are needed to construct the form.

Materials¹

31 pieces	8 mm rebar (6 m in length)
18 m ²	½” wire mesh
1 kg	#18 steel wire welding rod paint newspaper cassava or laundry starch

Tools

hacksaw
tape measure
hammer
pieces of scrap lumber
chalk
nail and string
wire cutters
welding machine
paintbrushes

Vertical Pieces

1. Calculate tank circumference (C).
2. Diameter² of the 5,000 L tank is 1.90 m

$$C = \text{Diameter } (\varnothing) \times \pi$$

$$\varnothing = 1.90$$

$$\pi = 3.14$$

$$C = \varnothing \times \pi = 1.90 \times 3.14 = \mathbf{5.97 \text{ m}}$$

3. Calculate the number of vertical pieces needed

$$\# \text{ of verticals} = 6.66C$$

$$C = 5.96$$

$$\# \text{ of verticals} = 6.66C = 5.97 \times 6.66 = 39.76 = \mathbf{40}$$

4. Based on figure 46, each vertical piece is 2.47 m long. Cut 40 pieces of steel bar of this length, and bend into the proper shape.

¹ Material estimate from “Form Material Estimator” Spreadsheet.

² Diameter determined in Appendix B - Determining tank shape.

Horizontal Pieces

1. From figure 46, we know that we need to form six hoops of the following sizes:

Number of Hoops	Diameter of Hoop (m)	Length of Rebar (m)
1	0.55	1.73
2	1.90	5.97
1	1.88	5.90
1	1.78	5.59
1	1.54	4.84

2. Cut pieces of these lengths and bend them into hoops. Divide the largest hoop into 30 sections, each 19.9 cm wide. Mark these divisions on the hoop with paint or a permanent marker to indicate where the vertical pieces should be welded. Transfer these markings to the remaining hoops using the method illustrated in figure 16.
3. Then, take the pieces to a welding shop and have them welded together. Remember, the horizontal hoops should be on the *inside*, and the vertical pieces on the outside.
4. Once the form is welded, the frame will be divided into 10 equal pieces — each approximately 60 cm wide at its widest point. Measure along the largest hoop, marking out where the form will be cut apart. At each of these locations, weld an additional vertical piece. Then, cut the form into pieces making sure to cut between these “double verticals.”

Note: the widest point cannot be larger than the opening for the tank; otherwise the pieces cannot be removed at the end of the building process.

5. Cover each piece with ½” wire mesh. Be sure the mesh is stretched tightly across the frame and tie it to the form with wire. The tank will need approximately 18 m² of mesh. Paint the form to prevent corrosion.
6. Cover the wire mesh with three layers of newspaper. The first two layers should be dipped in a 1:8 mixture of cassava starch (or flour) and water. The final layer should be laid onto the form without any additional starch. Let the paper dry completely. This layer of paper will prevent the cement from sticking to the form.



Figs. 47–48: Completed form pieces

IV. Constructing the Tank - Day 1

Tools and Materials

Materials³

0.8 m ³	screened, noncalcareous sand
0.2 m ³	gravel
8 bags	Portland cement (40 kg bag)
8 bags	waterproofing compound
12.5 kg	#18 (1.4 mm) steel wire
4 pieces	8 mm steel rebar (6 m pieces)
1 piece	2" diameter x 4" GI nipple w/end cap (cleanout)
1 piece	1" x 4" GI nipple (inlet)
2 pieces	2" diameter x 4" GI nipple (outlet and overflow)
1 piece	2" gate valve
0.25 piece	flat Galvanized Iron sheet (0.8 x 2 m)
1	tank form

Tools

wire cutters
hacksaw
shovels
buckets
tin snips
pliers
measuring box
spirit level (carpenter level)
wire brush
tape measure
screen or sand sieve
masonry trowels and floats
extra cement sacks or newspapers

Building the Tank Base

1. Clean and level the area where the tank will be built.
2. The diameter of the base should be 1.57m. Mark out the location of the base with rebar stakes every 0.1 m. Then form a rebar ring (inner diameter = 1.57 m) and attach it to the inside of the stakes. Using the ring as a guide, dig a circular hole along the inside of the ring, 0.05 m (5 cm) deep (figure 49).
3. Around the inner edge of the hole, dig a trench 0.1 m (10 cm) wide and 0.1 m (10 cm) deep. Line the bottom of the hole and the trench with gravel, tamping the gravel down to anchor the stones in the soil (see fig. 50).

³ Material estimate from "Tank Materials Estimator" Spreadsheet



Fig. 49-50: Excavating the base and Adding gravel

4. To strengthen the base, form a hoop out of rebar with a diameter of 2.1 m. Mix a batch of concrete (1:2:4 cement:sand:gravel) and fill the outer trench halfway. Place the rebar hoop in the concrete and fill the trench the rest of the way.
5. Next, add wire reinforcement across the base every 0.125 m (12.5 cm). Then, add a second layer of wires, again every 12.5 cm. The wires in this second layer should be placed perpendicular to the wires in the first layer, creating a 12.5 cm² mesh. Be sure to leave 0.15 m (15 cm) of excess wire hanging off on both sides. When the wires are in place, line the foundation with strips of sheet metal 0.05 m high. (see figure 51, noting that strips of banana stalk were used in place of sheet metal).



Fig. 51: Adding base reinforcement

6. Once the reinforcement is in place, mix a batch of concrete (1:3:5 cement:sand:gravel) with waterproofing compound and pour onto the base. Make sure the excess wires are not covered by concrete. Let the base cure overnight.



Figs. 52-53: Pouring cement and The completed base

Starting the Tank

1. When the base has set, reassemble the form, tying the individual pieces together with wire (figures 54-55). Be sure to assemble the form on a flat even surface to ensure proper alignment.



Figs. 54-55: Assembling the form

2. Remove the rebar stakes, the rebar hoop and the sheet-metal strips from around the base. Set the form on the base. Be sure that the wires sticking out from the base are not caught under the form. Place bags of sand or gravel against the inner wall of the form to prevent the form from moving during initial plastering. Wrap the form in #18 steel wire every 10 cm.



Fig. 56: The completed form

3. Mix a batch of rich cement mortar (1:2.5 cement:sand) with screened sand (no gravel) and waterproofing compound.
4. Next, spread a rough 6 mm layer of mortar over the whole tank.



Fig. 57: Plastering the first layer

5. Construct the inner form for the tank lip out of sheet metal and an steel bar hoop. This form should be ring shaped, with an outer diameter of 65 cm and a height of 9 cm. Once the first layer has been applied, center the ring form over the manhole opening.
6. Before the first layer has set, attach the hardware for the tank to the form — a cleanout valve on the bottom, an intake 10 cm from the bottom, an outlet 10 cm from the bottom and an overflow 10 cm from the top. Weld a short length of steel bar to each fitting (see figs. 58–59). This will anchor the fittings in the tank wall.



Figs. 58–59: Attaching pipe fittings

V. Constructing the Tank - Day 2

Vertical Wire Supports

1. On day 2, mix another batch of cement mortar (1:3 cement:sand). Plaster an 8 mm layer over the outside of the tank, filling in the unevenness of the first layer. This second layer should cover the walls and shoulder of tank, but not the roof (figure 60).



Fig. 60: Plastering the second layer

2. Next, attach the vertical wire supports. Attach the end of a spool of #18 wire to one set of the wires at the base of the tank. Run the wire up and over the top of the tank. The wire should just touch the edge of the rim form. Continue running the wire down the other side of the tank and attach it to the nearest set of base wires. Next, count the number of wires between the first and second connection point, this will be the wire spacing (See figures 61-62).



Figs. 61–62: Wire placement in relation to the rim, and Connecting the wire to the tank base

3. Continue running the wire up and over the tank and attaching it to the connection points until there are no connection points left. Figure 63 illustrates a tank with completed vertical wire reinforcement.



Fig. 63: Completed vertical wire reinforcement

Horizontal Wire Reinforcement

As discussed in the general instructions, a series of mathematical equations are used to calculate the most cost effective horizontal wire wrapping density. Details regarding this method can be found in Appendix C - Calculating Horizontal Wire Spacing and sample designs based on the equations are included in Appendix D. Figure 64 is an example of one such sample design and includes wire spacing for tanks used in rainwater catchment and piped water systems.

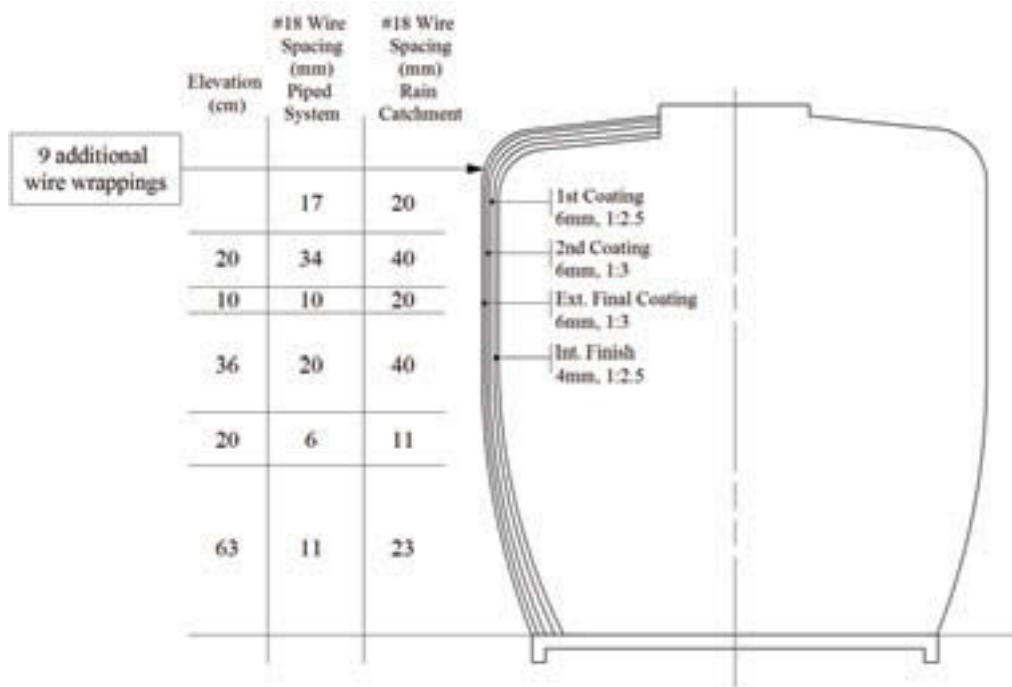

Fig. 64: Wire wrapping for a 5,000 liter tank (h = 1.9 m)

1. This tank will be part of a piped system. Using a tape measure, mark the wire spacing on the tank in three or four places, by scoring the cement with a nail. These “spacing guides” will make it easier to maintain consistent spacing.



Fig. 65: Marking horizontal wire placement

2. One end of a spool of #18 tie wire is wrapped around the tank and tied to itself, either at the very top or very bottom of the tank. Then the tank is wrapped with wire according to the spreadsheet numbers. In this case the first section of wrapping would be placed every 11 mm if starting from the bottom or every 17 mm if starting from the top.



Fig. 66: Horizontal wire reinforcement

3. At the point where the wire begins to slip at the tank shoulder, extra wrappings will be needed to counteract thermal expansion of the roof. Using the equation in Appendix C shows that a 5,000 L tank with a height of 1.9 m needs 9 extra wrappings at the shoulder.
4. Once the wrapping is completed, plaster the roof with more mortar until it has reached a total thickness of 30 mm.
5. Plaster the remainder of the tank with a third layer of mortar (1:3 cement:sand) 6 mm thick (Figure 67).



Fig. 67: Applying the final layer

6. Complete the rim of the tank. To ensure a good fit with the lid, the rim should slope down towards the roof of the tank (see figure 68). Form an steel bar hoop with a radius of 75 cm and place it on top of the tank, centered on the inner form. Later, this hoop will act as a lid reinforcement.
7. Mix a batch of mortar 1:3 cement:sand. Place the mortar against the inner form. Using a trowel and the steel hoop bar as a guide, form a sloping rim.
8. Let the tank dry overnight.



Fig. 68: Forming the rim

Building the lid

For tanks less than 20,000 L, the size, shape and construction methods of the lid are the same. Use the methods described in Part I - General Instructions for Constructing a Wire-Reinforced Jar.

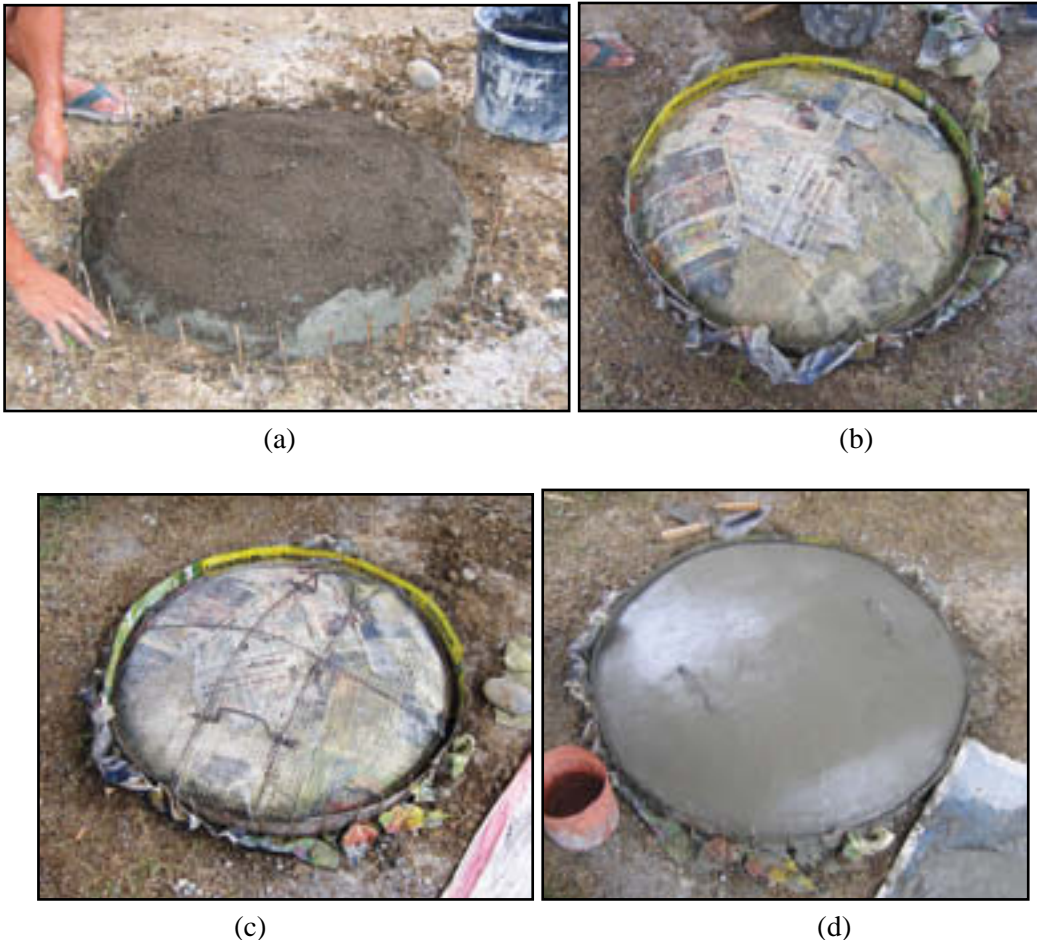

Figs. 69a-d: Constructing the lid

VI. Constructing the Tank — Day 3

Finishing the Tank

1. On the third day, remove the ring form from the top of the tank.
2. Climb inside the tank and cut the wires holding the form pieces together. Remove the form pieces and as much newspaper as possible. Use a wire brush to remove any paper that will not peel away.



Fig. 70: Removing the form

3. Apply a final layer of cement mortar (1:2.5 cement:sand with waterproofing compound), 4 mm thick, on the inside of the tank (floor and walls). The floor should slope towards the cleanout (figure 71).



Fig. 71: Plastering the inside of the tank

4. Let the entire tank cure for at least one week. While the tank cures, keep it wrapped in sacking or plastic. Twice a day (morning and evening), remove the covering and wet the tank down with water, inside and out. Once cement dries completely, it stops hardening. Therefore, in order to have the strongest tank possible, the mortar must be kept wet for at least one week
5. After one week, begin filling the tank. On the first day, fill it to a depth of 30 cm. On each subsequent day, add 15 cm of water until the tank is full.



Fig. 72: Completed tank



Fig. 73: Completed Tank with lid, valve box and optional splash-pad for erosion prevention

NOTES

APPENDICES

Appendix A - Tank Materials Cost Comparison

The following chart compares the material costs for a 10,000 L water tank using different construction methods. These estimates include the cost of tank materials, any necessary formwork and labor. They do not include engineering and transport costs. Prices for materials and labor are based on prevailing prices in Davao City, Philippines on July 23, 2005. (1USD = 56PHP)

TANK	Price (PHP)	Wire Reinforced Jar — Rainwater Catchment ¹		Wire Reinforced Jar — Piped System ¹		Cylindrical Ferrocement — Wire Reinforcement ²		Sri Lankan Pumpkin Tank ³		Cylindrical Ferrocement — Iron Bar Reinforcement		Poured Concrete ⁴	
		Quantity	Total	Quantity	Total	Quantity	Total	Quantity	Total	Quantity	Total	Quantity	Total
Portland cement (40 kg sack)	160	13.00	2,080	13.00	2,080	15	2,400	16	1,920	16	2,560	29.28	4,684
Sand (cubic meter)	450	1.10	495	1.10	495	1	450	1	600	1.2	540	1.96	881
Gravel (cubic meter)	450	0.40	180	0.40	180	0.5	225	0.2	120	0.5	225	3.92	1,762
Sahara waterproofing compound (bag)	25	13.00	325	13.00	325	0	-	1	27	-	-	29.28	732
#18 tie wire (kg)	52	16	832	26	1,352	0	-	1	35	-	-	6	312
8 mm iron rebar	42	4	168	4	168	0	-	4	300	-	-	0	-
10 mm iron rebar	75			0	-					25	1,875	75	5,625
2" diameter x 4" GI nipple with end cap	50	1	50	1	50	1	50	1	50	1	50	1	50
1" x 4" GI nipple	50	1	50	1	50	1	50	1	50	1	50	1	50
2" diameter x 4" GI nipple	40	1	40	1	40	2	80	2	80	2	80	2	80
2" gate valve	500	1	500	1	500	1	500	1	500	1	500	1	500
3mm screen (m ²)	45	1	45	1	45	1	45	1	125	1	45	1	45
2.5mm wire (kg)	52	0	-	0	-	15	780	-	-	-	-	0	-
Chicken wire (square meter)	40	0	-	0	-	16	640	75	3,000	-	-	0	-
½" wire mesh	36	0	-	0	-	0	-	-	-	25	900	0	-
GI Sheet (.8 x 2 m)	176	0	-	0	-	4	704	-	-	-	-	0	-
2" x 2" angle iron (6 m)	150	0	-	0	-	2	300	-	-	-	-	0	-
Subtotal			4,765		5,285		6,224		6,807		6,825		14,721
Contingency Costs		5%	238	5%	264	5%	311	5%	340	5%	341	5%	736
			5,003		5,549		6,535		7,147		7,166		15,457
Form ⁵			300		300		367		470		-		412
Labor — skilled (days)	350	5	1,750	5	1,750	6	2,100	7	2,450	7	2,450	5	1,750
Labor — unskilled (days)	150	10	1,500	10	1,500	12	1,800	14	2,100	14	2,100	10	1,500
			3,250				3,900		4,550		4,550		3,250
TOTAL (PHP)			8,553		9,099		10,802		12,167		11,716		19,119
TOTAL (USD)			\$ 153		\$ 162		\$ 193		\$ 217		\$ 209		\$ 341

¹ Estimate based on Ferrocement Tank Estimator Worksheet.

² Estimate based on a materials list for a 10 m³ cylindrical tank with a galvanized iron roof in S.B. Watt's "Ferrocement Water Tanks and Their Construction."

³ Estimate based on a 10 m³ cube-shaped tank with reinforced concrete floor, walls and roof (10 cm thickness).

⁴ Estimate based on "Rainwater Harvesting for Domestic Use in Sri Lanka" by T. Ariyananda and Material Lists for 8 m³ and 5 m³ Pumpkin Tanks (e-mail T. Ariyananda 10/04).

⁵ Assumes that form is used to build 10 tanks, except for the poured concrete tank, which assumes 5 uses.

Appendix B - Determining Tank Shape

Use the tank volume estimator spreadsheets on the included CD-ROM or a resource listed in Appendix E to calculate what size tank is needed. Remember that, given the placement of the overflow and the tank outlet, some storage volume is lost. Therefore, size the tank about 10% larger than the water demand indicates.

Once the tank volume has been determined, it is time to design the tank's shape. Designing this type of tank involves some mathematics. **To make things easier, the specifications for a selection of common sizes can be found in Appendix D of this manual.** If the size needed is not listed in the appendix, use the following method to determine the shape of the tank. The Form Material Estimator spreadsheet, found on the CD-ROM which accompanies this manual, can be used to determine the most cost-effective height/diameter ratio and to estimate the quantities of mesh and rebar needed to construct the form.

Determining Tank Shape

1. Begin by imagining your tank to be a cylinder.

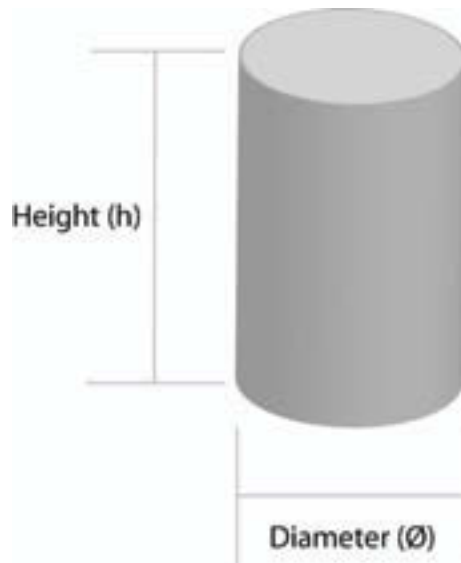

Fig. 74: Cylinder

2. The ratio of the cylinder's height to its diameter ($\frac{h}{\phi}$) should be between 0.75 and 1.20. This will ensure tank stability.

Choose a height and solve for the area of the cylinder's base. (2.1 m is a good height for tanks 6,000–10,000 L.)

$$V = A_C \times h$$

$$\text{so, } A_C = \frac{V}{h}$$

Where,

V = volume

A_C = area of circle

h = height

3. Once the Area (A_c) is determined, use the following equation to determine the diameter (ϕ).

$$A_c = \frac{(\pi \times \phi^2)}{4}$$

$$\text{so, } \phi = \sqrt{\frac{4 \times A_c}{\pi}}$$

Where,

A_c = Area of the circle

ϕ = Diameter of the circle

π = Pi (3.14)

4. Check to make sure that the ratio of height to diameter ($\frac{h}{\phi}$) falls between 0.75 and 1.20.

Example: A 4,000 L tank (4 m^3) with 1.5 m as the chosen height.

$$V = 4 \text{ m}^3$$
$$h = 1.5 \text{ m}$$

$$A_c = \frac{V}{h} \quad A_c = \frac{4}{1.5} \quad A_c = 2.67 \text{ m}^2$$

$$\phi = \sqrt{\frac{4 \times A_c}{\pi}} \quad \phi = \sqrt{\frac{4 \times 2.67}{\pi}} \quad \phi \approx 1.9 \text{ m}$$

$$\frac{h}{\phi} = \frac{1.5}{1.9} = 0.8 \quad \text{This size will work.}$$

Determining Tank Shape II

1. The next step is to calculate the curves that give the tank its jar shape. Draw the top as a rectangle, leaving a 0.5–0.7 m opening for a maintenance hatch (figure 75).

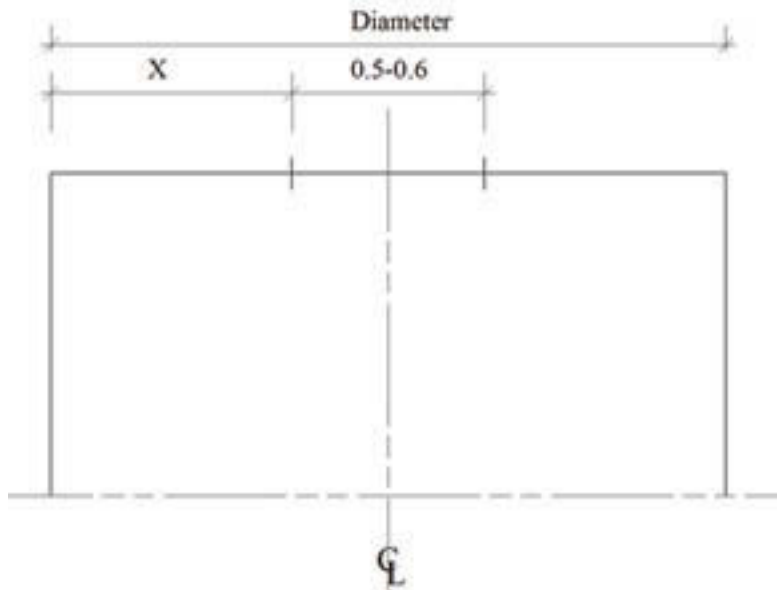

Fig. 75: Tank shape, top — Step 1

2. Draw the top of the tank; it slopes down 1–2 cm for every 10 cm of distance (slope = $-1/10$) (figure 76).

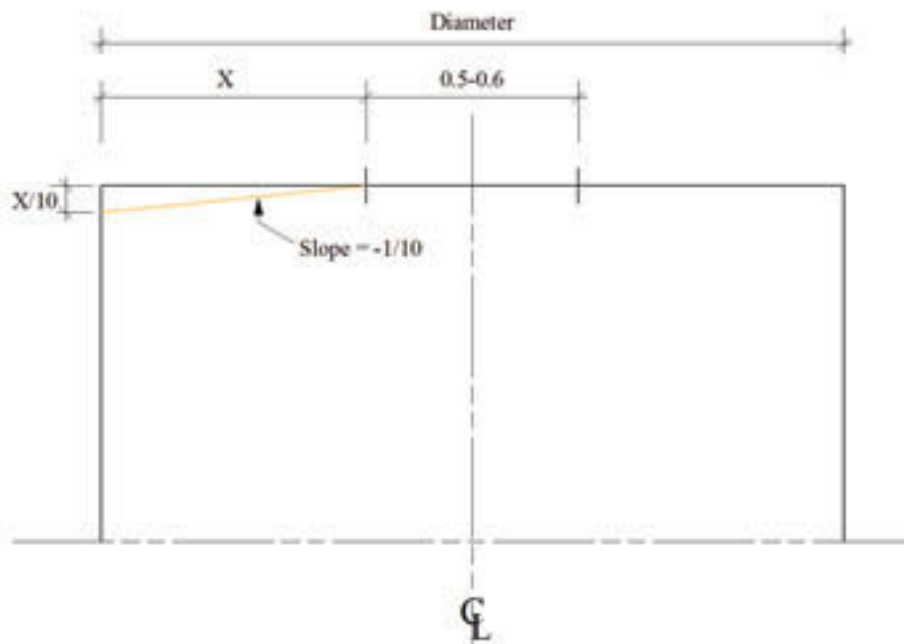

Fig. 76: Tank shape, top — Step 2

3. At the edge, it curves downward to meet the vertical wall of the tank (figure 77). This curve has a radius of 0.1–0.3 m depending on the size of the tank (the smaller radii can be used for smaller tanks).

Radius of curvature (m)	Tank Size (m ³)
0.1	<5
0.2	5–15
0.3	>15

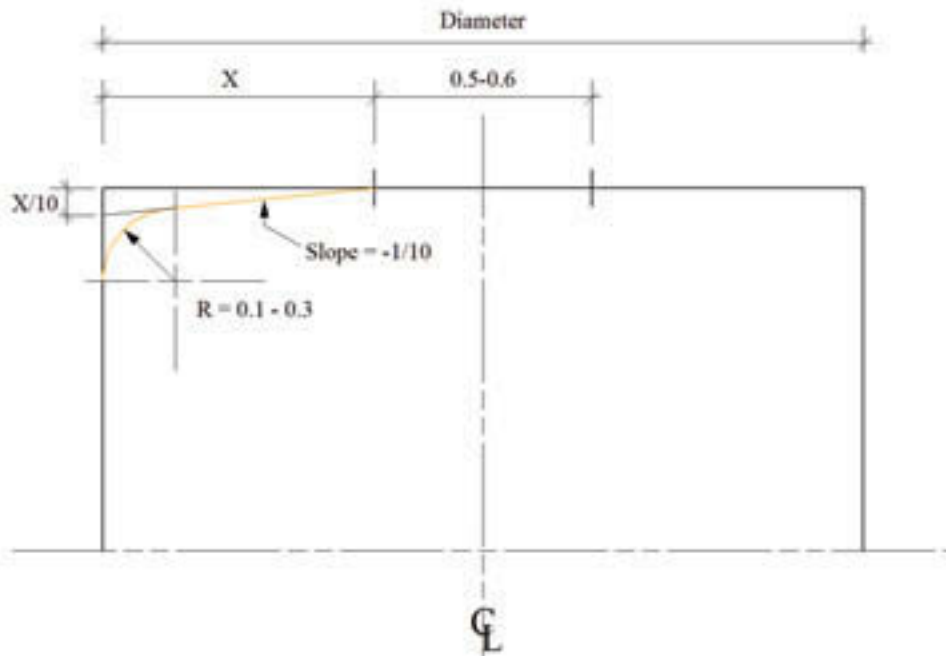

Fig. 77: Tank shape, top — Step 3

- Determine the curve of the tank bottom. First, draw the bottom of the tank as a rectangle and draw a horizontal line at the tank's midpoint. Label the beginning of this line as Point A. Extend this line past the edges of the tank (figure 78).

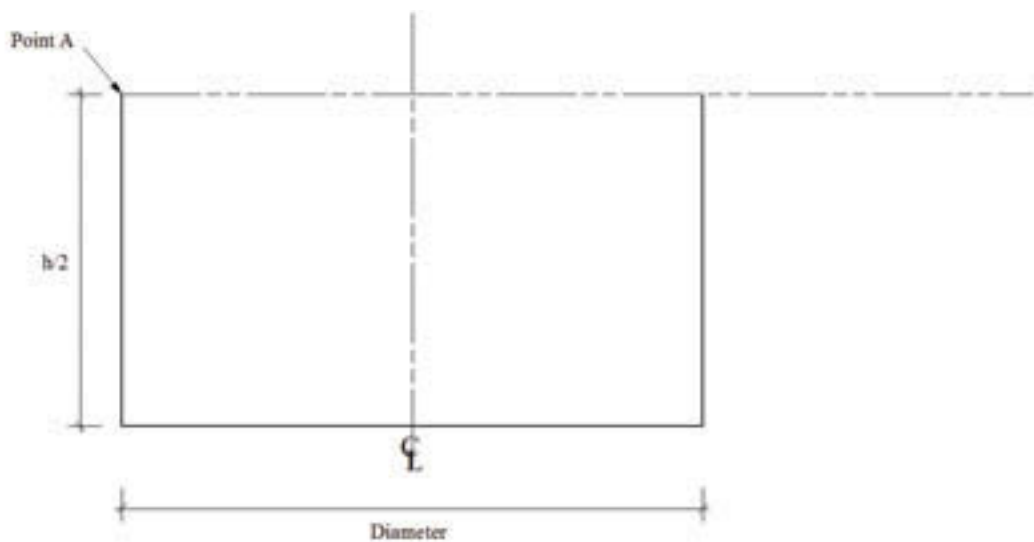

Fig. 78: Tank shape, bottom — Step 1

5. Draw a line with an angle of 20° from the lower left hand corner of the tank (Point B) and extend it until it crosses the line just drawn at the tank midpoint. Label the intersection of these two lines as Point C (figure 79).

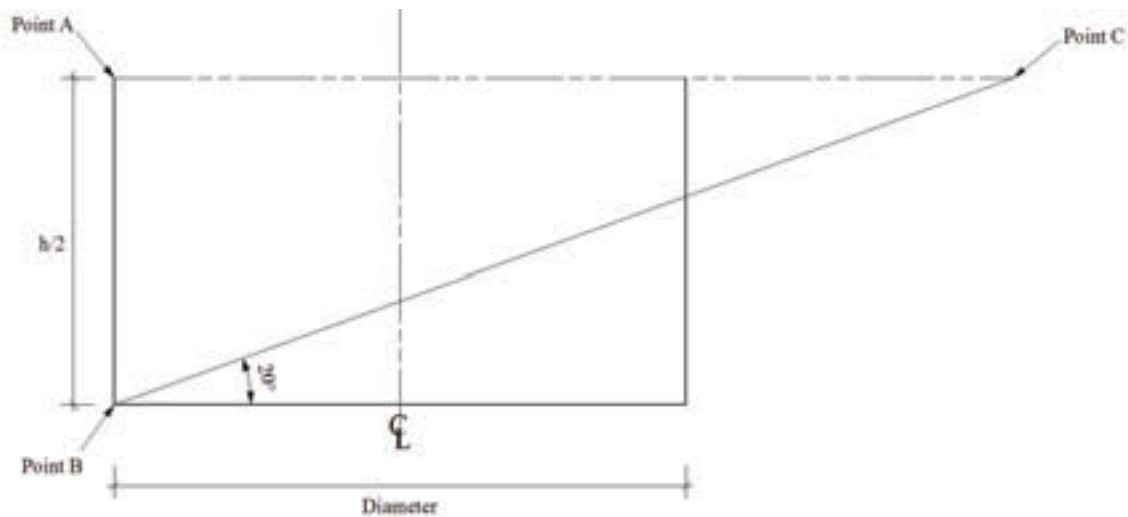

Fig. 79: Tank shape, bottom — Step 2

6. Line AC is the radius of the curve at the bottom of the tank. To find the shape, draw the arc from Point A to Point B (figure 80). The 20-degree limit is to assure that the mortar will not fall off while it is being applied by trowel on this section of the form.

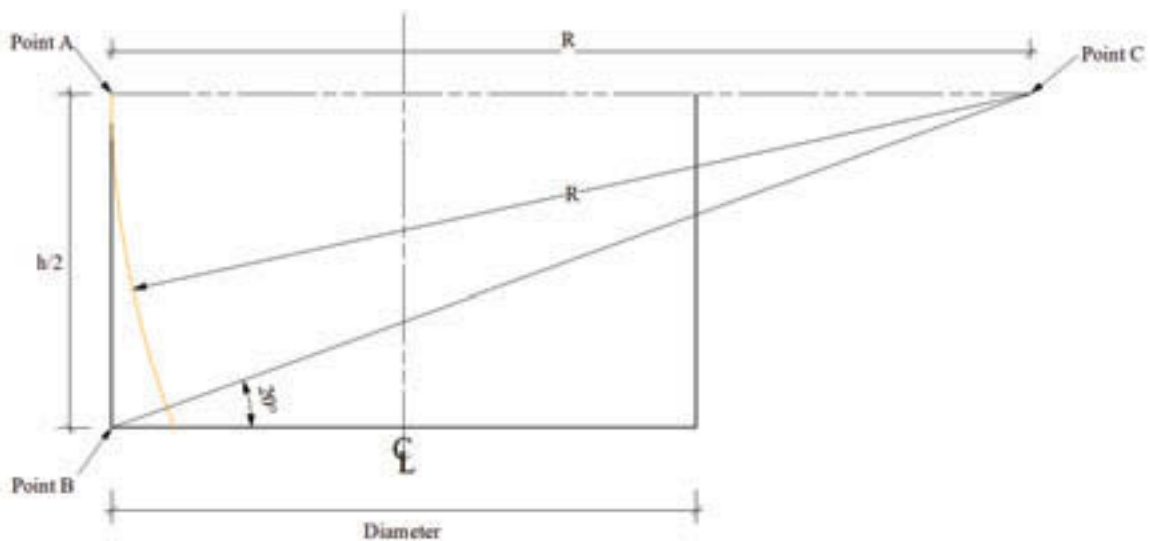

Fig. 80: Tank shape, bottom — Step 3

7. Combine the calculations for the top and bottom to get the complete shape of the tank (figure 81). This is also the shape and size of the vertical steel bar pieces needed to build a form.

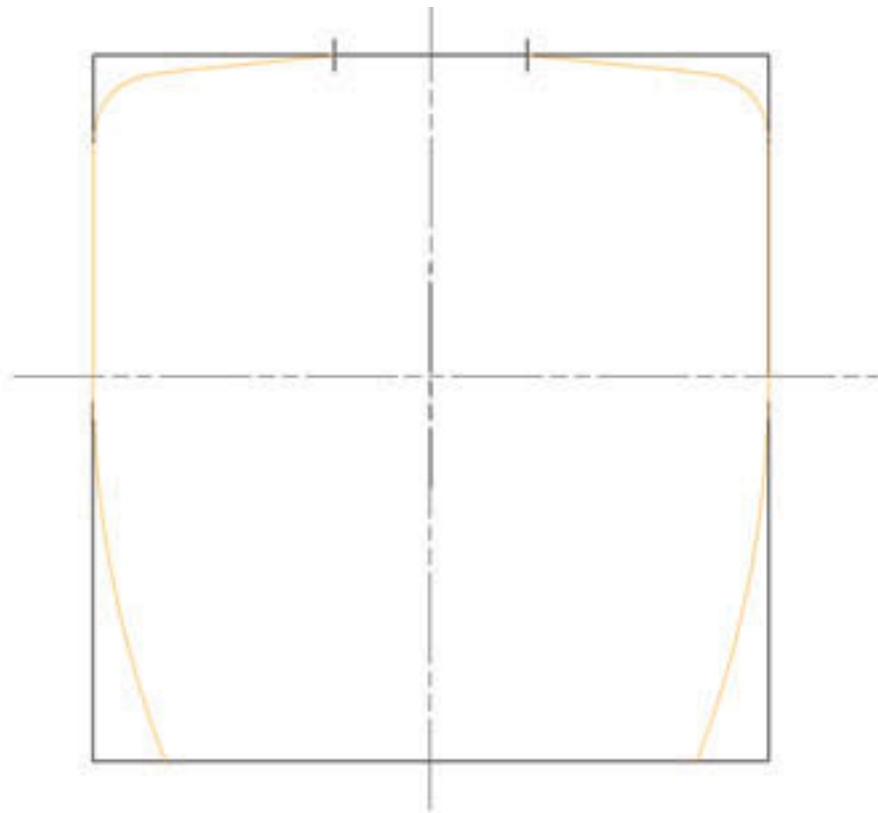

Fig. 81: Final tank shape

Appendix C - Calculating Horizontal Wire Spacing

Horizontal wire wrapping provides enough strength to support the entire tank. The vertical wrapping, as mentioned in Part A, Section V of the manual, is intended to create stability in cases of earthquakes or high winds.

To determine the horizontal wire spacing, two major components are taken into consideration:

- 1) The amount of support the wire wrapping can provide.
- 2) The force of the water acting along the interior tank wall.

In a tank or any object with a similar cylindrical shape, water pressure is not evenly distributed. Rather, the force of the water is higher towards the bottom of the tank and lower near the water's surface. The force acts at the center of gravity of the tank wall, a point located at an elevation equal to one-third of the tank height. This point is called a centroid. To compensate for the changing force and these centroids, the reinforcing horizontal wire wrappings must be spaced appropriately.

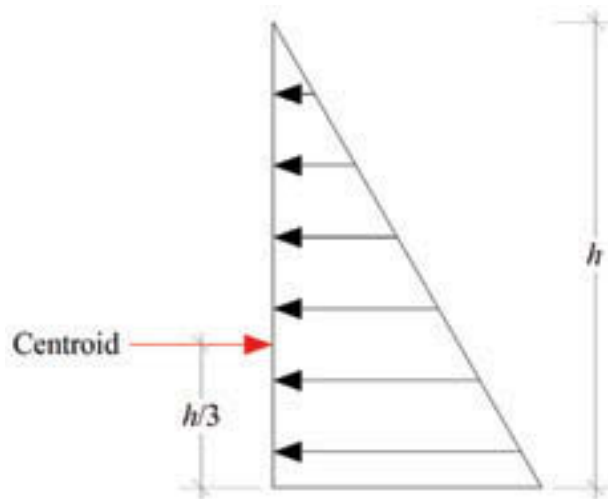

Fig. 82: The water pressure triangle

To determine horizontal wire spacing, it is necessary to know if the tank will be part of a piped or rainwater catchment system. It is also necessary to know the tank's volume, height, and waist diameter.

Step 1: Based on the location of centroids, the tank must be separated into sections. Each will have a height that is one-third of the unwrapped portion of the tank above it, resulting in sections that get smaller in height closer to the top of the tank.

Step 2: Between each section of the tank, there will be a "belt" section. The wire wrappings in this section should be spaced twice as closely as in the regular section below it. The purpose of the belted sections is to provide extra support at the centroids for each portion of the tank. The lowest belt section will be 20 cm in height while the remaining belts will each have a height of 10 cm.

Step 3: When the remaining unwrapped portion of the tank is less than 0.45 m, the horizontal wire wrapping can be completed by wrapping the remaining section with an evenly spaced series of wire wrapping equal in number to 11 times the tank diameter.

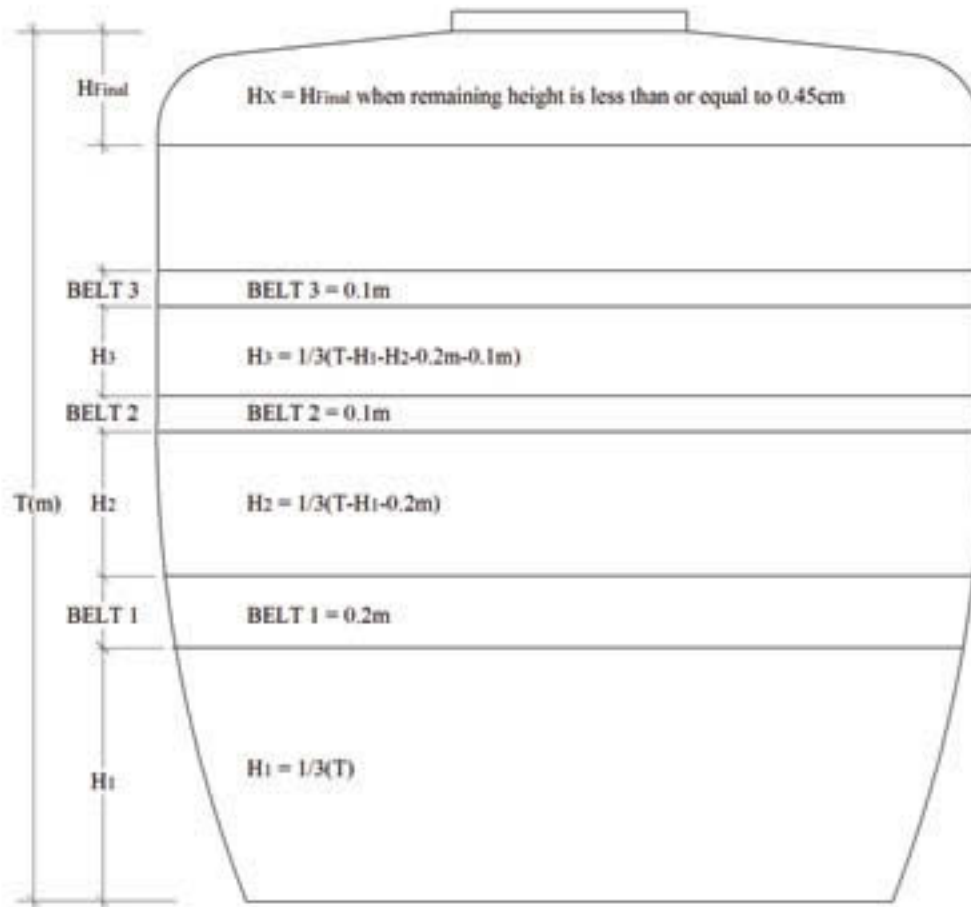

Fig. 83: Determining horizontal wire wrapping density

The example below demonstrates how to determine wire spacing for a tank 6 m^3 (6,000 L) in volume. The same process can be used for any size tank. Be careful when going through the calculations to keep the tank height and waist diameter in meters and not centimeters. Unit conversion has already been taken into account for all equations. Also, refer to figure 83 for a visual of how the wire spacing and belts are laid out along the tank vertical. If a computer is easily accessible, this manual's companion CD-ROM includes a spreadsheet which can calculate wire spacing and section height.

$$\text{Force (lbs)} = 9.81 \text{ kN/m}^2 \times \frac{1000 \text{ mm/m}}{4.448 \text{ kN/lb}} \times \left(\frac{T}{2}\right) \times (\phi) \times (h)$$

Simplified,

$$\text{Force (lbs)} = 1102.7 \times T \times \phi \times h$$

Where: T = total height (m) of remaining unwrapped portion of tank
 h_s = section height (m)
 ϕ = waist diameter (m)

Once the force for each section is calculated, use the following equation to determine the number of wire wrappings necessary for each section. The number of necessary horizontal wrappings varies depending on whether the system is piped or rainwater catchment.

Number of wire wrappings (N) needed in each section:

Piped System:

$$N = \frac{\text{Force}}{45.738}$$

Rainwater Catchment System:

$$N = \frac{(\text{Force} \times 0.5)}{45.738}$$

Note: Round the number of wire wrappings (N) up to the nearest integer. Also, for the final, top section, the number of necessary wire wrappings is simply equal to 11 times the waist diameter.

To determine the spacing, in millimeters, needed between wires for each section, use the following equation:

$$\text{Spacing (mm)} = \frac{h_s \times 1000 \text{m} / \text{m}}{N}$$

Where: h_s = section height (m)
 N = number of wires in the section

Note: Remember that for the “belt” sections, the spacing between wires is simply ½ that of the section below it

Example:

6 m³ tank — piped system
 $T = 2.1 \text{m}$
 $\phi = 2.0 \text{m}$

Section 1:

$$h_s = \frac{1}{3}T = \frac{1}{3} \times 2.1 = 0.7 \text{m}$$

$$\text{Force (lbs)} = 1102.7 \times T \times \phi \times h_s = 1102.7 \times 2.1 \times 2.0 \times 0.7 = 4153.1 \text{lbs}$$

$$N = \frac{4153.1 \text{lbs}}{45.738} = 90.8 = 91 \text{ wires}$$

$$\text{Spacing} = \frac{0.7 \text{m} \times 1000 \text{mm/m}}{91} = 7.7 \text{mm}$$

Belt 1:

$$h_s = 20 \text{ cm} = 0.2 \text{ m}$$

$$\text{Spacing} = \frac{7.7 \text{ mm}}{2} = 3.85 \text{ mm}$$

$$N = \frac{0.2 \text{ m} \times 1000 \text{ mm/m}}{14.6 \text{ mm}} = 13.7 \text{ wires} = 14 \text{ wires}$$

Section 2:

$$h_s = \frac{1}{3}(2.1 - 0.7 \text{ m} - 0.2 \text{ m}) = 0.40 \text{ m}$$

$$\begin{aligned} \text{Force (lbs)} &= 1102.7 \times T \times \phi \times h_s \\ &= 1102.7 \times (2.1 - (0.7 + 0.2)) \text{ m} \times 2.0 \text{ m} \times 0.40 \text{ m} = 1356.1 \text{ lbs} \end{aligned}$$

$$N = \frac{1356.1 \text{ lbs}}{45.738} = 29.6 \text{ wires} = 30 \text{ wires}$$

$$\text{Spacing} = \frac{0.40 \text{ m} \times 1000 \text{ mm/m}}{30} = 13.33 \text{ mm}$$

Belt 2:

$$h_s = 10 \text{ cm} = 0.1 \text{ m}$$

$$\text{Spacing} = \frac{13.3 \text{ mm}}{2} = 6.65 \text{ mm}$$

$$N = \frac{0.1 \text{ m} \times 1000 \text{ mm/m}}{6.65 \text{ mm}} = 15.04 \text{ wires} = 15 \text{ wires}$$

Section 3:

$$h_s = \frac{1}{3}(2.1 - (0.7 \text{ m} + 0.2 \text{ m} + 0.43 \text{ m} + 0.1 \text{ m})) = 0.223 \text{ m}$$

$$\begin{aligned} \text{Force (lbs)} &= 1102.7 \times T \times \phi \times h_s \\ &= 1102.7 \times (2.1 - (0.7 + 0.2 + 0.4 + 0.1)) \text{ m} \times 2.0 \text{ m} \times 0.40 \text{ m} = 461.45 \text{ lbs} \end{aligned}$$

$$N = \frac{461.45\text{lbs}}{45.738} = 10.09 \text{ wires} = 10 \text{ wires}$$

$$\text{Spacing} = \frac{0.223\text{m} \times 1000\text{mm/m}}{10} = 22.3\text{mm}$$

Belt 3:

$$H = 10\text{cm} = 0.1\text{m}$$

$$\text{Spacing} = \frac{22.3\text{mm}}{2} = 11.15 \text{ mm}$$

$$N = \frac{0.1\text{m} \times 1000 \text{ mm/m}}{11.15\text{mm}} = 8.97 \text{ wires} = 9 \text{ wires}$$

Section 4:

$$h_s = \frac{1}{3}(2.1 - (0.7\text{m} + 0.2\text{m} + 0.43\text{m} + 0.1\text{m} + 0.223\text{m} + 0.1\text{m})) = 0.115\text{m}$$

*** Remaining height is less than 0.45 meters $\{(2.1 - (0.7 + 0.2 + 0.43 + 0.1 + 0.223 + 0.1)) = 0.347\text{m}\}$. Therefore, this will be the last section for wire wrapping.*

$$N = \frac{11\text{wires}}{\text{m}} \times \phi = 11 \times 2.0\text{m} = 22$$

$$\text{Spacing} = \frac{0.347\text{m} \times 1000\text{mm/m}}{22} = 15.77 \text{ mm}$$

This last section continues until the wire begins to slip due to the curve of the tank roof. At this point, extra wrappings are needed to counteract thermal expansion of the roof. To determine the number of wire wrappings needed use the following equation⁴:

$$N_{extra} = 4.452 \times \phi$$

Where,

N_{extra} = number of extra wire wrappings

ϕ = Tank Diameter

and, wire wrapping uses #18 wire ($\phi_{wire} = 1.4 \text{ mm}$)

⁴ This equation is based on the quantity of reinforcement which practical experience has shown will effectively address cracking due to thermal expansion of the roof.

Appendix D - Sample Designs

This appendix provides a series of sample designs for wire reinforced ferrocement jars in a range of sizes from 3,000 L to 20,000 L. These designs are based on the calculations of the Form and Tank Materials Estimator, a spreadsheet included on this manual's companion CD-ROM. While considerable effort has been made to present the best possible estimates, a number of factors which may influence material quantities and costs should be recognized.

1. Most importantly, these estimates assume that tanks will be constructed by workers trained in ferrocement construction. Without such training, the layers of mortar are typically plastered far more thickly than necessary. If untrained masons are used the thickness of the plastered layers must be monitored rigorously or more cement, sand and waterproofing compound should be purchased.
2. The use of unskilled labor may also affect the length of construction and increase labor costs.
3. These estimates assume that good quality, non-calcareous sand is used. If lower quality sand will be used, material estimates should be recalculated using the spreadsheet and selecting the appropriate option in the "Type of sand to be used" input box.
4. Cement mortar should be mixed on clean level surfaces. Mixing on other, less desirable surfaces (e.g. surface soil) can lead to increased wastage and compromise the strength of the mortar.
5. Estimates for form costs and materials assumes that extra rebar will not be used for vertical support but that wood or bamboo poles are used instead. See Part A, Section III, The Form, Constructing the Form, Step 6.

3,000 Liter Wire-Reinforced Jar

1. Tank Shape

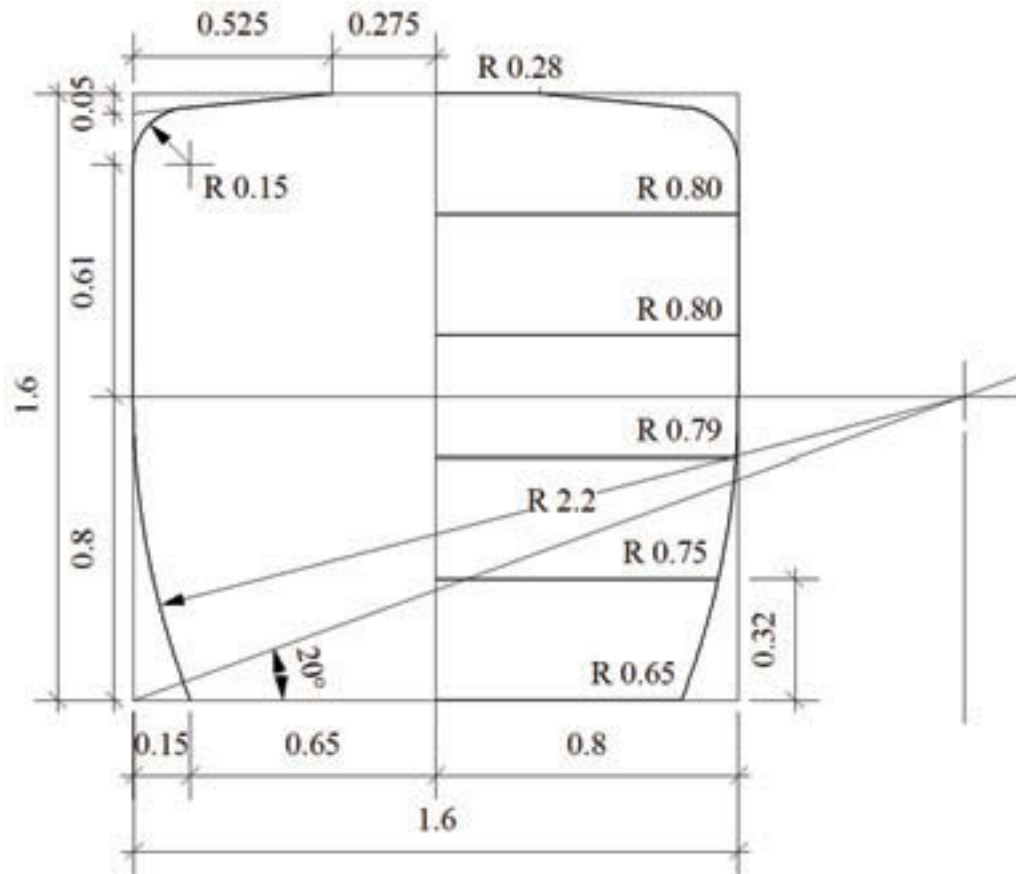

2. Estimate of Form Materials

Horizontal Pieces

needed = 6
length of horizontal pieces

- 1 @ C = 1.72 m
- 2 @ C = 5.03 m
- 1 @ C = 4.96 m
- 1 @ C = 4.71 m
- 1 @ C = 4.08 m

Vertical Pieces

needed = 35
length of vertical pieces = 2.03 m
total steel rebar needed (6 m x 8 mm) = 17 pieces
1/2" wire mesh needed = 13 m²

3. Horizontal Wire Spacing

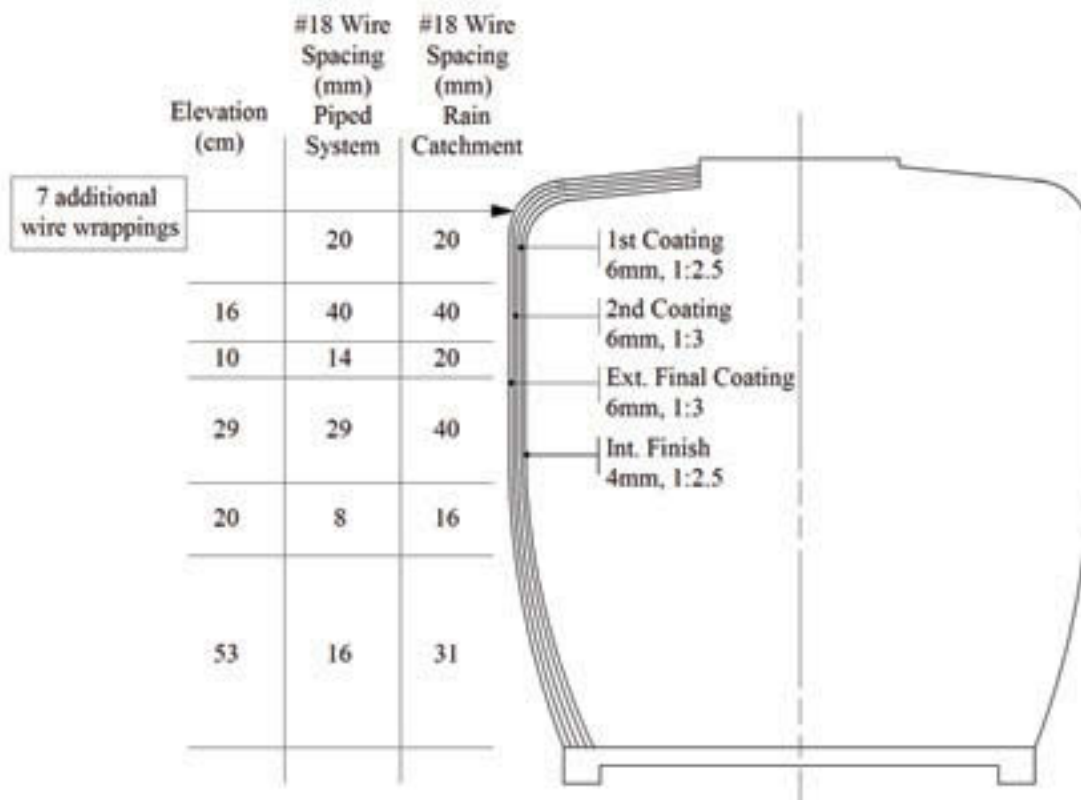

4. Tank Labor and Material Estimate

Material	Piped System	Rainwater Catchment
Portland cement (40 kg sack)	5.66	5.66
Sand (cubic meter)	0.48	0.48
Gravel (cubic meter)	0.15	0.15
Sahara waterproofing compound (bag)	5.66	5.66
#18 tie wire (kg)	6.8	4.4
8 mm steel rebar (6 m)	1	1
2" diameter x 4" GI nipple with end cap	1	1
1" x 3" GI nipple with plug	1	1
2" diameter x 4" GI nipple	2	2
2" gate valve	1	1
3 mm screen (m)	1	1
GI sheet (0.8 x 2 m)	1	1
Unskilled labor (days)	3	3
Skilled labor (days)	3	3

5,000 Liter Wire-Reinforced Jar

1. Tank Shape

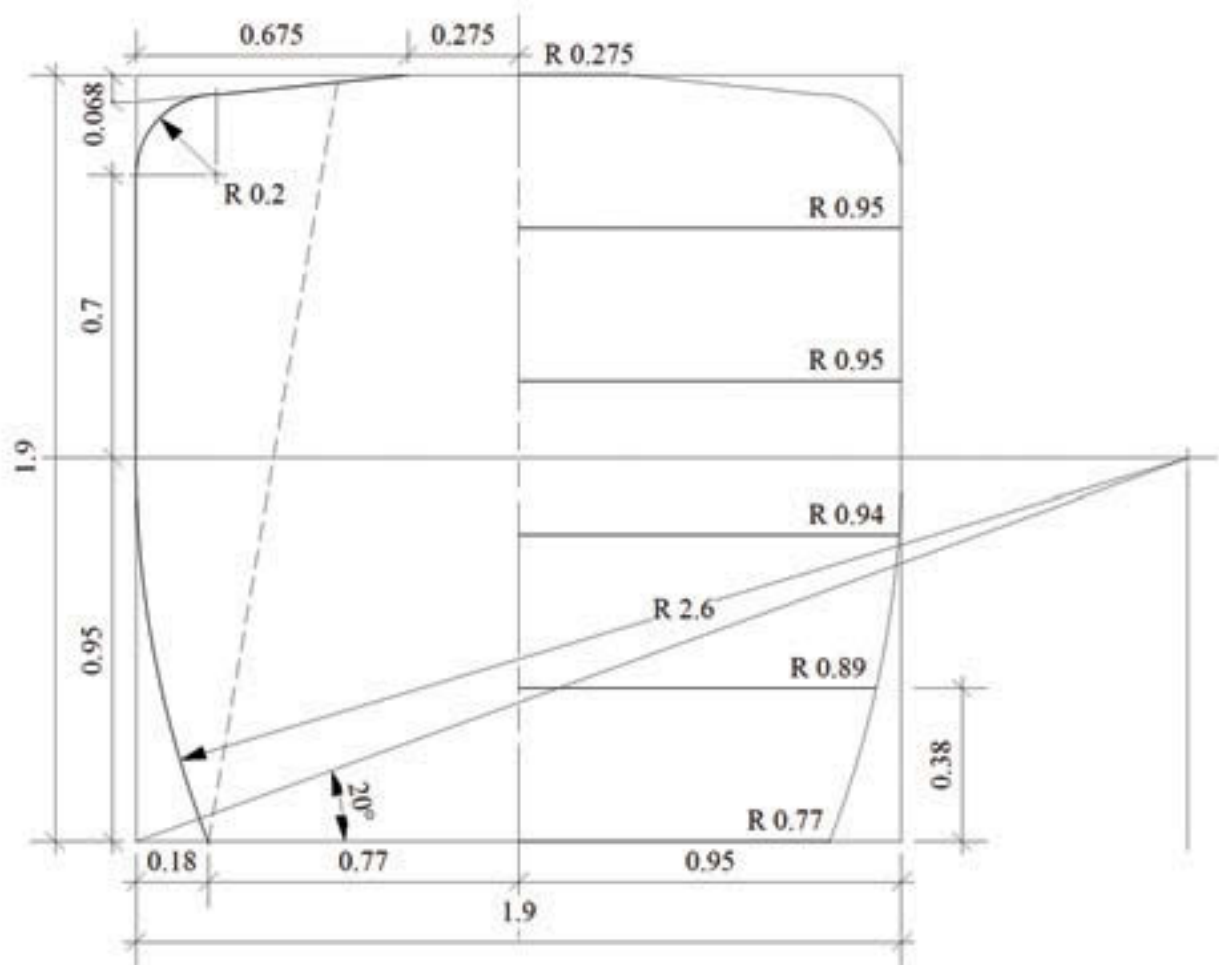

2. Estimate of Form Materials

Horizontal Pieces

needed = 6
length of horizontal pieces

- 1 @ C = 1.72 m
- 2 @ C = 5.96 m
- 1 @ C = 5.90 m
- 1 @ C = 5.59 m
- 1 @ C = 4.84 m

Vertical Pieces

needed = 42
length of vertical pieces = 2.47 m

total iron rebar needed (6 m x 8 mm) = 25 pieces

1/2" wire mesh needed = 18 m²

3. Horizontal Wire Spacing

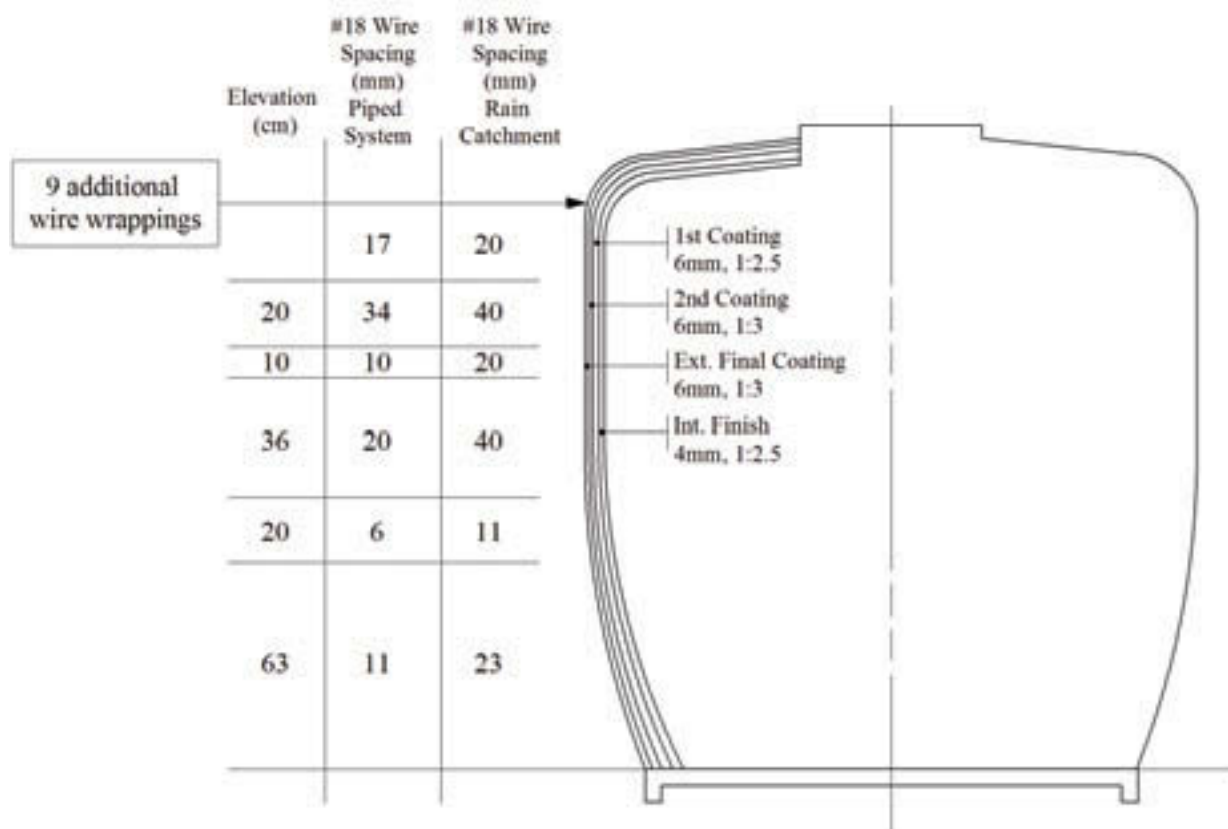

4. Tank Labor and Material Estimate

Material	Piped System	Rainwater Catchment
Portland cement (40 kg sack)	8	8
Sand (cubic meter)	0.68	0.68
Gravel (cubic meter)	0.2	0.2
Sahara waterproofing compound (bag)	8	8
#18 tie wire (kg)	12.4	7.4
8 mm steel rebar (6 m)	1	1
2" diameter x 4" GI nipple with end cap	1	1
1" x 3" GI nipple with plug	1	1
2" diameter x 4" GI nipple	2	2
2" gate valve	1	1
3 mm screen (m)	1	1
GI sheet (0.8 x 2 m)	1	1
Unskilled labor (days)	6	6
Skilled labor (days)	3	3

7,500 Liter Wire-Reinforced Jar

1. Tank Shape

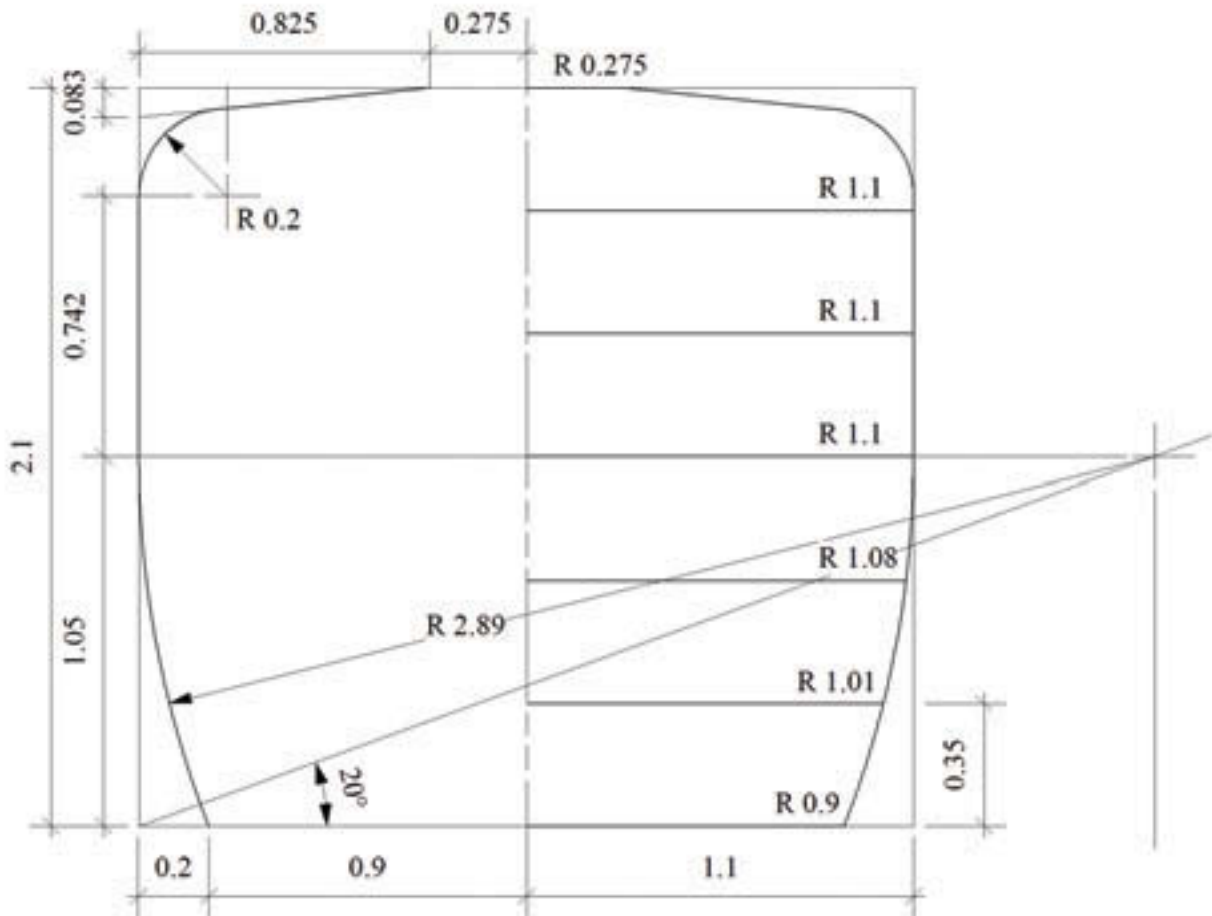

2. Estimate of Form Materials

Horizontal Pieces

needed = 7
length of horizontal pieces

1 @ C = 1.72 m
3 @ C = 6.91 m
1 @ C = 6.75 m
1 @ C = 6.35 m
1 @ C = 5.65 m

Vertical Pieces

needed = 49
length of vertical pieces = 2.81 m

total iron rebar needed (6 m x 8 mm) = 33 pieces

1/2" wire mesh needed = 23 m²

3. Horizontal Wire Spacing

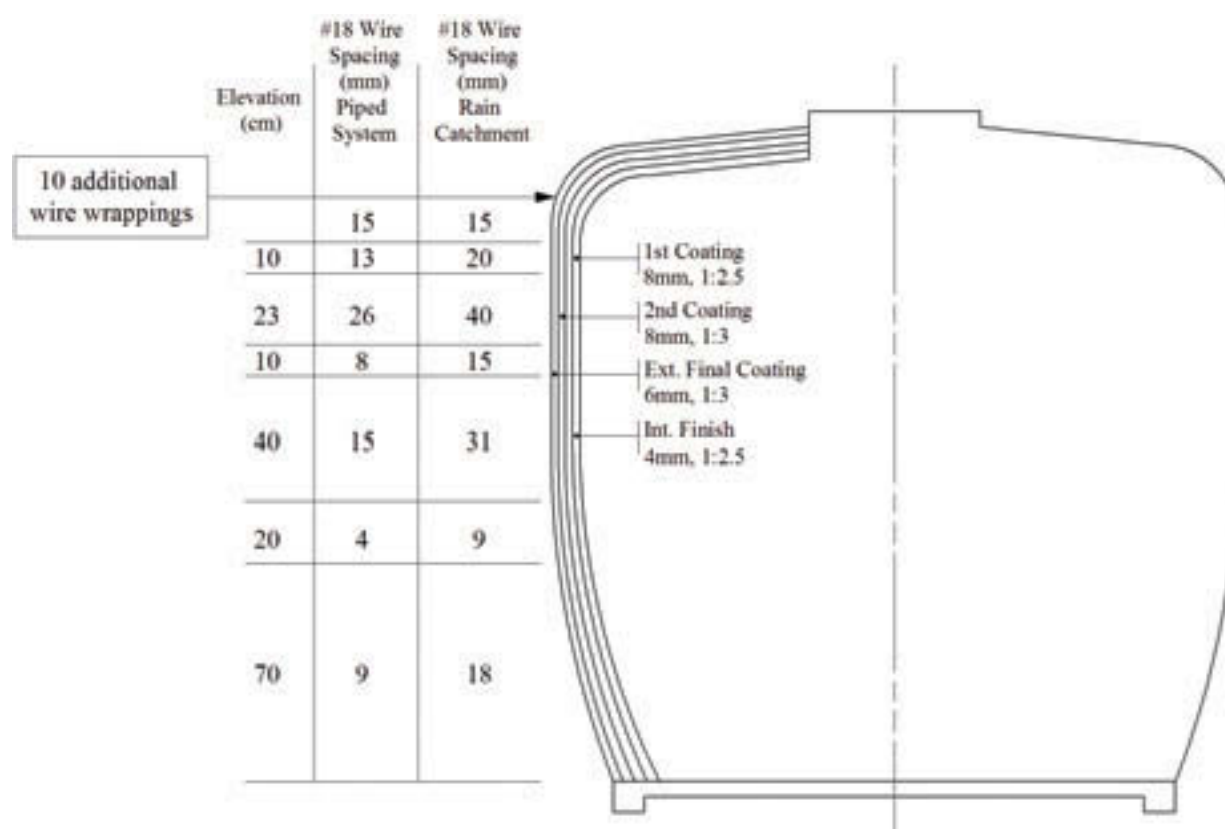

4. Tank Labor and Material Estimate

Material	Piped System	Rainwater Catchment
Portland cement (40 kg sack)	10.7	10.7
Sand (cubic meter)	0.91	0.91
Gravel (cubic meter)	0.3	0.3
Sahara waterproofing compound (bag)	10.7	10.7
#18 tie wire (kg)	19.4	11.8
8 mm steel rebar (6 m)	3.4	3.4
2" diameter x 4" GI nipple with end cap	1	1
1" x 3" GI nipple with plug	1	1
2" diameter x 4" GI nipple	2	2
2" gate valve	1	1
3 mm screen (m)	1	1
GI sheet (0.8 x 2 m)	1	1
Unskilled labor (days)	8	8
Skilled labor (days)	4	4

10,000 Liter Wire-Reinforced Jar

1. Tank Shape

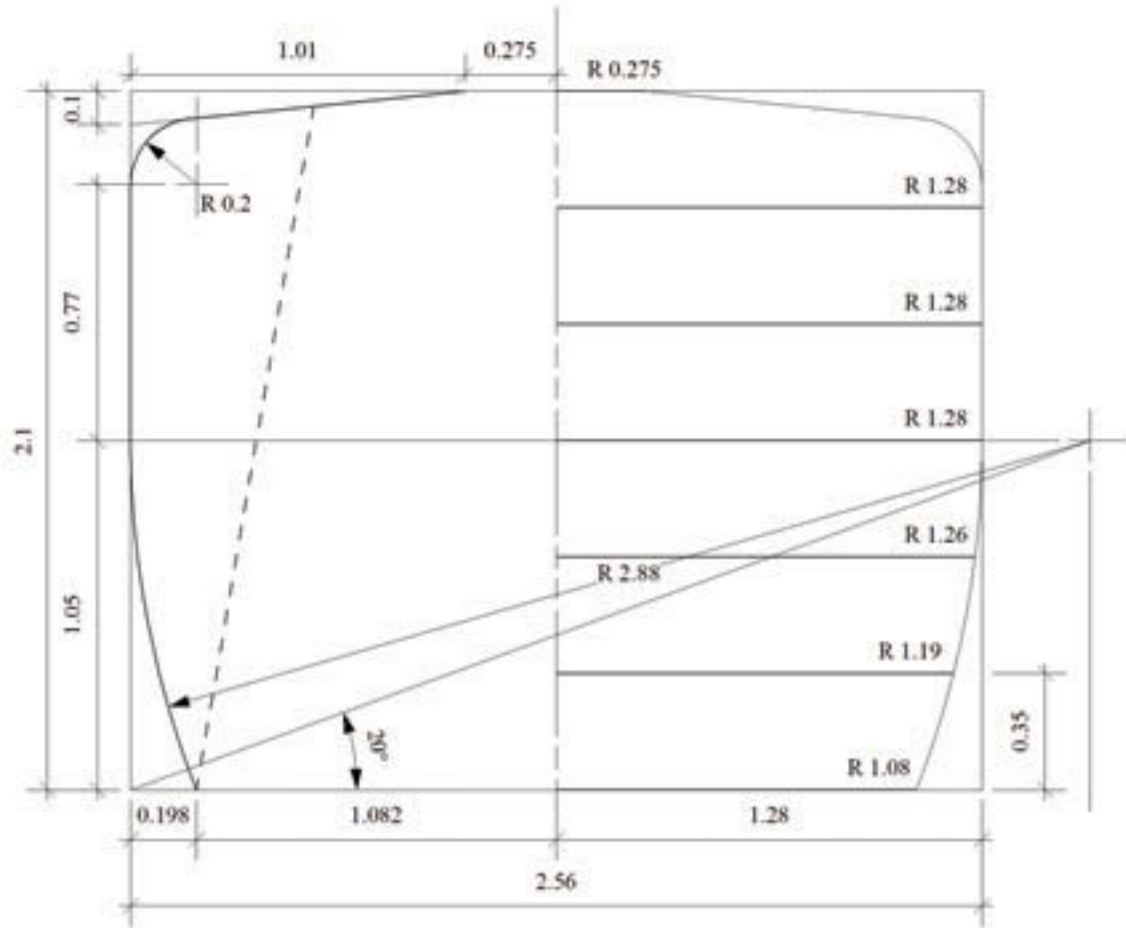

2. Estimate of Form Materials

Horizontal Pieces

needed = 7
length of horizontal pieces

- 1 @ C = 1.72 m
- 3 @ C = 8.04 m
- 1 @ C = 7.91 m
- 1 @ C = 7.47 m
- 1 @ C = 6.78 m

Vertical Pieces

needed = 56
length of vertical pieces = 2.94 m

total iron rebar needed (6 m x 8 mm) = 38 pieces

1/2" wire mesh needed = 27 m²

3. Horizontal Wire Spacing

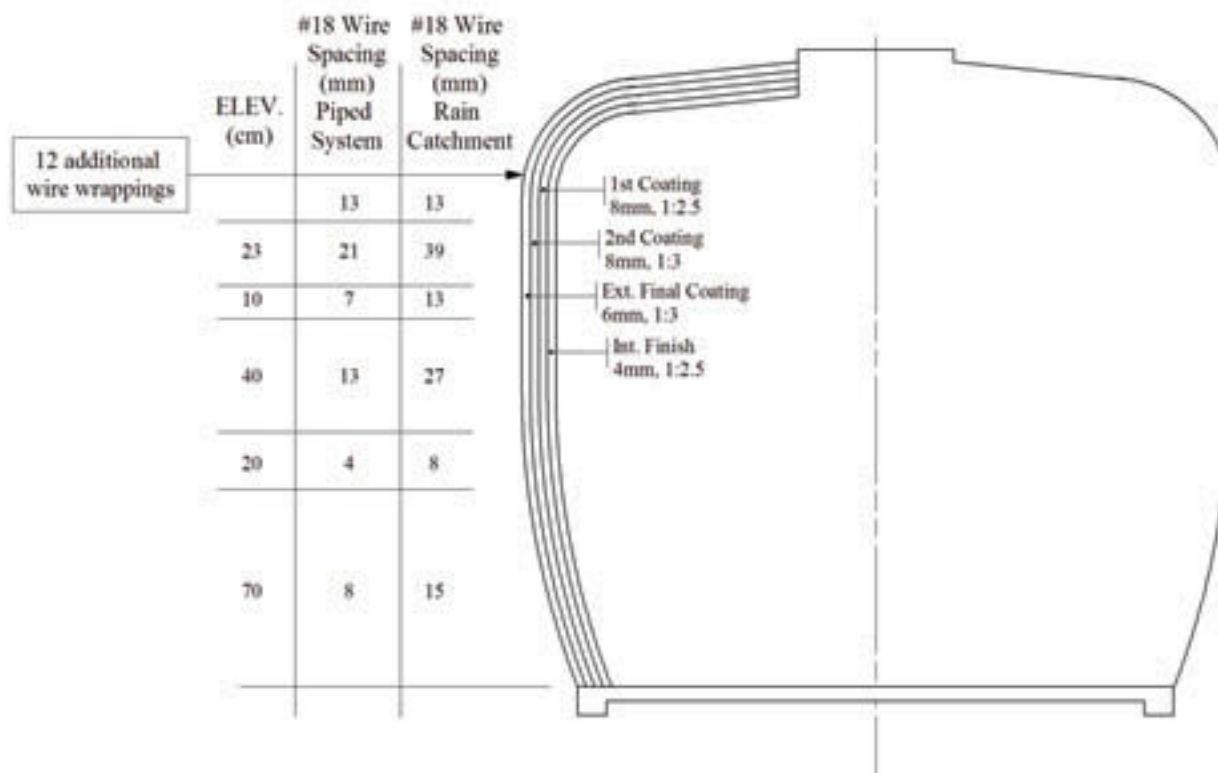

4. Tank Labor and Material Estimate

Materials	Piped System	Rainwater Catchment
Portland cement (40 kg sack)	13	13
Sand (cubic meter)	1.1	1.1
Gravel (cubic meter)	0.4	0.4
Sahara waterproofing compound (bag)	13	13
#18 tie wire (kg)	26	16
8 mm steel rebar (6 m)	4	4
2" diameter x 4" GI nipple with end cap	1	1
1" x 3" GI nipple with plug	1	1
2" diameter x 4" GI nipple	2	2
2" gate valve	1	1
3 mm screen (m)	1	1
GI sheet (0.8 x 2 m)	1	1
Unskilled labor (days)	10	10
Skilled labor (days)	5	5

20,000 Liter Wire-Reinforced Jar

1. Tank Shape

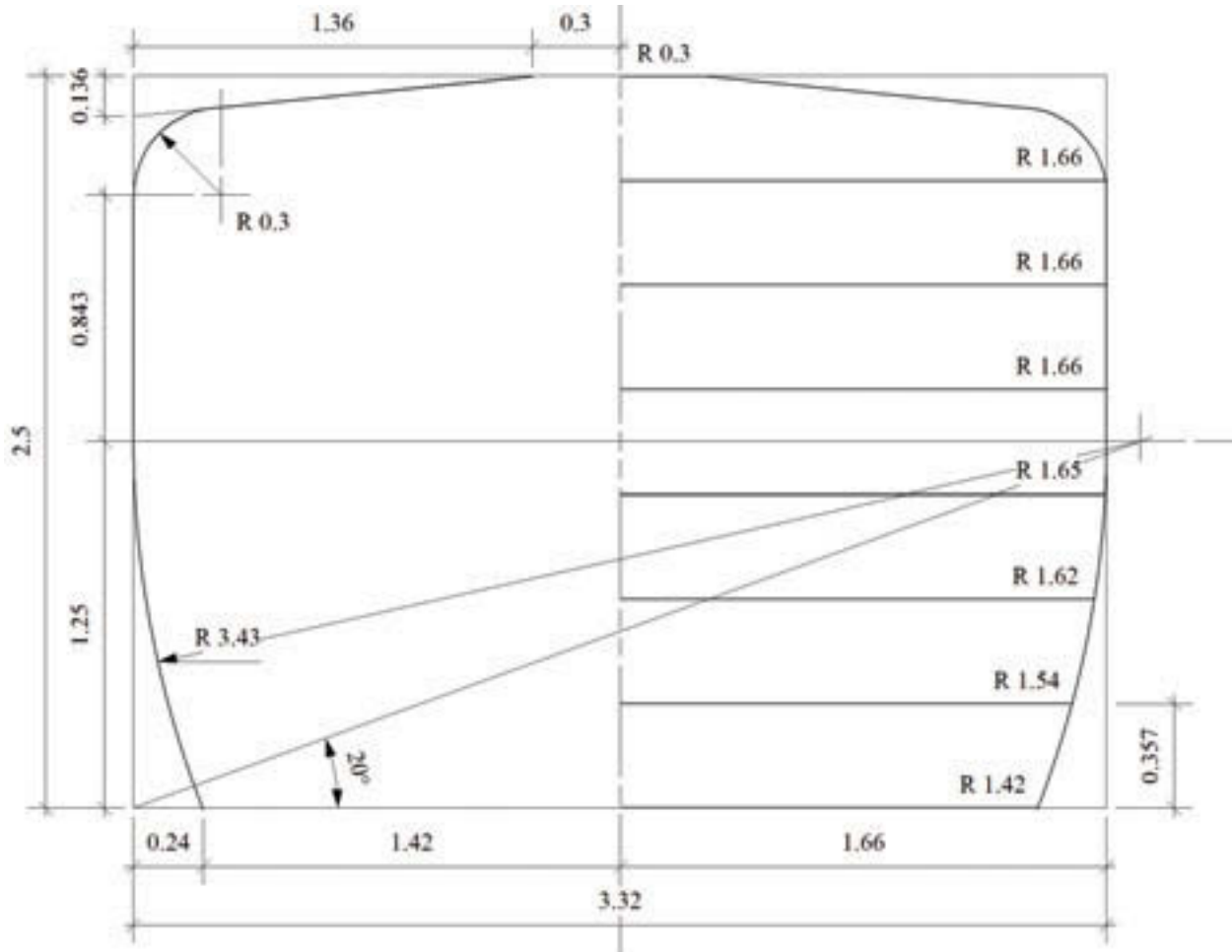

2. Estimate of Form Materials

Horizontal Pieces

needed = 8
length of horizontal pieces

- 1 @ C = 1.88 m
- 3 @ C = 10.42 m
- 1 @ C = 10.36 m
- 1 @ C = 10.17 m
- 1 @ C = 9.67 m
- 1 @ C = 8.92 m

Vertical Pieces

needed = 73
length of vertical pieces = 3.68 m

total iron rebar needed (6 m x 8 mm) = 62 pieces

1/2" wire mesh needed = 42 m²

3. Horizontal Wire Spacing

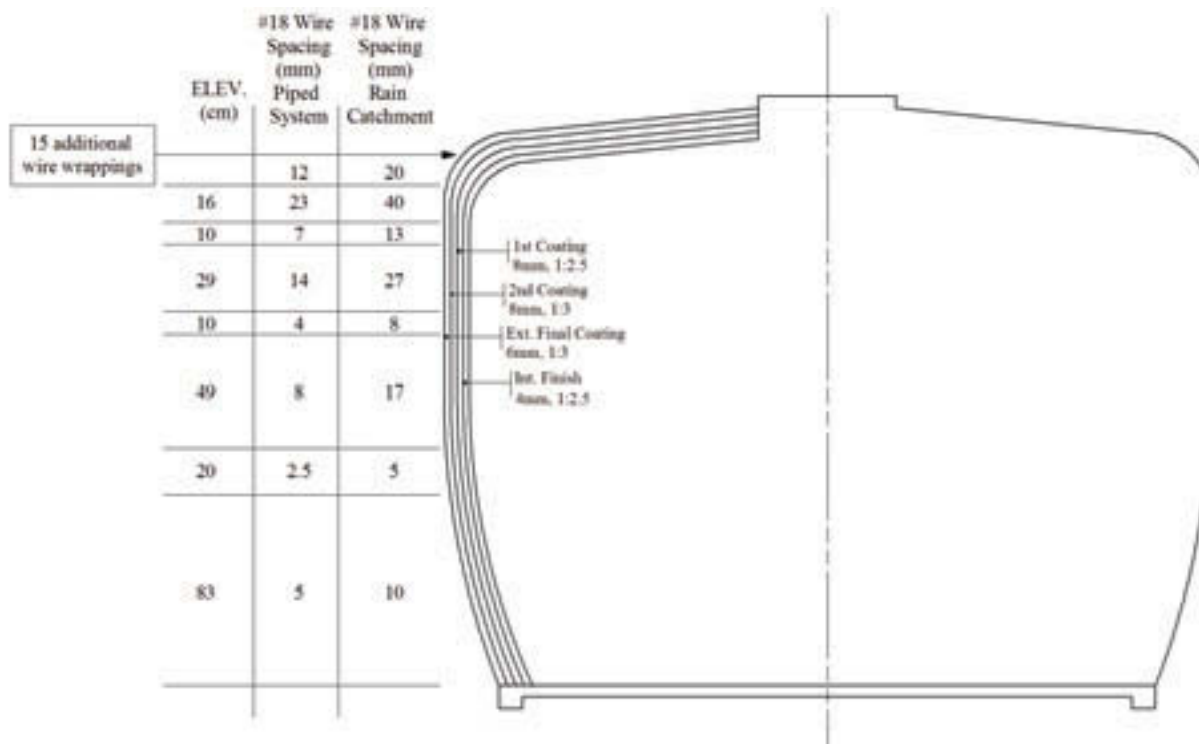

4. Tank Labor and Material Estimate

Material	Piped System	Rainwater Catchment
Portland cement (40 kg sack)	21.5	21.5
Sand (cubic meter)	1.85	1.85
Gravel (cubic meter)	.75	.75
Sahara waterproofing compound (bag)	21.5	21.5
#18 tie wire (kg)	54	31
8 mm steel rebar (6 m)	5.5	5.5
2" diameter x 4" GI nipple with end cap	1	1
1" x 3" GI nipple with plug	1	1
2" diameter x 4" GI nipple	2	2
2" gate valve	1	1
3 mm screen (m)	1	1
GI sheet (0.8 x 2 m)	1	1
Unskilled labor (days)	20	20
Skilled labor (days)	5	5

Appendix E - Drawing Water Directly from the Tank

The general construction instructions in this manual place the tank outlet 10 cm above the tank base (figure 28). This positioning is ideal when the tank is part of a piped system where one pipeline brings water from the source to the tank and a second pipeline carries the water from the tank to individual or communal faucets. However, in other cases the tank is the end point of the system, as in household rainwater catchment systems. In these situations, water is drawn directly from the tank, a task that is difficult when the outlet is placed near the base. Therefore, the tank design must be modified.

A Raised Foundation

One option is to construct the tank on a raised foundation. Lifting the entire tank allows one to fill buckets easily without moving the outlet. The foundation is constructed by filling a ferrocement ring with compacted rubble, which is then covered by a thin layer of poured concrete that incorporates the tank base (figure 84).

The first step is to construct the ferrocement ring. The ring should be 70 cm high and have a diameter slightly larger than the tank base (a good benchmark is waist diameter + 25 cm). Build a form of the proper size. If only one raised foundation is being built, use wood and GI sheet for this form. However, if multiple foundations will be constructed, it may be more cost-efficient to build a more durable form from steel bar and wire mesh that is covered with papier mâché.

Building a Raised Foundation

1. When the form is complete, place it exactly where the tank will be located. Otherwise, the ferrocement ring will be heavy and difficult to move later.
2. Apply a 6 mm layer of cement mortar (1:3 cement:sand) to the outside of the form. When this layer has hardened, wrap the ring with #18 tie wire every 1 cm. Once the wire wrapping is complete, plaster the ring with a second layer of cement mortar 8 mm thick. Make sure that all exposed wire is covered, and let the ring cure overnight.
3. Remove the form and plaster a final layer of mortar onto the inside of the ring. The total thickness of the ferrocement ring should be 22–25 mm. Let the ring cure overnight.
4. A portion of the ring should sit below ground level. Carefully excavate 20 cm inside the ring and below the ring walls so that the ring slowly drops into the proper position. Then fill the ring with compacted rubble to within 5 cm of the top.
5. Rather than attaching the outlet and cleanout to the side of the tank, integrate them into the base by: 1) laying the pipes in the proper position (figure 84), 2) adding the base reinforcement as detailed in Part I (figures 23a-d, 24) and 3) pouring the base. Be sure that no cement gets into the pipes by covering their ends during the cement-pouring process or stuffing the ends with newspapers or cement bags.

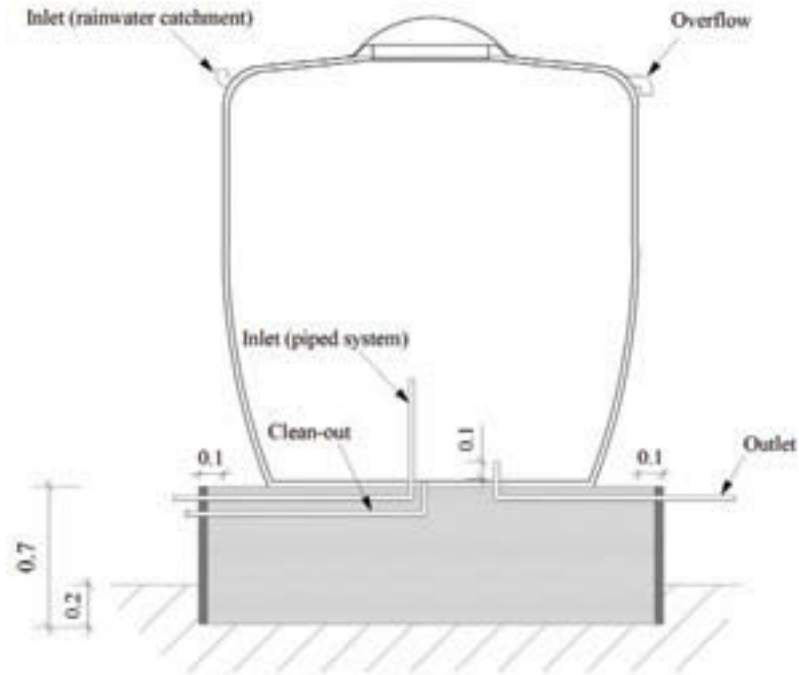

Fig. 84: Building a raised foundation

Other Options

Digging a Sump

Probably the simplest way to allow people to draw water from the tank is to dig a sump below the outlet. A sump is a hole, deep enough and large enough to accommodate a bucket, that is dug into the ground adjacent to the tank (figure 85). The hole can be lined with a small ferrocement ring to prevent erosion. Line the bottom with gravel to facilitate drainage.



Fig. 85: Sump hole

Raising the Outlet

Raise the outlet to 45 cm above the base. To ensure adequate supply, one could build a tank slightly larger than needed, increasing the tank's height in relation to its width (keeping in mind the height:width ratio mentioned earlier). During water shortages, beneficiaries could then access the water at the bottom of the tank via the cleanout valve.

Appendix F - CD-ROM Notes

Included with this manual are two spreadsheets which can be used to determine tank size, material costs, and building requirements.

Workbook 1: Tank volume estimator

- o Rain Catchment: This spreadsheet uses local rainfall data and household water demand to estimate needed water storage capacity. Output also shows which months have excess water due to heavy rain. (Developed by FloTrue International)
- o EcoTank: This spreadsheet determines the reservoir volume for a gravity flow piped system based on given population size, growth rate, source flow, and daily per capita consumption. By analyzing three different daily supply and demand schedules, EcoTank suggests needed storage volume.
- o EcoRain: This spreadsheet helps the user determine the most economical rainwater cistern size based on a cost-benefit comparison of three inputted tank sizes. This is determined by inputting the roof catchment area, daily consumption data, distances to water sources, material costs, and desired tank volume.

Workbook 2: Form and Tank material estimator

- o Input: Desired tank volume (determined by using Workbook 1: Tank Volume Estimator), height and local material prices are entered into the input page. The form materials, tank materials, and horizontal wire spacing are automatically computed and displayed on the other pages of this workbook.
- o Form Materials Estimator: Calculates the quantity of materials needed for form construction, given tank volume, height, and local prices.
- o Tank Material Estimator: Using local prices and tank volume, this spreadsheet estimates the quantity of materials needed to construct the wire-reinforced ferrocement jar.

Spreadsheet comments and limitations

- The estimates produced do not include the materials for the reusable form (see form materials estimator worksheet for cost).
 - As part of estimating needed materials, the spreadsheet computes the spacing for the tank's horizontal wire reinforcement. This information can also easily be viewed on a separate sheet in this workbook.
 - Actual materials consumed during construction will vary due to materials' quality and worker skill.
- o Horizontal Wire Spacing: This worksheet uses the tank height and waist diameter to determine the spacing for horizontal wiring that wraps around the tank.

Appendix G - Further Resources

FERROCEMENT

Ariyananda, T., *Rainwater Harvesting for Domestic Use in Sri Lanka*. 25th WEDC Conference: Addis Ababa, 1999.

Connelly, Garrett. Ferrocement Tank Construction. <http://ferrocement.com>

Department of Technical Cooperation for Development. Water Resource Assessment and Planning in Pacific Islands: Ferrocement Rainwater Tanks. UNDP, 1989.

Derucher, K., A.S. Ezeldin, and G. Korfiatis. Materials for Civil and Highway Engineers. 4th ed. New Jersey: Prentice Hall, 1998.

Gaston, John P. *Construction of Ferrocement Tanks*. EWF.

Hasse, Rolf. Rainwater Reservoirs: Above ground structures for roof catchment. GATE/GZT. 1989.

How to Build a 5m³ Pumpkin Shaped Ferro-cement Rain Water Tank. E-mail, T. Ariyanada July 20, 2004.

Mullins, Dan. How to Build Ferrocement Tanks. Swaziland: Ministry of Education, 1988.

Naman, Antoine E., Ferrocement & Laminated Cementitious Composites. Ann Arbor: Techno Press 3000, 2000.

Rees, Dai and Vince Whitehead. *Ferro-cement Jar: Instructions for Manufacture*. Development Technology Unit, University of Waewick, 2000.

Sharma P.C. and V.S. Gopalaratnam. Ferrocement Water Tank. Bangkok: International Ferrocement Information Center, Asian Institute of Technology, 1980.

Turner, Stephan. "Design of Rainwater Storage Tanks for Use in Developing Countries." Diss. University of Warwick, 2000.

Watt, S.B. Ferrocement Water Tanks and Their Construction. London: Intermediate Technology Publications, Inc., 1978.

Watt, S.B. Septic Tanks and Aquaprivies from Ferrocement. London: Intermediate Technology Publications, Inc., 1984.

WATER SYSTEM DESIGN

Gould, John and Erik Nissen-Petersen. Rainwater Catchment Systems for Domestic Supply: Design, Construction and Implementation. London: Intermediate Technology Publications, Inc., 1999.

IRC International Water and Sanitation Centre. *Handpumps: Issues and concepts in rural water supply programs*. IRC, 1996.

IRC International Water and Sanitation Centre. *Small Community Water Supplies: Technology of Small Supply Systems in Developing Countries, 2nd ed.* IRC, 2002.

Jordan, Thomas. A Handbook of Gravity-flow Water Systems. London: Intermediate Technology Publications, Inc., 1984.

NOTES



**209 W. Fayette Street
Baltimore, Maryland 21201
USA**

www.crs.org